

PLAINTIFF'S EXHIBIT

---

NSC-142

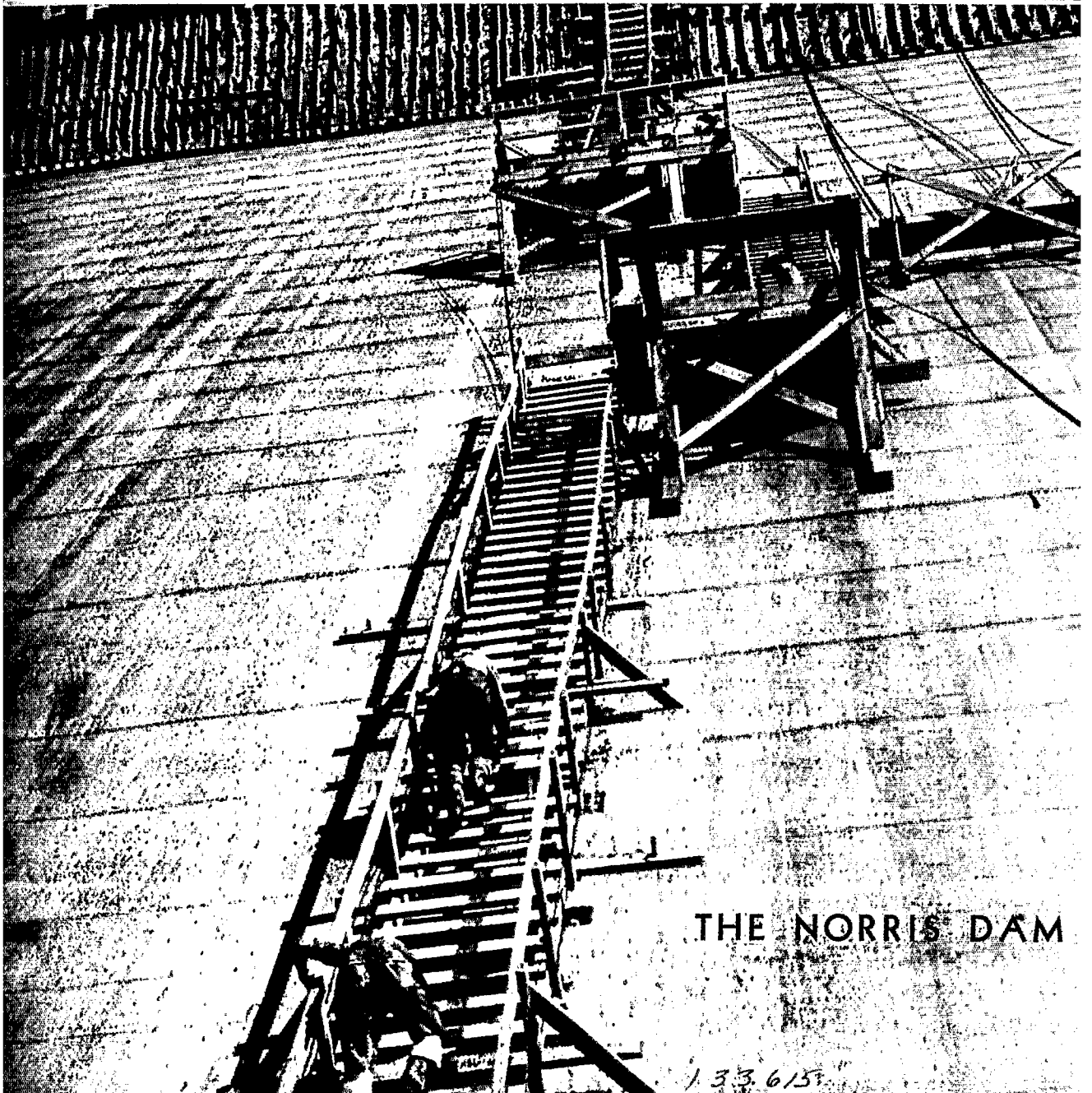

THE NORRIS DAM

133615

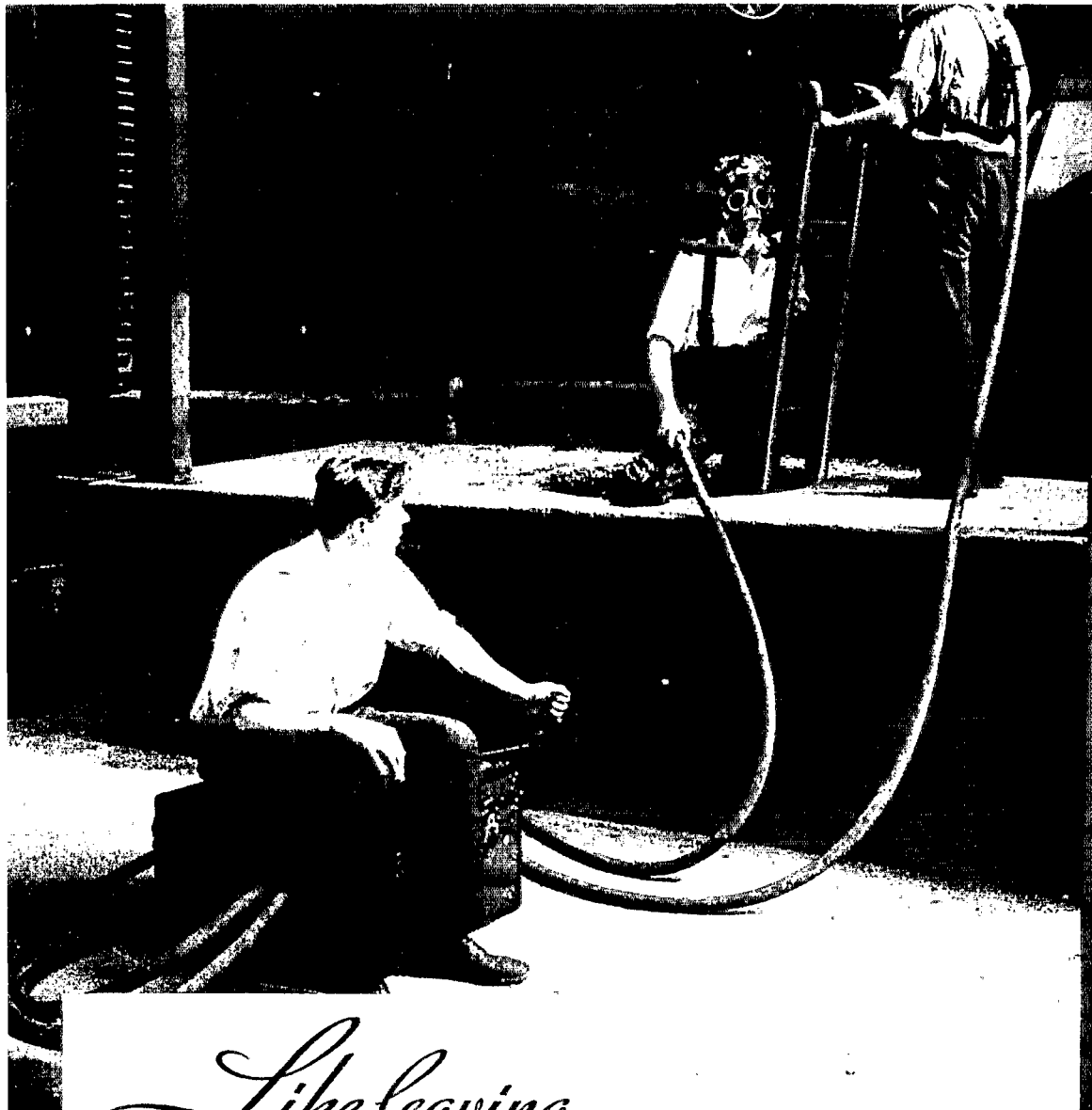

The New  
approved  
**2-WAY**  
**OUTFIT**  
in use

*Like leaving  
your lungs outside!*

**THE SAFETY APPLIANCE COMPANY**

*New WILLSON GOGGLE. Style RR50, with patented frontal ventilation and shock absorbing spacer ring*



# *WILLSON PRODUCTS*

READING

INCORPORATED

PENNA.

The NATIONAL SAFETY NEWS is published monthly by the National Safety Council, 1300 Webster Drive, Chicago, Ill. Yearly subscription Price \$4.00. Volume 32, Number 5. Entered as second class matter June 1, 1921, at the Postoffice at Chicago, Illinois, under the Act of March 3, 1879. Additional entry at St. Joseph, Michigan. NOVEMBER, 1935

# N. S. C. SAFETY SERVICES ARE YOURS - USE THEM

*Your membership in the National Safety Council places at your command a wealth of safety material that is available without charge. These services are yours. Use them often and use them all. They will help you make your accident prevention program more effective. They will help you reap full benefits from your safety work.*

**NEWS LETTERS**—These interesting monthly stimulators are divided into various industrial sections. Every member is automatically listed in one section and receives this section's News Letter. Any member may receive a reasonable number of additional copies without charge and may also receive copies of other sectional News Letters that are of interest and value to his particular type of industry. If you are not familiar with the different News Letters published a list will be gladly sent on request.

**POSTERS**—These colorful, striking and effective posters bring to the attention of workers safety lessons in picture form. They are easily seen, read and understood. Each member is entitled to a regular allotment. Sixty-three new and different posters are reproduced every month in NATIONAL SAFETY NEWS. It will pay you to make full use of the posters you are entitled to receive.

**CONSULTATION SERVICE**—Most members have some safety problems that are more or less special. Every member has the privilege of asking for the solution of as many safety problems as he desires. A trained staff of engineers is available to serve you in this connection. Use this service often, it will save you time and money.

**STATISTICAL SERVICE**—The keeping of proper accident records is an important phase of any well rounded safety program. Members may call upon the statistical division for help in formulating a system for tabulating accidents by cause, location, severity, etc. Members may also receive detailed reports on the trend of accidents in their own particular industry. Adequate accident records show you where special attention is needed. Any help of this nature desired will be gladly furnished.

**LIBRARY**—The National Safety Council's Library is often called the "million dollar library," because it has in its files a wealth of safety information available from no other source. Members are free to ask for information on any published material on almost any subject pertaining to accident prevention. In the majority of cases the material is immediately available and will be loaned to a member upon request.

**SPEAKERS SERVICE**—The Council maintains a complete and up-to-date list of capable speakers on all phases of safety work and accident prevention. The lists are kept in geographical order and by subjects so that a well versed speaker may be quickly obtained for any safety subject desired. This service has proved invaluable for local safety programs. Also, a member of the Council staff will be glad to go over any speech on safety a member is going to make and offer constructive criticisms.

**ORGANIZING FOR SAFETY**—An effective safety and accident prevention program should be well planned. All members are privileged to consult the Council at any time for aid in setting up new safety programs, revising old ones, arranging inter plant and inter department contests, planning safety meetings, methods of instruction—in fact, any matter pertaining to safety work.

*Listed here are a few of the services available to you as a member of the National Safety Council. In addition to these there are many others such as motion pictures and film strips, safety playlets, employment service, safety material for employee publications, etc. Information on any of these gladly sent on request. The Membership Service Department's sole function is to help you get the best value from your affiliation. Consult it often.*

**National Safety Council, Inc., 20 N. Wacker Drive, Chicago, Ill.**

NATIONAL SAFETY NEWS

# AT QUITTING TIME . . . INFECTION HOVERS OVER HALF-CLEAN HANDS



REDUCE YOUR RATE OF HAND INFECTION WITH LAVA SOAP—  
IT GETS HANDS CLEAN

If you could *make sure all hands get really clean* before your men leave the plant your rate of hand infection would be reduced!

Can this be done? Is there any safe, simple way to remove embedded grime and grease from minor abrasions on workers' hands? "Yes," say scores of industrial plants, "Lava Soap gets *all* the dirt . . . *every time*."

Lava is made specially by Procter & Gamble to clean grimy hands quickly and safely. It combines cleansing in its two elemental forms . . . dissolving plus scouring. Lava's lather *dissolves* the surface dirt. Its finely powdered pumice *rubs out* the ground-in dirt. Its glycerine and soothing oils *protect* the skin. Lava costs no more than ordinary soap . . . lasts much longer. Works well even in cold, hard water.

## LAVA SOAP

Gets Dirt Fast . . . Protects the Skin



### FREE!!

#### LAVA SAFETY POSTERS

Safety Directors of leading industrial plants in all parts of the country have requested these posters and are now on our mailing list. A new set of posters is mailed out every two months.

They are yours merely by filling out and mailing this coupon to Procter & Gamble Co., Dept. LNS-115, Box 1801, Cincinnati, Ohio.



Name \_\_\_\_\_

Position \_\_\_\_\_ Company \_\_\_\_\_

City \_\_\_\_\_ State \_\_\_\_\_

Number Posters Wanted \_\_\_\_\_

Would be Interested in Prices on Lava

A Procter & Gamble Product



**WHERE DANGER LURKS**



**CARNEGIE  
FLOOR PLATE**

For the many places about a plant where workmen's footing may be insecure—boiler room floors, bridges, crossings, platforms, stairways—Carnegie

Floor Plate offers effective protection. Its anti-skid surface is long wearing and is comfortable to stand or walk on. It provides easy traction for factory trucks. It cleans easily and drains completely. Available in suitable widths and thicknesses. Carnegie Floor Plate should have a very definite place in your safety program.

**CARNEGIE-ILLINOIS STEEL CORPORATION**

**PITTSBURGH • PENNSYLVANIA**

346

*United States Steel*  *Corporation Subsidiary*

NATIONAL SAFETY NEWS

# I AM THE CAR OF 1936

■ ■ ■ I have been designed to give you greater pleasure and greater safety. The first is accomplished by brilliant new styling and performance that will thrill you to your finger tips. The second results from better braking, better bodies and an almost universal use of Safety Glass All-Around. There is hardly a manufacturer who does not provide it as standard equipment.

Nothing in automotive history indicates more clearly the manufacturer's willingness to give the public what it wants than the remarkable rapidity with which Safety Glass All-Around has been made so readily and easily available. And there has seldom, if ever, been such general acceptance of an automotive product as that now accorded the Safety Glass made by Libbey-Owens-Ford. Buick, Cadillac, Graham, LaSalle, Oldsmobile and Pontiac use L.O.F Safety Glass All-Around in all models; Chevrolet uses it for all Safety Glass requirements; Auburn, Cord, Lincoln, Packard, Reo, Studebaker and Willys use it for a large part of their requirements. Such significant recognition of one Safety Glass can imply but one thing... that it is unquestionably a superior product. Libbey-Owens-Ford Glass Company, Toledo, O.



## LIBBEY · OWENS · FORD

*Safety* PLATE *Glass*



# National Safety News



Published monthly in the interest of accident prevention and the health of industrial workers

VOL. 32, No. 5

## CONTENTS FOR NOVEMBER, 1935

The President's Address— <i>John E. Long</i> .....	11
Let's Save 12,600 Lives— <i>Hon. Harold G. Hoffman</i> .....	13
Safety Had the Spotlight at Louisville .....	15
Officers of the National Safety Council, 1935-36 .....	18
A Full Time Job at the Norris Dam— <i>Curtis Billings</i> .....	20
Are Coal Mine Hazards Increasing?— <i>Daniel Harrington</i> .....	23
Every Entry Was a Winner in the Safety Derby .....	27
Award 120 Trophies in No-Injury Contests .....	31
Traffic Is Industry's Problem, Too— <i>I. L. Gilbert</i> .....	32
Preventing Tuberculosis Among Employees— <i>Charles S. Gallaher, M.D.</i> .....	33
Hydrogen Sulphide— <i>Ind. Data Sheet D-Chem. 16</i> .....	36
Heard at the Congress .....	69

### Regular Departments

Editorial .....	9	The Bulletin Board .....	40
The Managing Director's Page .....	10	Personals .....	49
The Safety Exchange .....	30	The Honor Roll .....	71
Industrial Health .....	33	With the Manufacturer .....	72
Safety Instruction Cards .....	34	The Buyers' Service .....	76
The Accident Barometer .....	35	The Safety Library .....	80

CARMAN T. FISH, Editor  
CURTIS BILLINGS, Associate Editor

STANLEY H. KERSHAW, Poster Editor  
C. H. MILLER, Advertising Manager

Copyright 1935 by National Safety Council, Inc. Printed in U.S.A. Published monthly. Entered as second-class matter June 1, 1921, at the Post Office at Chicago, Ill., under the act of March 3, 1879. Additional entry at St. Joseph, Mich.

The subscription price to members for extra copies of the NATIONAL SAFETY NEWS is \$4.00 per year. Single copies, 40 cents. Reduced quantity prices for yearly subscriptions and single copies on request.

Subscriptions are available only to members of the National Safety Council.

Member Audit Bureau of Circulation.

This magazine is indexed in the Industrial Arts Index.

Statements and opinions advanced in signed articles are to be understood as individual expressions of their authors, not those of the National Safety Council.

## National Safety Council, Inc.

(Cooperative—Non-Commercial—Non-Political—Non-Sectarian)

20 North Wacker Drive, Chicago, U. S. A.

New York Office, 9 East 41st Street

Office of the Education Division, 1 Park Ave., New York City

## National Safety Council Officers, 1935-1936

CASSIUS H. WATSON, M. D., President  
D. D. FENNEL, Vice-President for Public Relations  
HART E. FISHER, M. D., Vice-President for Health  
JOHN B. GIBSON, Vice-President for Safety Councils  
HON. HAROLD G. HOFFMAN, Vice-President for Public Safety  
ALBERT S. REGULA, Vice-President for Engineering  
A. V. ROHWEDER, Vice-President for Industrial Safety  
ALBERT W. WHITNEY, Vice-President for Education  
WILLIAM E. WORTH, Vice-President for Finance and Treasurer  
W. H. CAMERON, Secretary and Managing Director

### Executive Committee Members at Large

THE ABOVE OFFICERS AND:  
HAROLD S. BUTTENHEIM, *The American City*  
ROBERT I. CATLIN, *Aetna Casualty and Surety Co.*  
HOWARD GOODLEY, *American Standards Association*  
HARRY GUILBERT, *The Pullman Co.*  
C. F. LARSON, *Missouri Pacific Railroad*  
THOMAS H. MACDONALD, *U. S. Department of Agriculture*  
EDWARD J. MEHREN, *Portland Cement Association*  
I. W. MILLARD, *Industrial Gloves Corp.*  
GEORGE E. SANDFORD, *General Electric Co.*  
C. W. SMITH, *Standard Oil Co. (Ind.)*

### Safety Council Representatives

GEN. JOHN H. SHERBURNE, *Massachusetts Safety Council*  
WALTER DENT SMITH, *Delaware Safety Council*  
DONALD A. FINKBEINER, *Toledo Safety Council*  
EDWIN A. KEYSER, *St. Louis Safety Council*  
ROBERT L. SCHMITZ, *Louisville Safety Council*  
R. B. FORTUIN, *Lehigh Valley Safety Council*  
JAMES M. STRIKE, *St. Joseph, Mo., Safety Council*

### Sectional Representatives

A. I. ARMSTRONG, *Chemical*  
C. W. DEMPSEY, *Food*  
CAPT. E. W. FISKE, JR., *Marine*  
E. E. GRANT, *Paper and Pulp*  
WILLIAM C. KNOELK, *Street and Highway Traffic*  
J. A. PURDY, *Wood Products*  
C. T. WINEGAR, *Automotive and Machine Shop*

### Past Presidents

ROBERT W. CAMPBELL  
ARTHUR T. MOREY  
LEW. R. PALMER  
DAVID VAN SCHAAR\*  
RALPH C. RICHARDS\*  
CHARLES P. TOLMAN  
ARTHUR H. YOUNG  
MARCUS A. DOW  
LEWIS A. DUBOIS  
CARL B. AUEL  
CHARLES B. SCOTT  
WALTER G. KING  
HOMER E. NIEZ\*  
LT.-COL. HENRY A. BENINGER  
G. EUGENE PETTRONE  
CARL W. BERGQUIST  
JAMES I. BANASH  
JOHN E. LONG

\*Deceased

### Honorary Members

ROBERT W. CAMPBELL  
ASSOCIATION OF IRON & STEEL ELECTRICAL ENGINEERS  
ARTHUR WILLIAMS



# FIRST AID

## FOR SERIOUS BURNS

TRADE MARK **'TANNAFAX'** BRAND  
TANNIC ACID JELLY

Always fresh and ready for immediate application—'Tannafax' does not deteriorate. Non-oily—non-greasy—has a water-soluble base. Contains 0.5% phenol, which insures sterility and has a mild local anaesthetic action. Entirely eliminates the inconvenience and delay occasioned in preparing solutions.

*Indispensable to every complete First Aid Equipment in the Industrial Field*

'Tannafax' Brand Tannic Acid Jelly is issued in 4 gm., 20 gm. and 4 oz. tubes and 1-lb. jars, also in Unit Type packings.

**BURROUGHS WELLCOME & CO. (U.S.A.) INC.**  
9 & 11 EAST FORTY-FIRST STREET  
NEW YORK CITY

*Associated Houses:*  
LONDON (ENG.) MONTREAL SYDNEY CAPE TOWN MILAN  
BOMBAY SHANGHAI BUENOS AIRES

NOVEMBER, 1935



Send for New Booklet, "Tabloid First-Aid For Safety."

Name \_\_\_\_\_

Street address \_\_\_\_\_

City \_\_\_\_\_

State \_\_\_\_\_



*"Every 8 days  
GOGGLES  
save an EYE  
IN THE 'CATERPILLAR'  
TRACTOR PLANT"*

*Says  
H. S. SIMPSON  
Safety Engineer*

*"THE right kind of goggles, properly fitted, will prevent any kind of eye injury. I know, because here at the 'Caterpillar' plant, a safety goggle saves a worker's eye every 8 days . . . based only on the accidents in which even the strongest lenses have been cracked but the eye protected. We estimate that the proper use of goggles saves the company many thousands of dollars a year in compensation, medical and hospital expenses, lost time, training of new men and other ways in which eye accidents add to production costs." So said Mr. H. S. Simpson, the Caterpillar Tractor Co.'s well-known safety engineer.*

The eye safety record of the Caterpillar Tractor Co. clearly shows the value of supplying AO Goggles to every worker whose job contains even the slightest possibility of eye injury. Where eye hazards exist and goggles are not worn, you pay for goggles whether you buy them or not. Recognizing that no one type of goggle is suitable for all classes of work American Optical Company has developed a complete line of

eye protection equipment that gives a choice of 24 different standard types. They are strong, cool, comfortable. Men wear them willingly.

An AO Industrial Representative stationed in a branch office near you will be glad to recommend a practical eye safety program exactly fitted to the needs of *your* plant. Call him in.

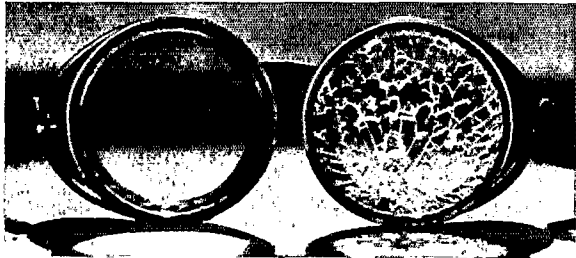

This AO Duralite-50 Goggle saved the eye of one of the workers in the Caterpillar Tractor Co. plant at Peoria, Illinois. The worker was pounding a jack out of a case, the jack flew from the casting, striking the Super Armorplate lens a terrific blow. Note that the lens cracked but remained intact. This goggle saved an eye—and a great deal of money.

# American Optical Company

Manufacturers, for more than 100 years, of products to aid and preserve vision. Factories at Southbridge, Mass. In Canada, Consolidated Optical Co., Ltd. Branch offices in all principal industrial centers

NOVEMBER, 1935

# NATIONAL SAFETY NEWS

Published by National Safety Council, Inc.

## A Challenge

**A** REDUCTION of 35 per cent in motor vehicle fatalities by 1940 is the goal for the safety movement proposed by Governor Hoffman of New Jersey.

It is an inspiring objective. When we translate this saving into human values as Governor Hoffman did at the Twenty-fourth Annual Safety Congress, figures have a new meaning.

Such a reduction in fatalities, with the corresponding decrease in crippling injuries which would also follow successful preventive effort, would be an immense contribution to human happiness.

The methods of achieving greater safety in a community are well known. They have been tried and found effective in more than one city. But they are not easy to carry out.

Commercial vehicles have shown improved experience because industry selects, trains and disciplines its drivers. Their record would have been even better had it not been for irresponsible private motorists who also use the streets.

When the state and municipality can exercise comparable control over all motor vehicle operators in the jurisdiction, the goal will be in sight.

## Variety

**N**OT long after J. C. Furnas rendered the safety movement an invaluable service by shocking an apparently shock-proof public, a member wrote to us asking the Council's attitude on the use of gruesome subjects.

The Council has no argument with those who use horrible examples to drive home the safety message. We feel, however, that those who depend entirely on this type of appeal will not get the best results.

The Council publishes an occasional repulsive poster. Some companies will not use them. Others will order them as fast as they are issued—and the bloodier the better.

Undoubtedly pictures of dripping finger stumps and suppurating wounds make some men work more cautiously—for a time at least. Others will pass by in a hurry when the poster display is repulsive.

The pitcher who makes good in the big league is the one who mixes them up. Few pitchers can last nine innings with only a fast ball. A good curve and change of pace helps a lot.

Some safety men have a fondness for a certain type of appeal and overwork it. Safety work must reach many differing mentalities and temperaments. It takes variety to keep them interested.

## The Last Congress and the Next

**B**EFORE one Safety Congress is over the question on everybody's lips is "Where will the next Congress be held?" It is gratifying to know that the Congress would be welcome in any of a number of cities.

The Twenty-fourth Safety Congress was a truly great one, thanks to those who took part in the programs and to the

citizens of Louisville who provided so inspiring and hospitable a setting. Not the least of the factors in the success of the Congress was the friendly cooperation of the Louisville newspapers.

A special committee is already making plans for the 1936 Congress. In selecting the city there are many essentials to be considered. A central location is always desirable, although other considerations cannot be ignored. One of these is the stimulating effect of the Congress on safety activity in that particular territory. Because of the size of the Congress and its unusual demands for meeting rooms and guest rooms, only a few cities can offer the necessary facilities.

The Council is grateful for the many cordial invitations which have been extended to the 1936 Congress.

## Speed's Passenger

**A**MONG the recent victims of accidents is Sidney Smith, a cartoonist widely known as the creator of "The Gumps." The cartoonist was driving to his farm in Wisconsin when a head-on collision occurred. The driver of the other car was too badly injured to tell how the collision occurred.

While the actual cause of the tragedy is a matter of speculation newspaper biographies of the deceased offer some significant facts. Smith was a skillful driver and he enjoyed getting the maximum miles per hour out of a car. He had been known to drive a thousand miles in one day.

Death had been a fellow passenger for some time before he seized the wheel.

## In This Issue

**I**T WAS Louisville this year! Much of the editorial content of this issue is directed to various phases of the Congress. The managing director has prepared an interesting summary of this great event of the safety year for his page. (Page 10.) And on page 15 one observer reports what he observed during the week. The colorful "Safety Derby" is described on page 27. On pages 18 and 19 you will meet the newly elected National officers and executive committeemen.

Governor Hoffman's stirring address at the Annual Meeting of Members is worth reading—even if you heard it at the Congress. It is published in full on page 13.

Not the least interesting side of the vast projects of the Tennessee Valley Authority is the intensive and successful effort being put forth to safeguard inherently hazardous operations. In this issue (page 20) Curtis Billings describes the program at Norris Dam. Another article, scheduled for an early issue, will describe the work at Wheeler Dam.

Coal mine fatalities have been fewer in recent years but conditions are developing which may cause a reversal of this trend unless energetic safety measures are instituted. (Page 23.)

NOVEMBER, 1935

# The Managing Director's Page

## A Glimpse at Our Congress

I SHALL never forget my first Safety Congress. I had long believed that we acquire our solid information through study and that technical information is not accumulated by listening to the reading of papers. My president, who agreed with me, said: "The published transactions of the Congress will give you all you need. Why spend time and money attending the meetings?"

Now that I have attended 24 Congresses, let me answer this question.

A Safety Congress is much more than an information bureau. It is a gigantic demonstration; a spectacular declaration of faith; a vehement expression of determination on the part of our movement to live and not to die, to swim and not to sink. The Congress is our way of saying that accidents everywhere can, must and shall be prevented. And at the Congress we also say *how* this is to be accomplished.

There were many evidences of the strength of the safety movement at the Louisville Congress. The attendance broke all records except for the 1930 Congress at Pittsburgh. There were not enough hotel rooms to accommodate the out-of-town guests. Over 800 were housed in private dwellings and

## INTERESTING ITEMS

Have you seen the latest edition of the "March of Time" movie feature? Be sure to see it when it comes your way. It was released October 21 in the larger theatres of the country. This edition includes a dramatization of the now famous Furnas article from the *Reader's Digest*,—"And Sudden Death." It is a most effective presentation, done with a fine sense of dramatic values. After you have seen this picture write the editors a word of appreciation, with the suggestion that more safety subjects be dramatized.

National newspaper publicity during Congress week reached an all-time high. This was due to several factors: The interesting subject matter of the speeches; the widespread interest in highway safety, and the willingness of the newspapers to cooperate. For the first time in several years our Congress dates did not conflict with the World Series baseball schedule. The safety movement is indebted to the Associated Press and to the radio for whole-hearted cooperation in publicizing the proceedings.

Attendance this year was 32 per cent ahead of the 1934 Congress. This may mean that we are on the road back to prosperity. Or it may mean that the re-awakened interest in the safety movement, as evidenced in so many fields during the past year, is beginning to catch on in earnest.

Staff editors are hard at work compiling the 1935 Congress Transactions. We hope to have the two volumes ready for distribution by the latter part of December. If you have immediate need for a copy of some special paper, write us. If there is an extra copy of the abstract in our files, we will gladly mail it.

Nine safety talks were made on the radio during Congress week in addition to the addresses of Governor Hoffman and William S. Knudsen which went out over the NBC red network. For taking the responsibility for these radio "spots," the Council is indebted to C. E. Pettibone, Lew Palmer, J. I. Banash, Charles B. Scott, A. V. Rohweder, Albert W. Whitney, C. W. Bergquist, C. B. Auel and Dr. C. H. Watson. F. C. Lynch and John B. Gibson talked before two of the leading civic groups in Louisville. These addresses were part of the big publicity program.

every club, apartment house and Y.M.C.A., was filled to overflowing.

The Louisville Safety Council, through its president, Mr. E. J. O'Brien, Jr., and manager, Mr. Frank W. Rodenheber, with the limitless cooperation of the directors and many other institutions in the city did everything possible to make this a truly great Congress. Through publicity and elaborate street decorations every man, woman and child in Louisville was aware that a great event was taking place.

The final edition of the program totaled 96 pages; there were over 400 names listed therein; 125 meetings and demonstrations; two big safety exhibits; and generous entertainment for the ladies and for all delegates.

Corporation members sent delegations from their many plants ranging from ten to seventy people. A group of one hundred and forty "worker delegates" was a unique feature. The Council itself entertained at special luncheons these "worker delegates" as well as its officers and hundreds of committeemen. The early morning classes consisting of two sessions on public speaking and two on safety in foremanship, and four on street traffic safety brought out thousands of delegates. These safety men were well repaid for their effort.

There were daily radio broadcasts from the Congress, and a national hook-up for Governor Hoffman of New Jersey and William Knudsen, executive vice-president of the General Motors Corporation.

Every phase of safety was discussed—home, school, industrial, aeronautical, street and highway. It was, as it ought to have been, the most constructive and comprehensive program the National Safety Council has ever produced for public consumption.

The mechanics of handling the Congress were exceptionally well taken care of. More than 1,000 separate signs were used to facilitate the conduct of the meetings. The Council produced a new type of exhibit demonstrating the possibilities of modern display. Both the Industrial and Public Safety Exhibits were given color and attractiveness by decorating them in "Kentucky Derby" style. Many prizes were awarded including two grand prizes at the banquet. Study committee of fifteen volunteers checked every meeting and mingled with the delegates. Already they have made exhaustive recommendations for the conduct of the 1936 Congress. Representatives were in attendance from Sweden, Cuba, Canada and other foreign countries.

This Congress was a real stimulant for the safety movement. The 7,000 persons in attendance testified to their sincerity and their desire to bring about a better understanding of how accidents happen and how they can be stopped.

Much of the information growing out of a Congress can be gleaned from the published transactions, but for the inspiration one must attend. The safety movement can live only on a combination of the two!

*W. J. Amey*

NATIONAL SAFETY NEWS



## The President's Address\*

By JOHN E. LONG

*President, National Safety Council, Inc.  
1933-35*

BEFORE I render on behalf of your Directors, Executive Committee-men and Officers an accounting of their conduct of the affairs of your Council during the past year, permit me to exercise my highly valued privilege of extending a most cordial greeting to you — to members, representatives of members, public officials and guests — all gathered here to attend the Twenty-Fourth Annual Safety Congress of the National Safety Council.

There can be no more convincing evidence of the real worth of the cause to which you have devoted yourselves, nor of the truly democratic character of the institution which you have created in its

service, than the strikingly large numbers in which each year you come together to dedicate yourselves anew to the support of that cause, and to determine how its service may best be advanced and enlarged.

I am once more impressed with the constantly increasing interest in the great Safety Movement and with your clear understanding that only through the personal participation and cooperation of all members of the Council can the cause of Safety be advanced as it should be and our organization retain its proper and important place in the lead of accident prevention effort.

Without such participation and cooperation, the best efforts of those to whom you have entrusted the activities and management of your affairs could

not have achieved anything like the same measure of success and the Safety cause would not be what it is today—a National movement of widest range and with practically unlimited possibilities.

Eleven years ago the National Safety Council held its Thirteenth Annual Congress in Louisville. It was an event that we have remembered with pleasure for the gracious hospitality extended to visiting delegates and for invaluable aid to the cause of Safety. To the officials and citizens of Louisville, I express the heart-felt appreciation of the folks who represent the Safety Movement. We are grateful for your continued interest in safety and for the cordiality of your welcome to this Congress. We know that we will profit by the interchange of experiences and by the fellowship of this gathering and we know that the City of Louisville will share richly in the benefits.

Let me take this opportunity also, of expressing the grateful appreciation of the Safety Movement to all who have contributed to the work. This Congress represents the cooperative efforts of many minds, freely given in a worthy cause. It makes available a vast fund of information which will aid us in the conduct of our work during the coming year. To the speakers and to those who have served on the various committees, we are indebted for a devoted service which makes the work of accident prevention a living, vital force.

I am especially pleased this year to note the presence of so many worker delegates. Let me emphasize the point that safety work is not merely an activity for a limited specialized group — the safety engineers. The work of preventing accidents is as broad as life itself. It is concerned in every activity of our daily lives, and it involves men, women and children of every age and of every profession and occupation.

Accident prevention in industry has been a joint endeavor of executives, of supervisors and of workers, with the safety men giving the benefit of their specialized experience and training. This splendid representation, I am convinced, is the underlying reason for the outstanding accomplishments of organized safety work in American industry. When we have the same wide participation in safety activities outside the factory walls, we will see amazing results.

It seems hardly necessary for me to remind you of the disheartening accident experience of the past year which has been displayed prominently in newspapers throughout the entire country. In recent months the world has been

\*Before the Annual Meeting of Members, Twenty-fourth Annual Safety Congress, Louisville, Ky., October 14, 1935.

startled by the accidental deaths of several prominent persons. An airplane crash in the Arctic wastes claimed the lives of a beloved humorist and an intrepid aviator. An automobile accident in Switzerland resulted in the death of a young queen whose character and charm had endeared her to her subjects. For the second time within two years, accidents brought mourning to the whole kingdom of Belgium. The same causes that bring death to humbler persons care nothing for the rank of the prospective victim.

I believe that the headlines of these tragedies have helped to bring home the seriousness of the accident menace and they must have convinced the public that an accident is no respecter of persons.

### An Appalling Picture

Industry has shared in the unfavorable accident trend but the bulk of the increase has been in public accidents, particularly those involving motor vehicles. It is appalling to realize that more than 100,000 of our people met accidental death last year. If this toll is not checked, it staggers the imagination to estimate the number of lives that will be lost and the number of people who will be crippled during our lifetime.

We cannot ascribe the increase in public accidents to any one cause alone, speed, alcohol, laxity of law enforcement—all of these have contributed their share to the heavier casualty lists of the past two years.

Speeds on the highways are definitely higher than they were a few years ago. We must face the fact that people are no longer satisfied to travel at 35 miles an hour and many of them are impatient at 45. The modern automobile is a marvelous piece of mechanism, but no amount of engineering skill can make it any safer than its operator. Any current model car can be driven much faster than the average driver's reflexes will permit handling with any reasonable degree of safety.

While speed is involved in only a small percentage of the total number of traffic mishaps, we cannot escape this significant fact—that nearly two-thirds of the fatalities to occupants of cars occur at speeds in excess of 45 miles an hour. Today an ordinary individual may have at his command more horsepower than was even dreamed of a few years ago—often far too much for his skill and judgment.

The other menace which is being brought forcibly home to us is the use of intoxicating liquors by motorists.

While the menace of the drunken driver should not detract our attention from the less sensational accident causes, we must include it among the reasons for the mounting death rate.

Alcoholism, like every other problem of human behavior, is far too complex to be solved by such a simple expedient as a jail sentence alone. Our trouble is not only the drunken driver, but the driver who has merely been drinking. It is going to be difficult to get public opinion to support drastic penalties for the motorist whose reaction time has been slowed down by two or three drinks.

Let me make it clear that the National Safety Council does not recommend a multiplicity of laws as a cure for present conditions. The Council, however, does recommend uniformity of traffic ordinances throughout the country, with just enforcement of reasonable regulations. The Council also urges the extension of drivers' license laws with adequate examinations as a means of keeping the obviously unfit off the highways and as a means of control over all motorists.

I think it is becoming increasingly evident to all of us that the present trend of motor vehicle deaths will inevitably result in more drastic methods of control over motorists. It may even amount to regimentation, regrettable as such measures would be. It remains to be seen whether motorists can develop sufficient judgment and self control to forestall more drastic regulation. We must remember that the laws now on our statute books, including many that are unworkable, are there because some evil called for correction.

Legislation, as we all know, is often a cumbersome and inflexible way of dealing with a situation. It is sometimes necessary but its limitations should be distinctly understood. It cannot take the place of a sound program of education for both adults and children.

### Motorists of the Future

Our schools have made remarkable progress in training children in self-preservation, but present methods of training do not go far enough. As these boys and girls grow up they will be motorists as well as pedestrians. I believe that in the very near future every high school will have in its curriculum a course in motor vehicle operation. With this training in the mechanics of operation, there should be splendid opportunities for instruction in the morals and manners of motoring.

The engineering side of safety is also important but if we depend upon physical improvements alone, the results are sure to be disappointing. Our wide straight superhighways are by no means free from tragedies. These modern highways, like railway grade crossing separations, are often the result of a demand for efficiency rather than safety. The elimination of delay seems to be a more impelling motive than the removal of danger.

### The Broad Field of Health

In the industrial field we find the problem of occupational diseases overshadowing many of our other problems. I am sure we would be happy if we could confine our activities to the humane work of prevention, but safety work cannot always be divorced from the complicated results of disability. So we find ourselves at times confronted with medico-legal situations. The safety movement has no sympathy with any effort to reduce accident costs by the avoidance of just claims but our whole system of compensation is complicated by some very human traits. Compensation, particularly in the field of occupational diseases where the responsibility is often vague, sometimes degenerates into a form of relief.

Industry must assume the responsibility for freeing its work places from sickness and accident hazards, but the employer has a right to be assured that he is not paying for a disability acquired elsewhere. I am convinced that public opinion will demand higher standards of industrial hygiene just as it began to demand safer factories and safer transportation twenty-five years ago.

Our knowledge of industrial health hazards is still extremely meager. It must be augmented considerably in the interests of both the employer and the employee. Compensation cannot be stretched to include sickness insurance, unemployment insurance and old age pensions without danger of the whole system breaking down. Other plans must be made for these social measures.

When the safety movement started, few of us realized how complicated it was to become. A comparison of the program of this congress with a program of twenty years ago will show how far we have traveled.

Guards and education absorbed practically all of our attention then, and it was very elementary education at that. The safety movement has gone to college

*(Please turn to page 54)*

NATIONAL SAFETY NEWS

# Let's Save 12,600 Lives!

## A Challenge to the Safety Movement

By HAROLD G. HOFFMAN  
*Governor of New Jersey*

**B**EFORE discussing the subject of highway safety let me go on record as being a most rabid enthusiast of the organization which, in my opinion, has saved more lives and eliminated more physical torture from the every-day world than any other non-profit group in the country: the National Safety Council.

Carrying the gospel of accident prevention from coast to coast, this body, supported entirely by membership contributions, has conserved so many lives, so many limbs, so many fingers, so many heartaches that the true worth of its work can never be evaluated.

When the Council began operations in 1913 the accidental death rate was 85.5 per 100,000. Today, in spite of an enormous multiplication of risk and exposure, that rate has been cut to 79.9. And I think the most concise way to appraise these labors for the past 22 years is to say that there are 190,000 people alive today who would have been dead but for the relentless efforts of this group.

On behalf of those who have been snatched from the hospital and the morgue, I salute the National Safety Council. And to those who think of civilized progress in terms of the steady reduction of this savage waste of life and limb in preventable accidents, let me urge you most fervently to get behind this undertaking in the most practical manner conceivable: by the financial support of membership.

All of which leads directly to my topic because the major portion of this achievement has been in the factory and the mill, the railroad and the mine. To a marvelous degree, serious injury has been minimized in even the most hazardous occupations through this intelligent, persistent war. So the upshot, as I see it, is that the wage earner of today, no matter how dangerous his work, stands a much better chance than he ever did of coming home tonight safe and sound *provided*—and this is where I come into the picture—

*Provided* he isn't run down by an automobile on the way home!

In other words, the real accident problem now is coming out of the factory into the street and highway where, last year, we set an all-time high record for sudden death.

This situation interests the public as the victims; it interests you safety engineers as their defenders; it interests me as a public official because I feel that the reduction of traffic accidents is as much a matter of public welfare as was the elimination of the fever-breeding swamp or the plague-spreading rat. A life is just as precious whether it be saved by wiping out a mosquito hole or a treacherous highway intersection. And since motoring now kills some ten thousand a year more than that old bugaboo,

malaria, the point requires no elaboration. We simply must make the hazards of traffic at least as inconsequential as we have already made the hazards of public plague.

This is obvious from the fact that in 1934 the automobile *driver*—and please don't miss the emphasis on *driver* rather than on *automobile*—managed to kill, maim and injure more than enough people to repopulate the whole state of Colorado.

To put it another way, every week of the year we killed more victims on the highways than were lost in the recent Florida hurricane which impressed the nation so graphically as a grave catastrophe. And the startling thing about it all is that since at least 1925, each year except one has been worse than the year before.



Conspicuous among those who participated in the Twenty-fourth Annual Safety Congress were: (left to right) William S. Knudsen, executive vice-president, General Motors Corporation; W. H. Cameron, managing director, NSC; Dr. C. H. Watson, president-elect, NSC; John E. Long, retiring president, and Hon. Harold G. Hoffman. Gov. Hoffman's address before the Annual Meeting of Members is printed herewith.

Plain horse sense tells us that this must stop. Two successive years with more than one million traffic casualties apiece is such a wanton, uncivilized waste of life that drastic action becomes imperative. And I can think of no better place in which to recruit and solidify that action than here.

### A Call to Arms

With this ghastly experience casting its prophetic shadow on the years to come, I am taking it upon myself to sound a call to arms.

This summons is in the form of a proposal—a proposal which may seem too ambitious to some, too modest to others—a proposal which will involve widespread co-operation, unflagging effort and painstaking diligence; but one which will pay a fabulous dividend in an amazingly brief time.

This proposal, my friends, is that the National Safety Council declare a definite objective for each state in the union:

*A reduction of at least 35 per cent in motor vehicle deaths by the end of the year 1940.*

The details, the complicating problems, the methods of such an endeavor need not be gone into now: you safety men know them as well or better than I. What I should like to emphasize is, first, that the time is ripe for such a movement; second; that this goal can reasonably be achieved; third, that its accomplishment will be enormously profitable in terms of dollars and cents as well as blood and bones, happiness and security.

The time is ripe because general acceptance of the need for drastic action is being fanned into flame by the public-spirited press. Newspapers the country over are giving constructive attention to the problem, and in the past few months I have noticed motor safety articles in at least five leading magazines approaching 15 millions in aggregate circulation. On the heels of such education there will come a lively demand for remedies.

The goal is reasonable because we have already seen more difficult ambitions realized. In the period when adult fatalities jumped 23 per cent, accidents among school children dropped 19 per cent. While deaths among private drivers—I believe some call them "pleasure drivers"—have increased 40 per cent, commercial vehicle accidents have come down 26 per cent. In each instance reductions have been effected by the methods so well known to safety men: by consistent education, coordinated efforts: the time-honored organized campaign.

Indeed, these methods are already bearing fruit in some of the more aggressive cities and states which have taken the traffic bull by the horns. You will understand my pride, I am sure, when I say that my own state of New Jersey is one of these. We rank only 45th in territorial area, yet our situation between New York and Pennsylvania makes us a veritable gangplank between the first and third cities of the country with a traffic problem that is staggering. Despite this—and despite the nation-wide increase of 15 per cent in highway accidents last year—we kept our rise down to 3½ per cent. Actually, we had fewer motor deaths than in 1929, 1930 or 1931 with a much greater traffic flow.

This, of course, we credit to organized safety efforts. For the truth is that on the highway, just as in the factory, the mine or the railroad, we can claim a standard technique which if honestly, diligently and patiently applied, will not only check the accident rise but will actually reduce it.

Needless to say, New Jersey is not unique; several other states and numerous cities, large and small, have made genuine progress in the reduction of highway accidents. To cite a single example, Milwaukee, last year's winner of the Council's contest, has not only cut traffic deaths in one year but in four years hand-running.

So to those who say that this proposed 35 per cent reduction is too stiff, I say that it is already being done. So far this year no less than 17 states have cut their deaths from 17 to 30 per cent under last year. Of our 13 larger cities, 8 show decreases for the first seven months: a total of 301 lives saved in these communities alone. And among the smaller cities you will find that the number not having a single death this year is exactly *double* last year's total!

### Backward States

On the other hand, to those who feel that the goal is too soft—that five years is too long a period for so little improvement—I say that the field for progress is still enormous. As you well know, there are still some 14 states which require no driving license—and 10 which fix no minimum age for the operator of an automobile, thereby making no distinction whatever between a kiddie car and a 120 horsepower sedan.

Such laggards cannot help but detract from the progress of the more advanced. And even in the more advanced, I know, from long experience, that the inertia of

large masses of people, the disinterest of some officials, the limitation of funds available, and the thousand and one expected and unexpected obstacles which hamper any movement all combine to make it advisable to refrain from setting the goal too high.

### Modernizing the Highways

On top of this we are faced with a sharp increase in the number of vehicles on our highways and, especially, an increase in their total annual mileage. Hence I feel that if you take all these factors into consideration, you will agree that my objective is neither too high nor too low.

What we mustn't allow ourselves or the public to forget is that its realization will not come from "prayer and fasting" alone. Hard work is involved. Our streets and highways must be modernized for present day traffic if we are really convinced that the horse and buggy has gone for good. We need controlled rights of way, the separation of highway grades, the separation of opposing vehicular flows, the substitution of 20th century lighting for the mid-Victorian glimmer of our heavily-travelled roads, and many other safety features so well known to you highway and traffic engineers.

I needn't tell you that automobiles must be maintained in a condition comparable to that when delivered by the manufacturer—or that enforcement agencies must be properly organized and adequately equipped in order to cope with today's conditions—or that education must be pressed into every nook and cranny of the land—or that uniform driver's license laws and, above all, uniform traffic laws are a crying need. To be sure, many of these things will materialize more quickly as more of our states acquire up-to-date motor vehicles bureaus: not mere fee collecting agencies, but departments dedicated to safeguarding the public on the highways. And we will doubtless have more bureaus of that caliber when business and civic organizations, womens' clubs and churches unite in this war and demand such assistance from their localities.

These details you all appreciate: my sole function is to urge you to work and fight for them in the face of every obstacle. Through legislation, through administration—above all, through *education* all the way from the kindergarten to the university's senior class, we must hammer, hammer, hammer on the

*(Please turn to page 60)*

# Safety Had the Spotlight in Louisville

**T**HE largest and best attended Safety Congress since 1930 took possession of the city of Louisville during the week of October 14 to 18. More than 6,000 delegates from every state in the Union and from several foreign countries attended the sessions. There were two other conventions meeting in Louisville simultaneously with the

Congress and the fall race meet at Churchill Downs was also in progress, but safety occupied the center of the stage.

Naturally, such an influx of visitors to the city taxed the capacity of the local hotels but the local Congress Committee handled the difficulties with exceptional skill. Many delegates had to put up

with less luxurious hotels than they had been accustomed to, but these minor inconveniences were invariably accepted in good spirit. Many delegates also found it necessary to secure accommodations in private homes which were made available for the Congress. Many a delegate so quartered found that southern hospitality was not confined to the pages of fiction.

Harrassed hotel clerks were besieged by scores of travelers who wanted sample rooms or even a place to stay for the



CASSIUS H. WATSON, M. D.  
President-Elect, National Safety Council

NOVEMBER, 1935

Cassius H. Watson was born in 1878 at Brooklyn, N. Y. He passed his boyhood in Danbury, Conn., graduating from the Danbury High School in 1896.

He entered the University of Pennsylvania in 1897 preparing for medicine. During his college career he participated in rowing, football and other forms of athletics, representing his University in a number of events. Upon graduation he was appointed Harrison scholar in biology. Taking a position as instructor in biology, natural sciences and mathematics at Pratt Institute High School, he was able to arrange his time so that he could complete his four year course in medicine at the Long Island College Hospital.

Upon graduation from medicine he entered upon a two-years' internship at the Long Island College Hospital. The succeeding years included clinic work in Manhattan and Brooklyn, minor teaching assignments at Long Island College Hospital, with the continuance of the position at Pratt Institute as a lecturer on science.

He became interested in safety, per se, at the time of his first association with the New York Telephone Company. About 1913 the Employees' Benefit Plan of the American Telephone & Telegraph Company was formed, and Dr. Watson, who did a great deal of the accident surgery for the New York company, was asked to devote a certain amount of his time to the headquarters office where a small medical unit was instituted. This unit grew very rapidly.

Dr. Watson's increasing association with the safety movement led to his election as vice-president of the Council for health a few years ago. He has long taken an active interest in Red Cross affairs and has been intimately concerned in the development of first aid measures throughout the Bell System. He is a member of various medical associations and holds a fellowship in the American College of Surgeons.

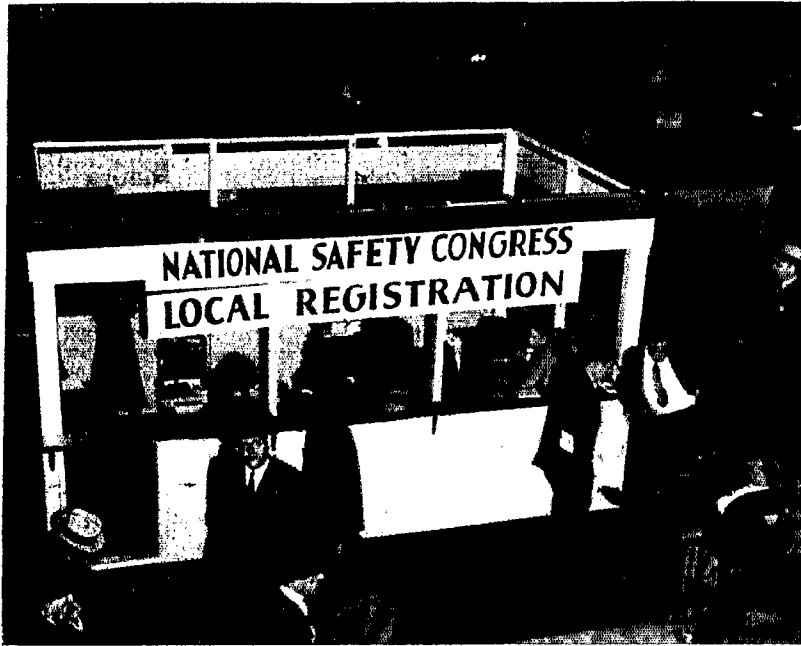

The registration desk at the Seelbach, one of the three headquarters hotels.

night, but all rooms in downtown hotels had been engaged far in advance.

The provision of adequate meeting rooms provided another problem for hotels because of the number of sectional meetings which comprised the Congress. The combined facilities of the Brown, Kentucky and Seelbach hotels were needed to hold the many sessions.

That the Council was welcome in Louisville, there could be no doubt. There was no mistaking the cordiality with which Mayor Neville Miller, and E. J. O'Brien, Jr., President of the Louisville Safety Council, and General Chairman of the Greater Louisville Safety Congress Committee, welcomed the delegates to the city at the Annual Meeting of Members.

It seemed like a pre-depression Congress when the ballroom of the Kentucky Hotel was filled for the annual meeting. President John E. Long, whose address summarized the progress of the safety movement and its immediate problems, was followed by two speakers of unusual prominence: William S. Knudsen, executive vice-president of General Motors Corporation, and Governor Harold G. Hoffman, of New Jersey, who has served the Council as chairman of the Street and Highway Traffic Section and was elected Vice-President of the National Safety Council in charge of Public Safety.

Mr. Knudsen divided his address, "Safety and Manufacturing," into two parts: the prevention of accidents in

industry, and the prevention of accidents in which automobiles participate. Mr. Knudsen attributed the improvement in industrial accident experience partly to improved machine and tool design, but even more to better training of workmen and foremen. To the safety engineers he gave much of the credit for being the prime mover in this improvement.

Mr. Knudsen questioned some of the accusations made against speed as the outstanding cause of accidents, pointing out that in European countries where cars are much smaller and lighter than ours, and not capable of such great speed, the rate of automobile deaths per 10,000 motor vehicles runs from two to four times our rate. Suggested means to help the situation are the education of the driver, licensing of the operator, and compulsory inspection of motor vehicles.

In conclusion, Mr. Knudsen praised the Council for its part in the promotion of safety: "Your organization is not something invented today or yesterday: it is a living, strong body, whose efforts of study and action should be behind every move to reduce accidents throughout the land."

The goal of a 35 per cent reduction in motor vehicle fatalities by 1940 was urged by Governor Hoffman whose address is reprinted in this issue.

The Monday morning addresses were broadcast from Station WAVE over an NBC hook-up.

## President Watson's Speech of Acceptance

IT IS a great honor to become the President of this very wonderful organization. An assignment of this sort is fraught with such obligations that I fear an already well-developed inadequacy complex may become supplanted by a still further faulty psychology. I shall hope, however, to profit by the becoming modesty and splendid achievements of my predecessors, and making use of their productions and their decisions, be able to carry out the term of my administration satisfactorily.

I have many times marveled at the humanitarianism which is the lone stimulus that has maintained the enthusiasm of our members for this great work of safety. Safety may be thought to have become supreme among the altruistic endeavors of our people, and the National Safety Council symbolizes both the sentiment and the action needed for its advancement.

The National Safety Council probably contacts intimately, directly or indirectly, more individuals than any similar group in the country. The appeal of its objectives meets a response, however transient, in the intelligence of every one. The philosophy behind the execution of its objectives is based on the theory of repeated directions of the insight of people, to the ideals which experience has shown, insure safety. We too often take safety for granted and pursue our daily comings and goings with little thought as to hazards. People will always be confronted by the elements of human frailty, moral laxity, material loss and lack of integrity of the constituent elements in an unfriendly environment. To meet these elements which are opposed to safety, it is necessary that we intelligently use our brains and sense organs to prevent these agencies from functioning. The doctrines which experience and authority have shown lie behind the ideals of adequate safety, concern both the individual as well as the group.

We must think of the safety of others, even more intensely than we think of our own personal safety. Once the safety of others is assured, individual safety becomes a fact. So it is, that the National Safety Council cooperating with our Government and all other interested agencies strives to establish and maintain safety on the sea, safety in the air, safety on the land and safety in the depths of the earth.

*B. H. Watson*

Sectional meetings and subject sessions started Monday afternoon. In all, 110 sessions with some 360 speakers were listed in the printed program.

Seven subject sessions with extremely practical topics were sponsored by the ASSE-Engineering Section. These were: Fire Prevention in Industry, Safety in the Small Plant, Safety Training, Maintaining Interest in Safety, Heat Exhaustion, Finding and Correcting Accident Causes, and Occupational Diseases.

Early morning classes have become a regular feature of the Annual Safety Congress. They have proved to be an excellent way of including sessions of widespread interest so that they will not conflict with other meetings. Tuesday and Wednesday morning at 8:30, Dr. William P. Sandford, of the Sandford Speech Organization, Chicago, delivered two lectures on public speaking in safety work. Safety in Foremanship was the topic of the Thursday and Friday morning lectures conducted by H. S. Bigelow, vice-president, Sales Analysis Institute, New York City. These lectures demonstrated the effectiveness of the conference method of teaching safety to foremen and its application to all industries. The subject matter covered the psychological and emotional factors which are important in understanding the science of human relationships.

On Tuesday evening, the ballroom of the Kentucky Hotel was again filled for a program of safety talkies. "Everybody's Business," produced under the supervision of the Plymouth Division, Chrysler Corporation, presented a forceful plea for safe driving. It is impressive without being gruesome in its portrayal of the sins against safe driving which are responsible for accidents. This film is entertaining throughout and its producers have succeeded in avoiding the trite and the insipid.

A new film produced under the supervision of the Fireman's Fund Insurance Company, San Francisco, was also shown. This one-reel picture tells the touching story of how a reckless driver injures an entire family and cripples "Jimmy." It depicts in a highly emotional manner the results of a thoughtless act.

"Death Takes No Holiday," a film strip with sound, produced by the National Bureau of Casualty and Surety Underwriters, was also included in the program. This strip gives a clear picture of the scope and tragic character of the automobile accident situation and presents many positive suggestions for improving traffic conditions.

NOVEMBER, 1935



Through the exhibit arranged by the Library of the National Safety Council at each annual Congress more and more members are learning of the vast amount of information which is available for the asking.

As an added attraction, "The March of Time" was also presented. Among the news features dramatized by this remarkable production was the story of "—And Sudden Death," showing how this remarkable article came to be written, with one scene from the article — omitting the more gruesome parts.

At the Annual Banquet on Wednesday evening Dr. John L. Davis, of New York, again addressed an appreciative audience. His selection as the speaker for the second consecutive banquet was the result of requests from many members who were charmed by his humor and philosophy at the Cleveland Congress. Clifford Davis, vice-mayor and commissioner of fire and police for Memphis, had been scheduled as toastmaster but was unable to be present. In his absence Dr. C. H. Watson filled the double role of president-elect and toastmaster.

A pleasant part of the evening's program was the presentation of the plaque won by Louisville in the National Safety Council's Inter-City Plant Contest. The trophy was received on behalf of the city by E. J. O'Brien, Jr., president of the Louisville Safety Council.

Other evening functions during the week were the President's Reception and dance on Monday evening, a session devoted to child education on Tuesday evening around the general topic, "Are Children Safe in Your Community?" Thursday evening was given over to the annual Fun Fest which taxed the capacity of the Casa Madrid.

An innovation this year was a special

luncheon for worker delegates. For several months prior to the Congress employers had been urged to include workers among their representation at the Congress. Many of these delegates had been sent to the Congress by their companies as a reward for their services to safety. The meeting was addressed by John E. Long, retiring president of the Council, and by W. H. Cameron, managing director.

The Street and Highway Traffic Section had a crowded schedule lasting from Monday afternoon until Friday noon. On Monday afternoon a general traffic session was held with Governor Harold G. Hoffman, of New Jersey, and Dr. Miller McClintock, Director of the Bureau of Street Traffic Research, Harvard University, as the speakers. Following this meeting the section adjourned for committee meetings. Two sessions were held jointly with the Institute of Traffic Engineers, and while the industrial delegates were busy with the early morning classes in public speaking and foremanship, the public safety delegates were holding a traffic school. Other public safety problems were discussed in the sessions of the Vehicle Fleet Section and in a special subject session on Industry and Its Motor Vehicle Accident Problem.

Few of the sessions attracted more interest than those devoted to industrial health. One meeting dealt with First Aid and Health Service in Industry, another with Heat Exhaustion, and a third with Occupational Diseases.

(Please turn to page 60)

# Executive Officers of the National Safety Council

## Elected at the Twenty-Fourth Annual Safety Congress

- PRESIDENT:** Cassius H. Watson, M. D., medical director, American Telephone and Telegraph Company, New York City.
- VICE-PRESIDENT FOR PUBLIC SAFETY:** Hon. Harold G. Hoffman, Governor of New Jersey, Trenton, N. J.
- VICE-PRESIDENT FOR PUBLIC RELATIONS:** D. D. Fennell, consulting engineer, Chicago.
- VICE-PRESIDENT FOR HEALTH:** Hart E. Fisher, M. D., F.A.C.S., chief surgeon, Chicago Rapid Transit Company, Chicago.
- VICE-PRESIDENT FOR SAFETY COUNCILS:** John B. Gibson, director of publicity, Western Electric Company, Hawthorne Works, Chicago.
- VICE-PRESIDENT FOR ENGINEERING:** Albert S. Regula, executive secretary, Industrial Relations Counsellors, Inc., New York City.
- VICE-PRESIDENT FOR INDUSTRIAL SAFETY:** A. V. Rohweder, superintendent of safety and welfare, Duluth, Missabe & Northern Railway Company, Duluth, Minn.
- VICE-PRESIDENT FOR MEMBERSHIP:** R. T. Solensten, vice-president, Elliott Service Company, New York City.
- VICE-PRESIDENT FOR EDUCATION:** Albert W. Whitney, associate general manager, National Bureau of Casualty and Surety Underwriters, New York City.
- VICE-PRESIDENT FOR FINANCE AND TREASURER:** William E. Worth, works manager, Twine Mills, International Harvester Company, Chicago.
- SECRETARY AND MANAGING DIRECTOR:** W. H. Cameron, Chicago.

### Executive Committee Members at Large

#### *The above officers and:*

- HAROLD S. BUTTENHEIM**, editor, *The American City*, New York City.
- ROBERT I. CATLIN**, The Aetna Casualty and Surety Company, Hartford, Conn.
- HOWARD COONLEY**, president, American Standards Association, New York City.
- HARRY GUILBERT**, director, Bureau of Safety and Compensation, The Pullman Company, Chicago.
- MERLE C. HALE**, director of industrial relations, General Motors Corp., Detroit, Mich.
- WILLIAM C. KNOELK**, chairman, Milwaukee Safety Commission, Milwaukee, Wis.
- EDWARD J. MEHREN**, president, Portland Cement Association, Chicago.
- I. W. MILLARD**, president, Industrial Gloves Corp., Danville, Ill.
- C. W. SMITH**, director, Safety Department, Standard Oil Company (Indiana), Chicago.
- W. H. WINANS**, manager, Industrial Relations Department, Union Carbide and Carbon Corp., New York City.
- G. E. SANFORD**, General Electric Company, Schenectady, N. Y.

### Safety Council Representatives

- DISTRICT 1**—General John H. Sherburne, Attorney, Boston. (Massachusetts Safety Council.)
- DISTRICT 2**—Walter Dent Smith, president and manager Delaware Safety Council.
- DISTRICT 3**—Donald A. Finkbeiner, Community Traction Co., Toledo, Ohio. (Toledo Safety Council.)
- DISTRICT 4**—Edwin A. Keyser, St. Louis Dairy Co. (St. Louis Safety Council.)
- DISTRICT 5**—Robert L. Schmitt, Louisville Car Wheel and Railway Supply Co., Louisville, Ky. (Louisville Safety Council.)
- CLASS B AND C COUNCILS**
- R. B. Fortuin, Pennsylvania-Dixie Cement Corp., Nazareth, Pa. (Lehigh Valley Safety Council.)
- James M. Strike, St. Joseph Railway, Light, Heat and Power Co., St. Joseph, Mo. (St. Joseph Safety Council.)

### Sectional Representatives

- A. L. ARMSTRONG**, Eastman Kodak Co., Rochester, N. Y. (Chemical.)
- C. W. DEMPSEY**, Liquid Carbonic Corp., Chicago. (Food.)
- CAPT. E. W. FISKE, JR.**, Socony-Vacuum Oil Co., Inc., New York City. (Marine.)
- E. E. GRANT**, Crystal Tissue Co., Middletown, Ohio. (Paper and Pulp.)
- WILLIAM C. KNOELK**, Milwaukee Safety Commission, Milwaukee, Wis. (Street and Highway Traffic.)
- J. A. PURDY**, Michigan Mutual Liability Co., Detroit, Mich. (Wood Products.)
- C. T. WINEGAR**, Dodge Bros. Div., Chrysler Corp., Detroit, Mich. (Automotive.)

### Past Presidents

- Robert W. Campbell, Los Angeles, Calif.
- Arthur T. Morey, St. Louis, Mo.
- Lew R. Palmer, conservation engineer, The Equitable Life Assurance Society, New York City.
- Charles P. Tolman, consulting engineer, Boyle, Tolman & Travis, New York City.
- Arthur H. Young, vice-president, United States Steel Corp., New York City.
- Marcus A. Dow, manager, Department of Safety and Personnel, Greyhound Management Company, Cleveland, O.
- Lewis A. DeBlois, consulting engineer, New York City.
- Carl B. Auel, manager, Employees' Service Department, Westinghouse Electric & Manufacturing Company, East Pittsburgh, Pa.
- Charles B. Scott, president, Bureau of Safety, Inc., Chicago.
- Walter G. King, manager, Safety Division, American Optical Company, New York City.
- Lieut.-Col. Henry A. Reninger, special representative, Lehigh Portland Cement Company, Allentown, Pa.
- C. Eugene Pettibone, vice-president, American Mutual Liability Insurance Company, Boston, Mass.
- Carl W. Bergquist, superintendent of public relations, Western Electric Company, Hawthorne Works, Chicago.
- James I. Banash, consulting engineer, Chicago.
- John E. Long, superintendent of safety, The Delaware & Hudson Railroad Corp., Albany, N. Y.

# Officers of the National Safety Council

1935-36



D. D. FENNELL  
Vice-President for Public  
Relations



HON. HAROLD G. HOFF-  
MAN, Vice-President for  
Public Safety



HART E. FISHER, M.D.  
Vice-President for Health



JOHN B. GIBSON  
Vice-President for Safety  
Councils



ALBERT S. REGULA  
Vice-President for  
Engineering



A. V. ROHWEDER  
Vice-President for Industrial  
Safety



R. T. SOLENSTEN  
Vice-President for  
Membership



ALBERT W. WHITNEY  
Vice-President for Education



WILLIAM E. WORTH  
Vice-President for Finance  
and Treasurer



W. H. CAMERON  
Secretary and Managing  
Director

NOVEMBER, 1935

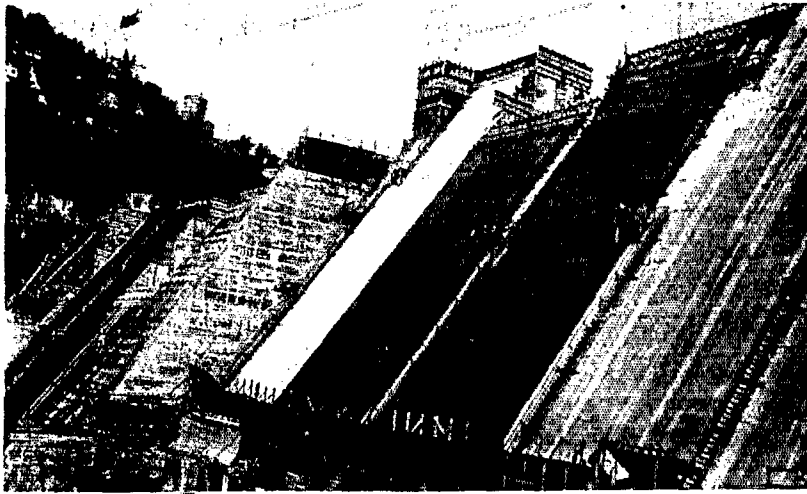

Looking west across the down-river face of Norris Dam one sees the substantial staggered ladders up the blocks to the pouring levels, the staunch baffle platform extending along the base, the head towers of the cable ways at upper left, and the circular bin for cement at the right of the towers.

**M**UCH has been written about the social, economic and political aspects of the experiment now being carried out in the Tennessee Valley by the Authority established by Congress two years ago; but little has been said about the huge construction project itself—and less about the care being taken to prevent the injury and death of men on the works. But this last aspect is surely one of the most interesting; the safety program might well be held up as a model for the heavy construction industries of the United States.

Since my visit included only the dam at Norris and the basin above, this article will be limited to a description of safety work there; but the Tennessee Valley Authority, as an integral function of the Personnel Division, is conducting a vigorous campaign not only in the fields of industrial and public safety but in the home as well. This program is under the supervision of D. F. McMurchy, director of safety, who is assisted by field safety engineers located in each of its principal construction areas and resident safety supervisors on the major operations.

Right at the outset it must be pointed out that the most inherently hazardous occupations on Norris Dam have been made comparatively safe; the rigging crew, for example, installed and has maintained two electrically controlled cableways consisting of 16 cables each stretched 300 feet above the valley bed and running 2000 feet from head tower to tail tower without a fatality, without even a serious accident. As a result of the safety program, the most prolific types of accidents have changed from those caused by falling objects and falls of persons to the less serious types of

## A Full-Time Job at Norris Dam

By CURTIS BILLINGS

stepping upon and striking against objects and handling objects, although the height of the dam has steadily increased with an accompanying increase in inherent hazards.

The dam itself, located below the confluence of Cove Creek, the upper Clinch River, and the Powell River, will impound a huge lake shaped like a thin hand with three fat fingers. The irregu-

lar shoreline of the lake will measure 705 miles. The waters, held back during wet seasons, will be liberated during other parts of the year so that a constant stream will be available to turn the turbines in generating plants at other dams to be constructed down the river and at Wilson Dam at Muscle Shoals. In contrast with Norris, Wilson dam is a "run of the river" dam, capable of gen-

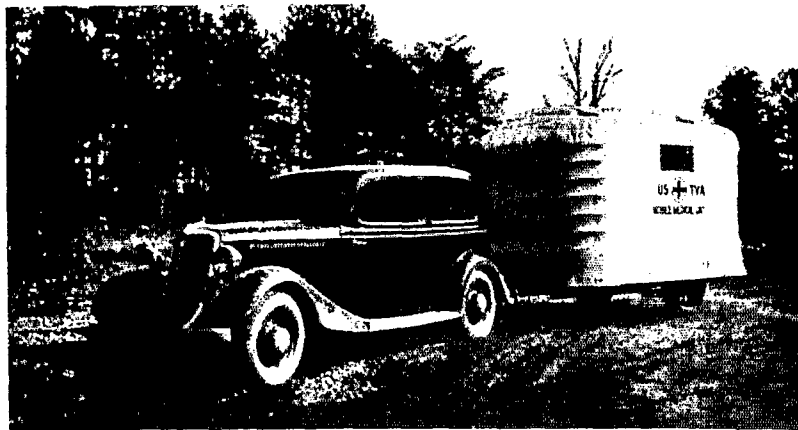

On every main job in the Norris area a fully equipped first-aid station is provided. Even the smallest job has its first-aid kit and trained worker. In addition, several of these portable stations are constantly traveling from job to job.

NATIONAL SAFETY NEWS

Not the least interesting side of this vast project is the program for the protection of men engaged in work that is inherently hazardous

erating great power when the river is at normal stage, but little during the dry season.

Since over 53,000 acres of land above Norris Dam will be inundated as the reservoir fills, the clearance of this basin of wood and underbrush, the relocation of highways and railways, the construction of bridges and dikes, and the trans-planting of communities adds to the activity in the region. As a matter of fact, almost as many men are employed in the basin as at the dam itself.

When you have electricians, riggers, mechanics, quarrymen, woodsmen, drillers, grouters, carpenters, concrete layers, and a host of laborers engaged in their various hazardous jobs throughout a mountainous, backward region 80 miles from tip to tip, you have a safety job on your hands. If you do not believe it, ask H. J. Fulmer, safety engineer, who has the accident prevention activities on every project in the Norris area and the safety of more than 3000 men under his supervision.

When Mr. Fulmer was appointed to his position on December 18, 1934, he did not find the area a shambles wherein men were being injured and killed right and left and the prevention of accidents was pooh-poohed as a vain and idle wish. Not at all. Those in charge had laid out the project with the greatest care, and an effort was being made to incorporate safety as an integral part of the plan. But Mr. Fulmer did find some



H. J. FULMER  
Safety Engineer  
at the  
Norris Dam

conditions which needed correction and needed it badly. For the most part they were conditions which only a safety engineer of long experience would recognize. Upon pointing out these condi-

NOVEMBER, 1935

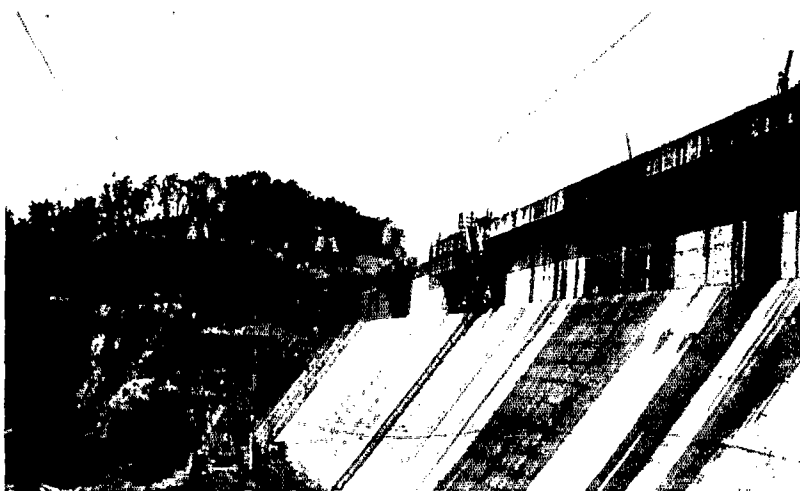

A close-up view of the top of the completed blocks showing the well-supported stairways from the ladders up over the protruding lip. Note that the stairways have railings.

tions to the management, they were corrected without waiting for an accident to occur, and that is the essence of safety work. Space will permit a discussion of only a few of the specific things that were done for safety on this project. But they are typical.

The dam itself will reach slightly less than 2000 feet between two hills. It is being poured in sections or blocks of solid concrete which stretch 48 in line across the valley.

The up-river face of these blocks is, of course, perpendicular; the down-river face slanting away from the base at a very small angle.

As the blocks are poured, the electricians, carpenters, concrete workers, engineers, and others must climb on ladders located on the down-river face to reach

the pouring level. Since this face measures more than 200 feet in height as the block nears completion, a slip would result in almost certain death. The workman would roll and pitch down the steep side to the base of the dam or a baffle platform full of debris below.

As the height of the dam increased, the problem of safety on these ladders became more serious. The need for uniform construction, handrails, even rung spacing, and a means of minimizing fatigue on the ladders was evident. Through the cooperative efforts of Mr. Fulmer and the management a set of standards covering the material, construction, and anchorage of ladders was adopted and is now being used throughout the project. The sections of the long ladders on the down stream face of the

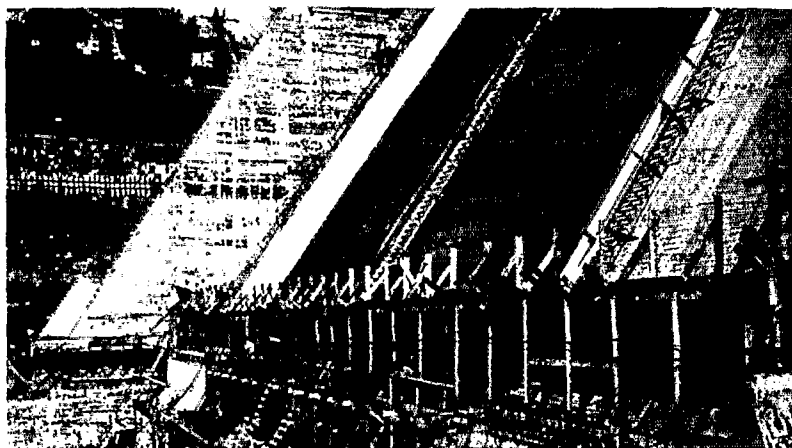

This photograph shows an important detail of the baffle platform—a heavy mesh wire fence running along the top to hold back any debris which might drop on the men working below.

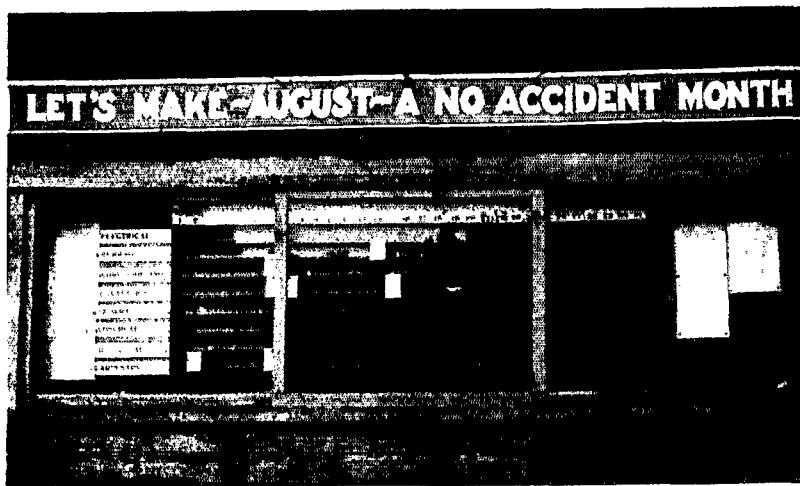

A huge bulletin board is at the entrance to the works at Norris Dam. The departments, each represented by a toy automobile, compete against each other for the best no-injury record of the month.

dam are now staggered and are equipped with substantial platforms placed at approximately 50 foot intervals. These platforms not only provide a resting place for the men passing up and down but would, in the event of a fall, tend to reduce its seriousness. At quitting time when the ladders are full, a man at the top with a heavy kit of tools on his shoulder could fall and knock from the ladder many of the men below him. Staggering the ladders reduces the number of men so endangered. The platform also reduces the distance a man would be likely to fall. All ladders are of clear lumber, planed to eliminate splinters. The rungs are of uniform size and of ample strength, evenly spaced. The handrails are substantial and at a constant height from the rungs.

Since carpenters and others work below at the base of the dam on the spillways and on the generating plant, Mr. Fulmer recognized that tools or debris might easily fall from the top of the blocks and roll down the side endangering them. A baffle platform of heavy timbers all along the base of the blocks to catch such objects was erected. The amount of concrete, bolts, pieces of lumber, and other materials which have collected on the top of this platform testifies to the wisdom of this suggestion.

Another outstanding hazard was in the quarry from which the aggregate for the concrete is taken. The quarry has been cut into a solid limestone hill. The drillers worked on ledges sometimes only a few feet wide with a sheer drop of from 80 to 100 feet beside them. Through the cooperation of the quarry superintendent, a policy was adopted which

provides that the ledges in which men work be no narrower than 12 feet, overburden be kept back from the face, hazardous areas roped off, and head protection furnished to men subjected to a falling object hazard, and respirators to those working in dusty locations around the crushing and mixing plant. Numerous other devices such as safety belts,



The lower photograph shows a 40-inch gyrator, perhaps the largest ever used. Located in the main quarry, it is protected on three sides by stout railings. No man is allowed to enter the crushing area while the machine is in motion. Note the hook. Suspended from a crane, it is used to relieve a jam. The operator, shown above, stands on a platform behind a railing and guides the hook by a rope.

goggles, railings, and adequate walkways are provided on the work, and mechanical guards have been provided in the shop.

But, as has been said, the Norris area was no slaughter house even before the organization of a safety department and the appointment of a resident safety engineer. The corrections mentioned represent some of the outstanding specific contributions of the safety engineer to physical safeguarding. In addition, Mr. Fulmer has secured better housekeeping at the dam and on the projects in the area, and this has produced a marked effect on the frequency of puncture wounds and similar accidents.

The program for safety education in the Norris area has been very complete. However, few general safety meetings have been held on account of the difficulty of assembling men from four shifts on widely scattered operations into a central location. Crew meetings are held on the various projects, during which hazards peculiar to the crew are discussed. Occasionally meetings of superintendents and foremen are held in which Mr. Fulmer uses a novel method of convincing these men that unsafe conditions and practices can be found on their jobs.

Mr. Fulmer uses a pocket camera. If he sees a man breaking a safety rule such as failing to wear his goggles or his metal hat in the quarry or notices a condition of poor housekeeping, unsafe piling of material, etc., he snaps a picture. At the meetings of foremen these photographs are used with telling effect when a foreman claims that all his men are thoroughly trained in safe practices and that no violations of safety rules exist on his part of the work. Snap shots are also used to note safe as well as unsafe conditions. The use of photographs in this manner has been of great educational value and in addition provides a pictorial record of the work. They are also valuable in the investigation of serious accidents.

But the safety engineer is not a snooper, or a detective. Nor does he file complaints at headquarters. His aim is to help the supervisors and workmen to locate and remedy those conditions and practices which cause accidents, and to refrain from criticizing until he has a constructive suggestion that he is sure will work.

Another effective educational feature used on the various operations in the Norris area is an accident analysis form. These forms are so arranged that by placing a single mark in the proper

(Please turn to page 67)



Scenes like this have been less frequent in mine communities in recent years. But is the improvement in explosion experience to be only temporary?

## Are Coal Mine Hazards Increasing?

**C**AREFUL analysis of the main causes which enter into the killing and maiming of our coal miners—falls of roof and coal, haulage, explosions, electricity, machinery, explosives, shaft accidents, surface accidents, and miscellaneous accidents—shows that real progress in preventing fatalities has been made in only two classifications—explosions and the use of explosives. It also shows that slight progress has been made in the prevention of miscellaneous accidents and of accidents in and around shafts. However, essentially no progress has been made in reducing injuries from falls of roof and coal or from surface accidents, while there has been a definite increase in the rates for haulage accidents and those due to electricity.

Explosion disasters, including fires, have been identified luridly with coal mining, and for many years they were considered an inevitable part of operation. However, the main effort toward

This article is published by permission of the Director, U. S. Bureau of Mines. Not subject to copyright.

NOVEMBER, 1935

bringing about safety in coal mining has been directed to the prevention of these dreadful occurrences, apparently with a measurable amount of success in the past few years. Early in this century many of our most disastrous coal-mine explosions were caused by ignition of gas or dust or both by shooting off the solid during the working shift, using black blasting powder or dynamite, almost universal coal mine practice. In time, most of our coal was cut by machines (now 85 or more per cent of our bituminous coal is machine-cut) and the very much safer permissible explosives largely displaced black blasting powder and dynamite in blasting coal. Moreover, some mining states and many progressive mines did much if not all blasting when the working personnel were out of the mine. As a result of precautions taken, relatively few major coal-mine disasters have been caused by blasting for the past 20 years.

Unfortunately, however, while the material lessening of solid shooting and

By **DANIEL HARRINGTON**  
*Chief, Health and Safety Branch, Bureau of Mines, Washington, D. C.*

of the use of black blasting powder and dynamite, along with the extension of the firing of shots on the off shift, gradually decreased the occurrence of explosion fatalities from these causes, extension of the use of undercutting and other methods of mining coal tended to speed up the loosening of coal; with it, the release of considerable quantities of gas and dust and explosions of gas or dust by open-light ignitions held the rate of occurrence of fatalities from explosions and fires at least as high as when solid blasting with dynamite and black blasting powder during the working shift were in effect.

The introduction of the electric cap lamp some twenty years ago into gassy mines largely eliminated the open light from the most dangerous mines, hence materially reduced the occurrence of explosions of gas and dust by open light ignition. Again there was relatively little relief from fatal accidents from gas and dust explosions, because about as soon as the use of electric cap lamps reduced open-light ignitions of gas and dust, expanded use of electrical equipment in coal mines gave a new igniting agent in the form of the electric arc. Disasters continued to occur with unabated vigor, there being many very disastrous coal-mine explosions in the years 1924-30, the period of maximum intensity of introduction of electrically-operated mining machinery.

Many of the explosion disasters with excessively heavy loss of life in this period were caused by gas or dust ignitions by electric arcs. The fiscal year 1928 had a particularly bad record in this respect, as 282 or 82.5 per cent of the 342 people killed in explosions in our coal mines were killed in explosions started by electric arcs. In fact, for the 5-year period from July 1, 1927 to June

Our coal mines are now embarking on new methods which, if not carefully safeguarded, may precipitate another series of disasters

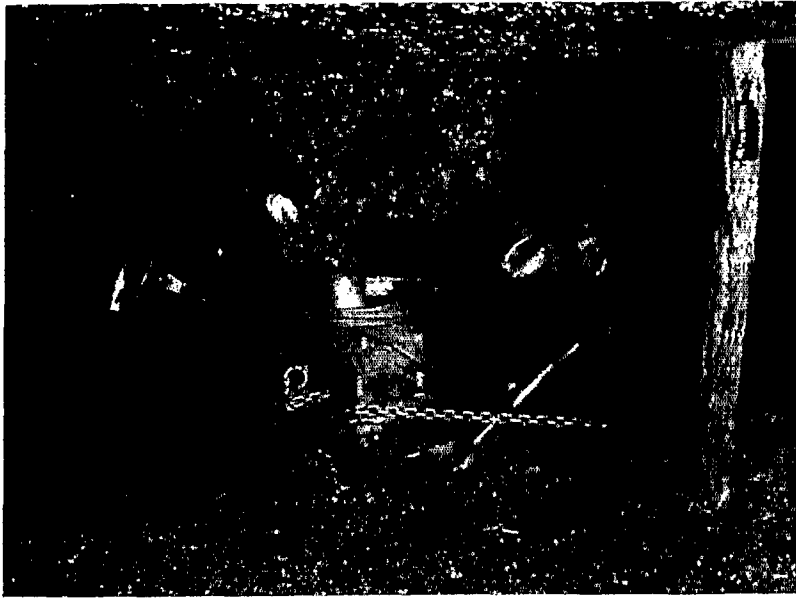

Dry undercutting creates large quantities of dust.

30, 1932, out of 984 persons killed in explosions in our coal mines, 683 or 69.4 per cent were killed in explosions started by electric arcs. Fortunately, the number killed in explosions of electrical origin was but 11 (or 12.7 per cent) in the fiscal year 1932, the last year of the above mentioned five-year period. In the fiscal year 1933 there were but 25 persons killed in coal-mine explosions of electrical origin and but 21 in the fiscal year 1934, the last period for which final data are available. It now appears that at last we have (at least temporarily) practically conquered *all* of the main causes leading to coal-mine explosion ignitions. At any rate their destructiveness has been decreased, as there were but 7 fatalities from major coal-mine explosions and fire disasters in the one major disaster in the calendar year 1933, but 22 in the two major disasters in the calendar year 1934, and but 28 in the three major disasters in 1935 to August 1.

While the past three years have been relatively free of major coal-mine disasters (and it is due to this fact chiefly that our coal-mine fatality rate has been kept low) there are good reasons to fear that the lull is but temporary. Our coal mines are now embarking on new methods which, if not carefully safeguarded, are likely to precipitate another series of disasters. The extension of mechanization has brought about a persistent demand for blasting coal during the working shift (frequently with little

safeguarding), which is a definite recession from progress made in the past. Unquestionably much of the considerable reduction of fatalities from explosions due to blasting in the past 25 years has been due to the fact that much of the blasting has been done on the off shift and by shot firers. The Gresford disaster in Wales in September, 1934, with 263 deaths, as well as several other recent British coal-mine disasters, are suspected of having been caused by blasting with the shift in the mine, and British coal-mine blasting practice is now being subjected to severe scrutiny.

### Accidents from Explosives

Early in the present century coal was obtained chiefly by being blasted from the solid, using black blasting powder or dynamite with squibs or with so-called safety fuse, practically all blasting being done by the individual miner when and largely as he pleased. This naturally resulted in considerable numbers of blasting accidents. In those days sightless, armless, and legless ex-miners were by no means an unusual sight and fatalities were numerous. Later some mines took the blasting out of the hands of the individual miner and entrusted it to shot firers. This was of some aid in reducing individual explosives accidents, especially when the shot firer worked on the night or other off shift, although many individual shot firers were killed through foolhardiness, or negligence.

The introduction of cutting machines with resultant changes in explosives practice, especially the material decrease in the size of the explosive charges used, was a long step in decreasing blasting accidents. But the development of permissible explosives after the Bureau of Mines came into existence in 1910 and their displacement of black blasting powder and dynamite unquestionably was one of the most far-reaching advances in the present generation. The gradual introduction of electrical blasting methods in conjunction with the use of permissible explosives has also aided much. The mines of the anthracite region of Pennsylvania have had a much worse accident rate from the use of explosives than the bituminous industry.

During recent years there have been some disquieting tendencies in mine blasting practice. Among them is the introduction of black blasting powder in some consolidated form instead of its former granular shape but having many of the dangerous characteristics of ordinary black blasting powder. The exigencies of mechanized mining appear to demand blasting during the working shift, using some form of blasting device or even ordinary explosives. This is bound in time to result in disaster as it has been doing in British coal mines for several years.

### Falls of Roof and Coal

In the early days of the present century coal-mine roof-fall accidents were in large part due to the violent blasting practice then in effect. Shooting off the solid with heavy charges of black powder or dynamite would severely shatter the roof as well as the adjacent coal, with shots in one place in a mine jarring down the loose material in another place upon hapless workers at almost any minute of the shift. With restriction of blasting to the off shift and using of shot firers this hazard was largely reduced, as the blasting concussions then occurred only when few if any men were in the mine and usually the several hours which intervened before the working shift came on allowed much of the loose material to fall.

With the advent of cutting machines, and later of permissible explosives, smaller charges of explosives were used, thus helping to protect the roof, but there were relaxations as to the time and other precautions of blasting, and with the increasing size and deeper cover of mines and seasonal or other rush de-

mands for coal, mines or parts of mines were "guttled," squeezes, creeps, bumps, and other influences tending to keep mine roof in a broken tender condition also intervened, and with blasting allowed at all times in the day, the loose roof material was being more or less continuously shaken down on the workers.

Another serious trouble in connection with falls of roof is the fact that the man in charge of a coal mine usually feels that his personal reputation and future advancement depend upon getting out cheap coal, so the practice is to take the cream in the form of the "easy" coal (usually advancing rooms) and leave the "skim milk" (the pillars or the deficient coal) to the next fellow who follows in charge of the mine. The roof of many a mine has been ruined by this by no means unusual practice, and when the "other fellow" tries to extract long-standing pillars he usually finds the coal broken and friable and the roof treacherous in the extreme. Very often the "other fellow" too takes the "easy" way by failing to pull the pillars systematically, seldom are they kept in line, timbering is not always kept in shape (in some cases not enough timber or not the right kind is supplied), supervision of the miner's attack on the pillars is frequently lax, and he is prone to take



Inserting an electric detonator in cartridge of explosive. The tendency to carry on shot firing while men are in the mine is likely to offset the benefits of permissible explosives and improved methods.

A coal-mine official showing a workman where and how to place props. Falls of roof remain one of the most serious hazards of mining.



"easy" coal back from the face even when by doing so he may precipitate premature falls.

With the advent of mechanized loading numerous new conditions were introduced, many of them unfavorable to the prevention of roof-fall accidents. The highest rate of roof-fall accidents in the history of coal mining in the United States occurred in the period 1927-32, or about exactly coincident with the peak of the increase of mechanized loading in the United States. The worst roof-fall fatality rate in the history of coal mining in the United States was encountered in 1930, but fortunately this has receded rather rapidly.

The worst disappointment met by the coal mine safety worker in the past 30 years is the fact that in rate of occurrence of the major cause of coal-mine fatalities, falls of roof and coal, there has been essentially no progress nationally, even though locally there are numerous instances of improvement. For a generation around 50 per cent of all coal-mine fatalities have been caused by falls of roof or coal, and at least 99 per cent of the cases have been one-man accidents. If it were not for numerous instances in which mines, with what might be termed extremely bad roof conditions, have through intensive timbering and equally intensive supervision been able to operate with relative freedom from roof-fall accidents, one might be driven to the conclusion that nature had so arranged affairs that these accidents simply couldn't be avoided.

### Haulage Accidents

Our civic authorities are now deeply concerned with the fatality rates of street and highway traffic. Our mines have essentially the same problem, and the solution seems to be about as difficult as with surface traffic. Early in the present century much of the coal-mine

haulage was by mules and relatively small combination wood-iron band pit cars. Even then, haulage fatalities, while only about one-half as numerous as the fatalities from explosions, were far too frequent.

With the gradual speeding up of practically all phases of coal production, haulage accidents increased, reaching a high rate during the heavy production war period, a much higher rate during the period of lower production, 1921-26, and a peak in the period of rapid expansion of mechanized loading, 1926-30, and receding slowly during 1931 to 1933, the last year for which comparable figures are available.

In the mines of thirty years ago the cars held ordinarily not more than two tons of coal, and the car itself usually weighed less than a ton. Today larger cars, weighing much more than one ton when empty, are in general use. When one of those large cars gets out of control the danger is much greater than with the car of thirty years ago.

One feature which has intensified the risk is that frequently larger cars and heavier locomotives have been installed without increasing the size of track rails and ties. Also in more recent installations wider and higher locomotives have been placed in service without in-



A safety man-trip on a 20-degree haulage slope. Haulage is still a serious source of accidents in coal mines.

creasing the side or top clearance of the haulageways.

The much more extensive use of the trolley-locomotive system during the past two decades is unquestionably responsible for a considerable part of the higher haulage accident rate. The bare trolley wire has in many instances caused workers to be thrown under cars or between timbers and cars. In addition the trolley system has caused many deaths charged to electricity, and has initiated several mine explosions. While the trolley locomotive has several advantages from an operating standpoint, it certainly is ultrahazardous. Consideration should be given to the possibilities of the compressed air, the storage battery, or possibly in time the Diesel engine or some similar type of engine to displace the trolley locomotive.

### Electrical Contact Fatalities

Beginning about 1905 electrical appliances were introduced rather rapidly in coal mines, the fatality rate from this cause increasing to its present rate between 1910-15. Somewhat fewer than 100 persons are killed from this cause each year in the coal mines of the United States. The trolley-locomotive system, with its deadly bare wire, usually unprotected, accounts for nearly half of the contact electrical deaths in our coal mines. This is a hazard which should not be allowed to continue year after year.

Insofar as major mine fire and explosion disasters are concerned, the electrical hazard seems to have been fairly well

curbed—at least for a time—but it seems probable that most of the credit should go to rock-dusting and good luck rather than to precautions with electrical equipment. The hazard of death from contact with electricity, while apparently lessened slightly in 1934 and 1935, remains fundamentally with probably greater powers for destruction in the future than in the past unless our coal mining people become awake to the menace of the unguarded trolley wire and poorly guarded electrical equipment now so widely used.

Mining, especially coal mining, is an occupation little understood by persons not actively engaged in it, and not any too well understood by persons who have made it their life work. These generalizations are more definitely applicable to the United States than probably to any other country. The vast area of the United States, with the varying conditions under which mining is carried on in the different regions, many of them hundreds of miles apart, makes it almost impossible for any one person to have anything like an adequate knowledge of the industry as a whole.

Safety in mining has made less progress than in many other so-called hazardous industries. This is true of many other countries as well as in the United States.

Certainly in this day no thinking person familiar with mining will accept the explanation that mining is an unsafe occupation because of its inherent hazards and must continue to be ultrahazardous. There are now available so many in-

stances of long-time operation of individual mines without accident occurrence or with low accident frequency and severity that we know now that proper procedure will reduce accident occurrence at least one-half or even three-quarters from recent performance.

That definite progress is being made in this direction is proved by numerous facts. In 1932 (the latest year for which data are available) 70 per cent of our bituminous coal came from mines that operated throughout the year without a fatality. There was but 53.6 per cent of this non-fatality production in 1931 and but 49.8 per cent in 1930. Also in 1932 all of the fatal accidents in bituminous mines came from properties producing less than one-third of the total output for that year.

The safety man in coal mining has for years been in the position of the mythological toiler whose job was to roll a huge ball up hill. Relaxation on his part would allow the ball to roll back and crush him. Scores of influences have intervened to block safety efforts; the alternating periods of feverish desire for maximum output, as during the war period and the opposite extreme of painful deflation of the years 1920-21 and 1930-33 have seriously handicapped efforts to prevent accidents. The "sprags" placed on safety endeavor by the numerous labor disturbances which have confronted coal mining in the past thirty or more years certainly can't be overemphasized. The cutthroat competition which has prevailed for most of this generation has interposed almost insuperable bars to progress. The "economies" necessary to allow coal sales at cut prices are largely assessed on personnel, not only in wage cuts but also in retrenchments in safety.

Rapid and often ill-considered changes in mining methods, with the placing of ill-fitting equipment in mines without sufficient training of workers in the new methods has often blocked the efforts of those trying to make the mines less hazardous. Numerous other instances of similar nature might be cited.

However, notwithstanding the up-hill work of the past and some possible shadows which appear to be falling across the future, there is reason for hope. Many of our progressive mines have shown definitely that coal mining can be carried on with relative safety. The fellow who fails to "get on the band wagon" may be forced out of business. After all, safety pays, and ultimately unsafe mines will be found impossible to operate.

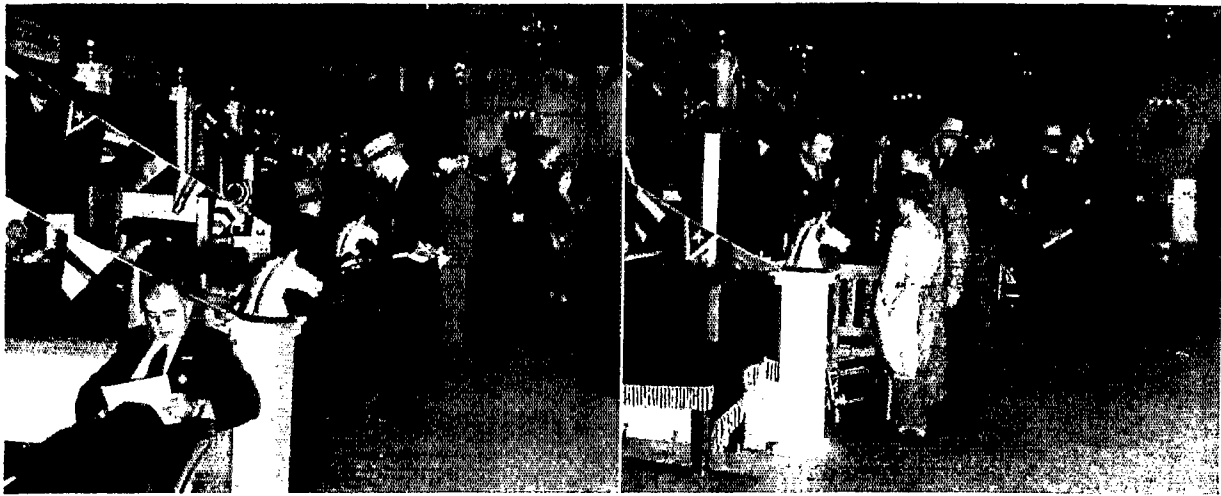

## Every Entry Was a Winner in the Safety Derby

By C. H. MILLER

**T**HOSE of us who always seem to pick the wrong horse at The Kentucky Derby have often dreamed of that "perfect race" where every entry would be a winner. Such a dream was made a reality at the 24th Annual Safety Congress and Exposition. There were 63 entries in the "Safety Derby" and every entry a winner.

The atmosphere at both exhibits was decidedly "racy." The uniformed jockeys, bright colored caps worn by all exhibitors, festive pennants and the many unique displays of the exhibitors who carried out the "Safety Derby" idea, made the exposition this year one of the most interesting and successful yet staged at an Annual Safety Congress.

At the industrial exhibit in the Brown Hotel every conceivable item for the promotion of safety in industry was on display. The well known manufacturers of head and eye protection have brought out many new developments during the past year which were studied with interest by scores of delegates. Willson Products, Inc., showed their improved line of composition cup goggles known as the RR styles, together with improved air line respirators and new composition lens retaining holder welding helmets and handshields. One of the outstanding features of this exhibit was their new bag respirator, which carries the Bureau of Mines' approval for lead dusts.

In keeping with the spirit of the Safety

Derby, the American Optical Company's safety goggles were housed in its "Stable of Eye Protection Winners." Each "Winner" had a separate "stall" and the place of honor was held by the Ful-Vue Safety Goggle, originally introduced by the company. In addition to displaying its line of safety goggles the American Optical Company also provided its visitors with the means of testing the merits of some of their products. One demonstration apparatus showed the heat absorbing qualities of Calobar and Noviweld glass. Another demonstrated the strength of the new armorplate lenses by means of a drastic drop test.

The featured item at The Safety Equipment Service Company's display was the Super-Drednaut 50-S goggle with deep curve lens and non-rubber headband. Their gloves, suits, sleevelets and leggings as well as other accident prevention items were also shown.

The Chicago Eye Shield Company showed a complete line of Cesco welding, chipping, and dust goggles, also Healthguard respirators and sand-blast masks. A new toe guard was a featured item at this exhibit.

In the field of fire prevention equipment the American-La France and Foamite Industries, Inc. displayed a line of portable fire extinguishers suitable for

different classes of fires. A large chart showing these different classes of fires, supplemented with materials representative of each class of risk and the most suitable type of extinguisher proved quite an educational feature in this exhibit. They also showed chemical engines, generators, fire department supplies and safety devices, including gas masks and inhalators.

Wil-X-M'F'G Corporation displayed an automatic machine showing the operation of Wilbur extinguishers together with a complete line of their various models.

A real innovation in fire fighting equipment was the new hand extinguisher employing carbon dioxide known as Lux Model Two, as shown by Walter Kidde & Company. This new unit is particularly designed for handling small electrical and oil fires. Other equipment of interest was a complete Lux automatic system using the Lowe release and a fairly complete line of Lux portable models and the new Kidde pure water and anti-freeze extinguishers.

In the more general line of safety equipment, Mine Safety Appliances Company had on display four new safety developments—the New Hydrogen Sulphide Detector, the New Lightweight Half-Hour Oxygen Breathing Apparatus, a new Combination Hose Mask, and Comfo Lead Dust Respirator. This company also showed the McCaa Oxygen

Breathing Apparatus, H - H Inhalator, masks of all types, gas indicators, detectors and recorders, goggles, protective hats and caps, safety shoes, electric cap lamps and first aid kits, cabinets and supplies.

The delegates found a number of new products and developments in the line of equipment handled by the Davis Emergency Equipment Co., Inc. First aid kits, dressings and supplies of all kinds as well as canister type and air line type gas masks, inhalators, gas indicators and representative samples of linemen's climbing tools, body belts, safety straps and other items of this nature were on display.

Protective clothing designed to fill the requirements of the jobs that are "different" was given special prominence in the display of the Standard Safety Equipment Company. Here were also found the Biever respirator, Watters Mask for sandblasting, and other respiratory equipment. Salt tablets, safety guards, Perks safety washers and goggles were exhibited.

The Bishinger-Koehler Manufacturing Company made an attractive display of their standard line of breathing apparatus, hose masks and inhalators. Also several new protective face pieces.

The E. D. Bullard Company booth featured the development of the Golden Gate Bridge, which has enjoyed a safety record of more than 1,500,000 man hours under the most hazardous conditions without a fatality. Pieces of Bullard safety equipment used on this job were displayed. Moving pictures demonstrating the safety program, together with a selection of still pictures, artists' sketch and a scale model of the bridge, rounded out the exhibit. Included in this display were the Bullard cylindrical first aid kit, hard boiled hats, caps and fire helmets, a complete line of gas masks, Signalmaster sirens both for stationary and vehicular installations, Venex snake bite outfits, protective cream and other products manufactured by this company.

Again the chief part of the exhibit of the Pulmosan Safety Equipment Corp., was their very complete line of respirators. The right respirator to serve every respirator need is their model and it is hard to think of any condition for which they do not have the correct device.

The principal products in the display of the B. F. McDonald Company was the McDonald safety hat. This new hat was placed on the market in March of this year and is winning its way fast in the mining, oil and construction fields. The crown of this new hat is made of Dural which is hardened aluminum. It

is light in weight, waterproof and non-corrosive. The hat comes with or without lamp brackets.

Other safety hats were found in the exhibit of The Strauss Company, Inc. Foot guards and safety belts designed for all industrial hazards where men are working above or below the ground were also featured in this display.

As I looked at the many displays of safety shoes I thought of the unshod Ethiopian going barefooted into the battle and wished that they might have the splendid protection which our American workers have in their fight against foot accidents. The "Grand-daddy" of all boots which is 7 feet 6 inches high and 5 feet 4 inches long, actual size 168, was housed in the booth of The Safety First Shoe Company. This boot is a perfect fit for a man 33 feet 8 inches tall. No one was seen wearing it.

Two new members, the H702 Australian kangaroo oxford with the ISCO steel safety box toe and the H735 new non-slip sole were new developments of the International Shoe Company, manufacturers of Hy-Test safety shoes. This manufacturer feels that quite a decided step forward has been taken in safety shoe manufacture by the use of Kangaroo leather which they claim is the strongest leather for its weight that is known. The Hy-Test non-slip sole is particularly well adapted for packing

feature at the Lehigh Safety Shoe Company's display where their complete line of safety shoes for all kinds of work was shown.

Before the invention of the non-slip soles and heels, workmen were forced to use such appliances as hob nails, metal cleats and spikes fastened to their soles to prevent slipping. This meant added weight and discomfort and sometimes injury to floors. The well known Gro-Cord and Raw-Cord soles and heels which have been developed by The Lima strength of the new armorplate lenses by this company displayed at their exhibit overcomes all the objections of the old-time makeshifts.

The safety style show, staged by the Safety Equipment Section at their Wednesday afternoon meeting, was an interesting and instructive innovation in safety meetings. Protective apparel and various other items of safety equipment were brought to life and action in this educational display of what the "well-dressed worker" will wear and how and when he will wear it in 1936. The show was well attended and provided a splendid opportunity of demonstrating the wide range of uses for special protective equipment.

While on the subject of protective clothing, in addition to their catalog line of Steel Grip gloves and safety apparel, the Industrial Gloves Corp.



plants, ice plants and dairies where there is a slipping hazard in conjunction with dampness.

The Brown Shoe Company brought to the exhibit this year a safety toe shoe for women. In the G50 model this company has constructed a shoe with the same strong durable steel toe as used in the men's product and has also succeeded in keeping that important quality of style in the shoe.

An all-rubber safety shoe was a new

displayed a number of their protective devices designed to special specification of individual mills. A new line of safety wearing apparel was also introduced by this exhibitor, consisting of trousers, jackets, and "heat breakers." The "heat breaker" is a close, snug fitting garment developed to overcome the objection to loose clothing.

New styles in safety leggings for steel plant and foundry workers and another style of new leggings for miners were



displayed by The Safety Clothing Company. New styles seemed to be the feature of this exhibit, for here we found also new styles of asbestos gloves and leather welding gloves for both acetylene and electric welding and other new numbers of asbestos and fireproofed clothing. A recently developed helmet for babbiting was also on display.

No safety exhibition would be complete without a display of safety ladders and scaffolding. In this important field The Patent Scaffolding Company displayed their Gold Medal line of platform ladders, step ladders, extension and single ladders, extension trestles and staging. Other scaffolding products were displayed in miniature on the unique model representing a building under construction. It showed their safety suspended scaffolds used for exterior masonry erection; their steel sidewalk protection canopy and light duty junior scaffold machine used in tuckpointing and general maintenance work. Through a cut-away section, the visitor could also see an example of a securely constructed, fireproof, interior scaffold, built of Gold Medal Steel Tubelox material.

The main feature of the Protective Equipment Inc. display was a complete line of Tilley Safety Ladders. Particular stress was given to the thorough bracing and construction of their improved safety platform ladder. Each step of this ladder is reinforced with four combination pressed steel knee, tie and angular braces. The bottoms of the front and back side rails are reinforced with steel rivets.

A complete display of safety signs always means that Stonehouse is on the job. Many new signs have been added to their already complete line so that every hazard now has its safety sign developed by Stonehouse Signs, Inc.

NOVEMBER, 1935

The exhibit of the Bradley Washfountain Company consisted of a foot-controlled stainless steel Washfountain accommodating ten users at one time, a six-person precast Granito Washfountain, a three-compartment semi-circular group shower, a drinking fountain, and a Bradley street shower.

Three different manufacturers displayed equipment of particular interest to the public utility industry. In addition to the "Burr-Key-Bilt" line of safety belts and straps for linemen, the R. H. Buhke Company showed many other products of safety equipment for construction and maintenance work.

W. H. Salisbury & Co., Inc., exhibited their line of linemen's rubber protective devices such as rubber line hose, insulator hoods, linemen's blankets, gloves, glove protectors, glove bags, sleeves, line coats, boots, hats, insulating stools, switchboard matting, tool bags and accessory articles.

New designs in the dry channel linemen's protective devices were shown by The Surety Rubber Company. New designs in pigs, pin saddles, gloves, sleeves and blankets for linemen's use were also shown. Gloves and aprons made of synthetic rubber for use in rubber solvent chemicals were also seen.

Safety devices for handling and storing hazardous liquids of the well known "Protectoseal" quality were displayed by the Protectoseal Company.

The representatives at the Hynson, Westcott & Dunning booth were kept busy giving delegates information in connection with mercurochrome in its relation to first aid application in the industrial field.

Robert A. Bernhard exhibited a shock proof antiseptic applicator with a fountain pen feed filled with either iodine, metaphen, merthiolate, mercurochrome,

or ferric chloride for poison ivy. A new solution was introduced here for removing creosote from the skin. Mr. Bernhard also displayed the Saf-fast liquid adhesive for fastening surgical dressings.

Burroughs Wellcome & Co. made their usual interesting display of "Tabloid" first aid supplies.

To emphasize the opportunity as well as the responsibility of individuals in preventing accidents, the Metropolitan Life Insurance Company displayed literature, reports, posters and films which are available to persons interested in industrial, home, traffic, or public safety. An effort was also made to show how these may be utilized in furthering present safety programs.

Barrett-Cravens Company was back this year with an interesting display of material handling equipment. Lift trucks in many models, Steeleg platforms, portable elevators in several types were features of this well rounded out exhibit.

With the Congress in their home town, the American Air Filter Company Inc. of Louisville arranged for visiting delegates to visit their laboratories where dust tests were made and equipment was demonstrated in actual operation. In their display at the exhibit, a complete setup of a Roto-C'hone in operation, an Airmat dust arrester, a cloth dust arrester, and a complete line of filters both of the unit and automatic type were shown.

The Invincible Vacuum Cleaner Manufacturing Company displayed several models of industrial vacuum cleaning equipment for cleaning all types of factory floors, walls, ceilings, overhead surfaces and parts of machinery.

Something entirely new in an exhibit was made by the Sleepsafe Industries, Inc. Even though we agree with Mark Twain that most people die in bed, their

(Please turn to page 62)

# THE SAFETY EXCHANGE

"A ROUND TABLE IN PRINT"

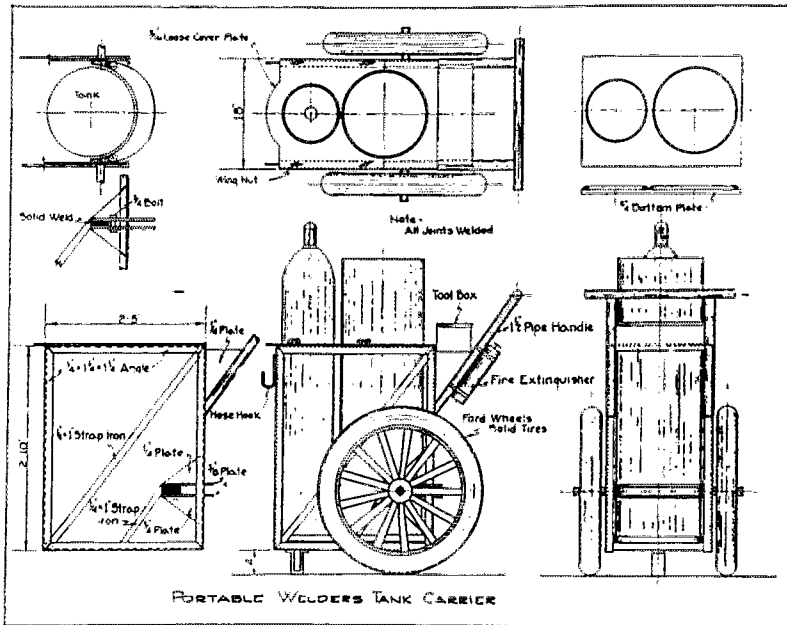

## Portable Tank Carrier for the Welder

This carrier was designed in the Warner plant of the American Cyanamid Company for Pyrofax and oxygen tanks. One designed for acetylene and oxygen tanks could be made 6 inches to 8 inches narrower. The advantages of this carrier are:

1. Ease in getting through doors and narrow aisles.
2. Ease and safety of transportation.
3. Safety in changing tanks.

## Questionnaires Teach Safety Lessons

Safety education in the Whiting plant of the Standard Oil Company (Indiana) is aided by the use of a series of questionnaires. The questions relate to various operating practices. They are short and comparatively simple. Employees are given plenty of time to fill in the answers; a week or ten days may be allowed as writing is a laborious task for some workmen. The answers need not be worked out individually; in fact, employees are encouraged to discuss the questions with each other.

4. Low construction cost.
5. No danger of tanks being upset.

It is made of scrap material, principally angle iron, and steel. Of welded construction throughout, the only nuts used are the four wing nuts to hold cover plate on frame and the two axle nuts. The wheels are those from any of the lighter automobiles; the tires are solid. A tool box and fire extinguisher are also carried. A blue-print of this carrier is available in the library of the National Safety Council.

While it is not compulsory to turn in the papers, there are very few employees who fail to do so. The papers are then corrected and returned to the employees. Copies of these questionnaires may be borrowed from the National Safety Council library.

## They Think of Safety When the Whistle Blows

To remind every employee of the need for safety the Reynolds Wire Company, Dixon, Ill., once each shift blows a whistle for twenty seconds. All workers

The ideas presented here have proved helpful. If you have developed some useful device or method send in a description, with illustration, if possible. These devices are home-made and are not available commercially

are required to stop work at the signal and face east. The company believes that this reminder, in use for several years, has been an effective means of promoting safety.

## Soldering Outfit Is Simple and Safe

This safe and handy soldering outfit, mounted on a steel plate, consists of a burner, holder for salts, and rack for

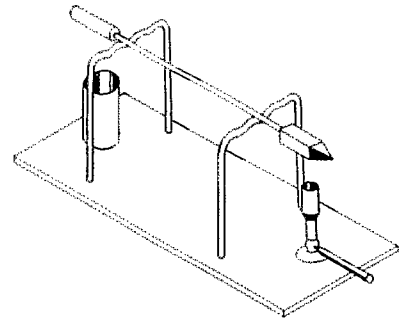

the iron. There is a definite place for tools and equipment, and the chance of burns due to hot irons is greatly reduced.

## Removing Broken Light Bulbs

To avoid the hazards of removing the screw end of a broken light bulb with fingers or pliers, press an ordinary cork firmly into the base of the bulb and unscrew the bulb safely and easily. This method was described by L. Kasper, of Philadelphia, in *Popular Mechanics*.

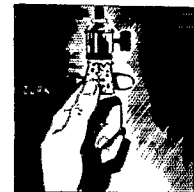

NATIONAL SAFETY NEWS

# Award 120 Trophies in No-Injury Contests

ONE hundred twenty bronze plaques and 74 certificates were awarded at the Twenty-Fourth Annual Safety Congress last month at Louisville to winners and runners-up in seven major contests conducted by the National Safety Council.

One hundred and four of the plaques and 46 of the certificates were awarded in the six industrial contests conducted by the Marine, Metals, Paper and Pulp, Petroleum, Public Utilities and Rubber sections. In these contests 773 industrial units, employing 780,000 workers, and working a total of 1,187,087,000 man-hours, competed.

The remaining sixteen plaques and 28 certificates were awarded in the National Fleet Safety Contest, conducted by the Vehicle Fleet section. In this contest 500 fleets, operating 33,000 vehicles which traveled 561,000,000 miles, participated. Details on the awards in the seven contests follow. All of the contests ran for a year terminating on June 30, 1935, with the exception of the Marine, Petroleum and Rubber contests, which were conducted from January 1 to June 30, 1935.

## Marine Section

In this, the fourth annual contest of the Marine section 85 units, entered by 29 members of the National Safety Council, competed. In all, 63,528 persons who worked 66,965,397 man-hours were active participants. The average frequency rate for this year's contest was 12.977, which was a fourteen per cent increase from the 1934 rate of 11.338. In the 1935 contest 43 units ended with a frequency rate below the average. Ten units had perfect records.

Eleven plaques and eight certificates were awarded, the plaques being presented to the following:

### LINERS DIVISION

Lykes Dixie Mediterranean Line, New Orleans, La. 182,312 hours, no injuries.

### TANKERS DIVISION

Lago Shipping Co., Aruba, N.W.I. 751,240 hours, 2 injuries.

### HARBOR EQUIPMENT DIVISION

Atlantic Coast Line Railroad Co., Terminals, Norfolk, Va. 168,929 hours, no injuries.

Associated Oil Co., Harbor Equip. Div., San Francisco, Calif. 103,616 hours, no injuries.

Atlantic Coast Line Railroad Co., Terminals, Port Tampa, Fla. 38,095 hours, no injuries.

### STEVEDORING DIVISION

Lykes Bros.—Ripley Steamship Co., Tampa, Fla. 8,706 hours, no injuries.

### SHIPBUILDING & REPAIR DIVISION, GROUP A

U. S. Navy Dept., Philadelphia Navy Yard, Philadelphia, Pa. 3,823,767 hours, 2 injuries.

### GROUP B

The New York Central Railroad Co., New York, N. Y. 108,770 hours, no injuries.

U. S. Engineer Dept., Great Lakes Div., Cleveland, O. 105,757 hours, no injuries.

The New York, New Haven & Hartford R.R. Co., New Haven, Conn. 73,248 hours, no injuries.

U. S. Engineer Dept., South Atlantic Div., Norfolk, Va. 56,360 hours, no injuries.

## Metals Section

One hundred and ninety-four units were entered in the Metals Section contest this year. Two hundred nineteen thousand eight hundred thirty employees worked 425,051,091 man-hours. The average frequency rate was 8.354, which represents a decrease of 19 per cent from the rate of the 1934 contest. This year 104 units ended with a frequency rate below the average. Twelve per cent of those completing the contest finished with perfect records. In this contest 25 plaques and seven certificates were awarded, the plaques going to the following:

### STEEL MILLS DIVISION, GROUP A

The Corrigan McKinney Steel Co., Cleveland, Ohio. 6,566,016 hours, 10 injuries.

### GROUP B & C

The Youngstown Sheet & Tube Co., South Chicago, Ill. 929,672 hours, no injuries.

Great Lakes Steel Corp., Hanna Furnace Division, Ecorse, Mich. 783,302 hours, no injuries.

The Youngstown Sheet & Tube Co., Hubbard Furnaces, Youngstown, O. 104,325 hours, no injuries.

### ROLLING, FINISHING & FABRICATING DIVISION, GROUP A

Aluminum Co. of Canada, Ltd., Toronto, Ont., Canada. 1,236,706 hours, 2 injuries.

### GROUP B

Revere Copper and Brass, Inc., Baltimore Division, Baltimore, Md. 900,413 hours, no injuries.

The Youngstown Sheet & Tube Co., Evans-ton, Ill. 536,856 hours, no injuries.

Republic Steel Corp., Grand Crossing, Ill. 334,969 hours, no injuries.

Lehigh Structural Steel Co., Allentown, Pa. 279,050 hours, no injuries.

Steel & Tubes, Inc., Brooklyn, N. Y. 251,847 hours, no injuries.

Chapman Price Steel Co., Indianapolis, Ind. 225,116 hours, no injuries.

Laclede Tube Co., Alton, Ill. 139,917 hours, no injuries.

Republic Steel Corp., Unionville, Conn. 126,936 hours, no injuries.

### FOUNDRIES DIVISION

Mackintosh-Hemphill Co., Midland, Pa. 339,385 hours, no injuries.

The American Rolling Mill Co., Central Works, Middletown, O. 181,809 hours, no injuries.

Ideal Foundry & Machine Co., Youngstown, O. 153,577 hours, no injuries.

The American Rolling Mill Co., Sixth St. Foundry, Ashland, Ky. 104,022 hours, no injuries.

### HEAVY MACHINE SHOPS DIVISION, GROUP A

United Shoe Machinery Corp., Beverly, Mass. 6,246,912 hours, 3 injuries.

### GROUP B

United States Rubber Products, Inc. Shoe Hardware Div., Waterbury, Conn. 808,123 hours, no injuries.

C. Hager & Sons Hinge Manufacturing Co., St. Louis, Mo. 570,669 hours, no injuries.

D & B Pump & Supply Co., Los Angeles, Calif. 180,587 hours, no injuries.

Noera Manufacturing Co., Waterbury, Conn. 163,485 hours, no injuries.

Pittsburgh Steel Co., National Steel Fabric Div., Monessen, Pa. 125,390 hours, no injuries.

### LIGHT MACHINE SHOPS DIVISION

Benjamin Electric Manufacturing Co., Des Plaines, Ill. 307,091 hours, no injuries.

Boston Gear Works, Inc., No. Quincy, Mass. 634,820 hours, no injuries.

## Paper and Pulp Section

One hundred and ten mills competed in the Paper and Pulp Section contest this year. These mills employed 42,378 men who worked 86,867,184 man-hours. The average frequency rate was 16.566, a decrease from the average frequency of 19.626 of last year. Twelve mills had perfect records. In this contest twelve plaques were awarded and six certificates, the plaques to the following:

### DIVISION I, GROUP A

Hollingsworth & Whitney Co., Algonquin & Taconnet Mill, Waterville, Maine. 2,419,350 hours, 11 injuries.

### GROUP B

St. Croix Paper Co., Woodland, Maine. 785,793 hours, no injuries.

### GROUP C

International Paper Co., Little Island, N. Tonawanda, N. Y. 548,504 hours, 1 injury.

### GROUP D

Bird & Son, Inc., Phillipsdale, R. I. 216,581 hours, no injuries.

United States Envelope Co., Morgan Paper Co. Div., Lititz, Pa. 184,863 hours, no injuries.

International Paper Co., Livermore Mill, Chisholm, Maine. 158,610 hours, no injuries.

Spaulding Fibre Co., Inc., New Mill Plant, Milton, N. H. 125,879 hours, no injuries.

(Please turn to page 56)

# Traffic Is Industry's Problem, Too

By I. L. GILBERT

*Division Plant Employment Supervisor, Michigan Bell  
Telephone Company, Detroit, Mich.*

Industry is recognizing its part in the problem of community safety, and industry is also doing something about it

**W**HEN we consider that our traffic problem is comparatively new, and that the automobile has come upon the scene within the lives of many of us, we do not wonder so much that we failed to curb its destruction. Twenty years ago the dangers of traffic were not realized. It is only within the last few years that a comparatively few people began to appreciate the enormity of the problem and began to work toward its solution through laws covering the examination and licensing of drivers, financial responsibility, the construction of safer highways, the instruction of children in our public schools and of adults who drive.

What has already been done? The National Safety Council has done much to disseminate information and arouse interest nationally through printed literature and through its great annual congresses. Community safety organizations have aided with their programs of group meetings for safety engineers, supervisors and the public; their publicity material through the press and over radio, and their valuable stimulation to work through contests and first-aid instruction.

Has all this done any good?

The irrefutable fact that the commercial driver who has been reached by these methods has had a decrease in his accident rate, while the rate for the private motorist has increased, proves that good has been accomplished. Progressive police departments have also aided in decreasing accident rates where they have tackled the job with courage and common sense.

Of course, the courts must work hand in hand with the police if the efforts of the latter are to bear fruit. A police

department which conducts a worthwhile educational program and patrols the streets firmly but courteously will do much to stop accidents, as has been proved in Evanston, Illinois, and Rochester, New York, and other cities. Where people are sufficiently progressive to require a periodic check of mechanical equipment we can look for a still better accident rate. The public schools through their training of their pupils and the establishment of safety patrol leaders in conjunction with the police have shown that it is possible to reduce accidents materially. The insurance companies, in instructing their clients and furnishing posters, have done a worthy part in reducing traffic toll.

## We Are the Community

Now, why should industry take a part in this community traffic problem? Who is it that composes the community? Why, you and I and our friends and neighbors, the large majority of whom drive autos and who therefore object generally to laws which limit us but would welcome laws to limit the other fellow. This is why it is so hard to arouse public interest and to bring effective pressure to bear. Industry too, is a vital part of the community. The people in the community earn their livelihood in serving industry. Anything that imperils their safety or their usefulness will harm industry. Industry pays a large share in the upkeep of any community through taxes. So industry by its very nature has a selfish interest in each community. But over and above this, most industrial concerns take an active pride in their communities.

What has industry already done and what remains to be done? First and foremost as industry's contribution,

stands its record of a continual lowering of the commercial drivers' accident rate. The automotive industry has kept far ahead in the design of mechanical safety factors in the cars themselves, until today, with four-wheel brakes, steel bodies, and shatter proof glass, and other factors of safety, mechanical defects are responsible for less than 15 per cent of all motor car accidents.

Inasmuch as the larger industrial concerns each employ a number of drivers, it stands to reason that industry has concentrated more on the problem of preventing motor vehicle accidents than any other group. This record of improvement has been accomplished by safety rallies, posters, competition among companies, and within companies on accident prevention, by offering bonuses, by giving safe driving awards, by thorough inspection of cars, by training each driver in the proper operation and care of his car, by competent medical examination, by traffic courts conducted by supervisors to determine causes of accidents and to prevent similar occurrences, by fair but stern discipline of drivers, by having a supervisor caution each driver on leaving the garage, especially when road conditions are more hazardous than usual, by having a specially trained supervisor examine each driver before permitting him to handle a car, by giving each driver the American Red Cross training in first aid, by impressing on the supervisors that the safe operation of each motor vehicle by his men was the supervisor's responsibility, by periodic check up on drivers with questionnaires.

Let me tell you what happened in our own company back in 1929 and 1930. During this period metropolitan Detroit was breaking all records for traffic accidents, and frantic efforts were being made to abate the slaughter. We called together a committee of our drivers and

*(Please turn to page 64)*

NATIONAL SAFETY NEWS

# INDUSTRIAL HEALTH

A Non-Technical Symposium for Physicians and Laymen

## Preventing Tuberculosis Among Employees

By CHARLES S. GALLAHER, M. D.  
*Eastman Kodak Company, Rochester, N. Y.*

**T**HE prevention of tuberculosis in industry is one of the many problems confronting the industrial physician. It is well to appreciate that the disease is present among all classes of people and is fairly frequent. Its incidence among industrial employees is approximately two per cent.

An analysis of 100 cases of tuberculosis occurring among employees of the Eastman Kodak Company by Dr. W. A. Sawyer and Dr. E. K. Richard showed some interesting facts. It was noted that the mortality among women between the ages of 20 to 29 was 109 deaths per 100,000, or about what it was 14 years ago. The death rate among men was 74 per 100,000. In spite of the fact that the mortality rate has been dropping during the past 35 years, tuberculosis is the second greatest cause of death among males, being exceeded only by heart disease.

Two other interesting points were brought out in this study. The first was that the average age of the patient at the time of diagnosis was 31 years. Such an ailment coming at the crucial time in life, when young persons are getting established in their occupations, results in a real economic catastrophe.

The second point showed the cost of an average case of tuberculosis to be \$4,062, with a possible maximum of \$24,000. Of the first figure, 80 per cent is accounted for by lost wages and sick benefits paid. The remaining 20 per cent represents the cost of medical care. These figures can be more readily appreciated when we find that the average lost time was 542 working days for female patients and 648 for males, an average of over two years in actual working days.

NOVEMBER, 1935

To prevent tuberculosis, we must first discover the case. The work is carried on by three departments, namely: employment, medical, and safety.

The employment department's duty is to select the proper applicants for the various types of work. The department is assisted by recommendations from the medical department.

The medical department is really the fountain head of prevention work. It is its duty to discover, and dispose of each case, properly. In doing this work, there are two classes to consider: the applicant and the older employee. When the applicant comes to the employment department, he is given a requisition slip for physical examination. Upon presentation of this slip to the medical department, a medical history is taken, which is followed by a clinical examination, Wasserman, urinalysis, and a chest x-ray.

We have become convinced that the only way to find the majority of tuberculosis cases, is to have a satisfactory x-ray, otherwise, cases of so-called "silent tuberculosis" are apt to escape the most careful examiner.

Upon completion of this examination, if the applicant is satisfactory, he is accepted for employment, and subjected only to routine health examinations at intervals.

### Three Types of Cases

Applicants who have tuberculosis, are divided into three classes: active cases, stabilized adult cases, and juvenile cases.

The active cases are, of course, rejected for employment. They are referred back to their family physician with the x-rays, or referred to the local

sanitarium, and local health bureau is informed so that the follow-up of each case may be obtained and examinations made.

If the case is deemed to be stabilized, but shows a moderate or marked fibrosis, the applicant is still rejected. This is due to bad experience with this type of case. We find that all too frequently stabilized cases reactivate and become industrial hazards.

The applicant is occasionally passed for particular kinds of work when he has minimal pulmonary fibrosis that is very definitely stabilized. This employee is examined routinely each year and given a chest x-ray, which is kept for comparison with all other previous x-rays, in order to avoid passing up cases of very low activity.

Cases of juvenile tuberculosis are usually passed, and if listed as tuberculosis suspects, are periodically examined and x-rayed. Individuals having suspicious chests are so advised, and instructed in protective measures. Suspicious cases are never placed on hazardous work.

Older employees are given periodic examinations. If normal, they are called in at intervals every two or three years in one plant and yearly in others. If they have tuberculosis they fall into one of two classes: inactive or active. The inactive cases are examined and x-rayed at intervals of six months to one year to determine if any activity has developed.

The active cases fall into two groups as follows:

1. The quite active case who is being incapacitated by the condition. If the proper treatment can not be given at home, he is encouraged to go into the local sanitarium for treatment, and when totally and permanently disabled, is given retirement. Frequently, however, he is able to overcome the disease by proper treatment, and ultimately returns to work. He is then given light work which the attending physician is convinced he can do without injuring him-

(Please turn to page 48)

# SAFETY INSTRUCTION CARDS

## A List of Cards Issued to Date

**T**HESE cards are intended for individual distribution. They may be carried in the pocket conveniently; they will slide into most pay envelopes easily. If tacked on the wall over a work bench or machine they will not tear off when a little wind strikes them; several of them can be displayed in a small space and they will fit in a standard card file.

The following alphabetical index of Safety Instruction Cards issued to date has been prepared to aid members in ordering cards which apply to their own particular operations.

Subject	No.
Acid and caustic pipe lines, opening flanged joints	117
Acid, sulphuric—handling	242
Acid tanks, repairing	124
Cleaning out large tanks	293
Air hoist operation	142
Aprons, protective	228
Artificial respiration	165
Auto tires, inflation	208
Axe, how to handle	191
Babbitt, pouring	139
Belt, to put on a pulley	8
Removing from pulley	193
Bicycles	241
Boiler gage glasses, replacing	103
Boxes and crates, shipping	206
Bricks, how to pile	242
Broken glass, how to dispose of	244
Cable Clamps	36
Carboys, safe handling	195, 224
Carpenters	127
Carrying long materials on shoulders	39
Case hardening with cyanide	133
Chain links, hooks, castings—detecting flaws in	3
Chains, safe loads for	63
Determining need for annealing or normalizing	267
Safe use of	161
Chemical laboratory practices	207
Chemicals, protection against	42
Cleaning machine parts	137
Clothing for machinists	230
For cold weather	269
For men	83
For women	84
Cold chisel, cutter or punch head, proper shape for	28
Compressed air—practical jokes	287
Couplings, link and pin	46
Crane and hoist operators, advice to	58
Crane Signals	5
Cranes, locomotive (steam driven)	295
Crushed hands, avoiding	53
Dog Bites, to avoid	175
Drill press operators	87
Driving long rods	21
Driving vehicles, attention to driving	209
Backing	198
Braking distances	216
Checking before starting	225
Choosing routes	251
Courtesy in driving	275
General suggestions	170
Parking	235
Setting out flares	232
Speed control	186
Stopping on highway at night	260
What to do in case of accident	183
Drums, handling	44, 132
Dust explosions, preventive measures	239

Safety Instruction Cards are printed on white card stock, 3 by 5 inches, slightly heavier than government postcards. In any quantity the price is one cent per card (all of one kind or selection) with a minimum order of 25 cents. Stamps or cash may be sent with order, or an invoice will be rendered.

The order should specify "Safety Instruction Cards," and give the numbers of the cards selected.

Electric arc welding	68
Electric line work, safety lines	96
Electric motors, starting	60
Electric wires, safe carrying capacity	13
Electricians	128
Elevators, inspection and repair	104
Advice to operators	41
Freight elevator inspection	271
Eyes, care of	113
Eye protection, making goggles comfortable	162
Keeping goggle lenses clean	245
Explosives, storage	118
Opening dynamite case	157
Preparing blast with cap and fuse	294
Explosive vapor, removing from drum	171
Extension cord, fastening plug to	26
Falling objects	163
Falls, general	161
Things to look out for	185
Files	174
Fire, to put out clothing	23
What to do in case of	122
Fire extinguisher, soda acid	17
One-quart pump type	18
Checking for winter	264
Fire fighting, electrical hazards	247
Fire prevention, inspection check list	237
First Aid, acid and caustic burns	75
Artificial respiration	165
Burns	196
Carbon Monoxide	115
Emergency stretchers	252
Fractures	211
Frost bite	145
Minor injuries	233
Simple tourniquet	73
Transporting a patient	173, 261, 273
Where to apply pressure to stop bleeding	149
Flammable liquids, storing	226
Flash points	265
Fumigating with cyanides	217
Fuses, removing and replacing	274
Garage mechanics	82
Gas leaks	180
Gas masks, identification of canisters	212
To test for air-tight fit	87
Gas welding—cylinders	99
Gas and oil furnaces, lighting burners	166
Gases, explosive ranges	290
Gasoline blow torches	76
Gasoline engines, cranking	190
Going to and from work	158
Grinding wheels, to check peripheral speeds	10
Grinding wheels, mounting on spindles	50
Flange dimensions	59, 66, 81
Safe operation	102
Making ring test	103

Guards, use of	150
Hair, protection	238
Hammer heads, fitting to handles	6
Hammer hints	31
Hand protection, discs for	33
Hand saw, how to start	123
Hand tools	35
Sharpening	192
Hand truck, two-wheel	126
Four-wheel push truck	156
Health, general suggestions	141
Colds	125
Headaches	162
Vacation hints	221
Heat exhaustion	57, 197
Home hazards	129
Hooks, hand	71
Horse, a well designed	2
Horses, suggestions for handling	172
Horseplay	154
Hours of danger	256
Housekeeping, inspection list	29
Salvaging materials	179
Ice	121
Ice slipping hazards	107
Ice tongs	236
Inattention	177
Jacks, safe use of	93
Janitors, sweepers and cleaners	134
Kite flying	40
Knives	144
Knot, underwriters	9
Knuckle guards for trucks and wheelbarrows	248
Ladders, safe angles for	16
Carrying	202
Climbing	51
Extension	178
Step ladders	262
Lathe, all-purpose metal-working	39
Lead poisoning, protection	116
Lifting—safe methods	55
Linemen, care of leather equipment	288
Linemen's climbers, to sharpen	22
Live wires, to free person from	189
Manila rope	72
Care when not in use	14
Care of	106, 203
Testing in the field	231
Maintenance and repair men	79, 259
Safe clothing	253
Making safety suggestions	109
Masons, brick	135
Stone	220
Matches	182
Monkey wrenches	204
Motormen and conductors	48
Nails, how to start	153
New employees, helping	101
Nitrous fumes	219
Office accident causes	77
Oil storage tanks, cleaning	70
Oilers, advice to	74
Oiling machinery	147
Painters, brush—lead poisoning	289
Pens and pencils	272
Personal safety check list	181
Picks	176
Piling materials, general	140
Bags of cement	249
In process near machines	266
Pipe fitters	215
Pipe lines, blanking off	100
Pipe wrench, safe use of	188
Piping systems, identification of	20
Pneumatic hammers and chisels	52
Poison ivy	30
Poison oak and poison sumac	64

(Please turn to page 68)

NATIONAL SAFETY NEWS

# THE ACCIDENT BAROMETER

Prepared by the Statistical Bureau, National Safety Council

ACCIDENTAL DEATHS OF ALL TYPES showed a small decrease in August compared with August, 1934. The reduction was from 9,100 to 8,800, according to present reports. Both home and occupational fatalities decreased substantially, but this improvement was largely offset by increases in motor vehicle and other public accidental deaths. With the addition of the August estimate the eight months' total is at present set at 63,930, compared with 67,160 last year. This is a reduction of 4.8 per cent.

OCCUPATIONAL ACCIDENTAL DEATHS resulted in approximately 1,200 deaths during August. This compares favorably with the August, 1934 total of 1,300. The January-August total is now placed at 10,800, or approximately the same number estimated for the first eight months of last year. In the inter-plant contests of community safety councils the average August frequency rate per million man-hours was 10.85, a drop of 17 per cent from last year's comparable rate of 13.08. The severity rate per thousand man-hours also decreased from 1.11 to 0.95. During the eight months of this year frequency has averaged 13.28 compared with 14.92 for last year, and severity stood at 0.86 against 1.14 last year. In three sectional contests conducted by the National Safety Council the August frequency rate was 8.86 compared with 10.29 last year and the eight months' rate was 8.71 or 15 per cent under last year's comparable rate. September reports of Industrial Commissions indicate a 21 per cent increase in deaths from September, 1934.

COAL MINE FATALITIES in August numbered 74 or 2.59 deaths per million tons of coal produced, according to U. S. Bureau of Mines reports. For bituminous mines only the rate was 2.46, or 10 per cent lower than the August, 1934 rate of 2.88. For anthracite mines the rate stood at 3.86, or 8 per cent below last year's August rate of 4.19. Furthermore, both kinds of mines had substantial decreases from July this year. The seven months' rates were: bituminous 2.44; anthracite, 5.52. This represents a decrease from the same period last year of 3 per cent for bituminous mines, but an increase of 25 per cent for anthracite mines.

NOVEMBER, 1935

## All Accidental Deaths

January-August

1935	63,930
1934	67,160
1933	58,515

U. S. Census Bureau total for 1933;  
National Safety Council estimates  
for 1934 and 1935.

STEAM RAILROAD DEATHS in June numbered 450, an increase of 6 per cent over the total for June, 1934. Almost half the increase was due to more grade crossing fatalities, which rose from 89 to 100. Trespasser deaths went up from 277 to 288, and employee fatalities from 37 to 46. In contrast, all but one class of persons showed decreases in injuries and the total dropped over 15 per cent to 2,155. The first six months of the year, together, show a small increase in deaths (2,233 to 2,270), but a sizeable decrease in injuries (13,819 to 13,371). Most of the advance in fatalities was among trespassers. Most of the drop in injuries is credited to non-trespassers.

MOTOR VEHICLE DEATHS in August were 3.7 per cent more numerous than in the same month last year. This is the fourth month in which fatalities have been above 1934. The other three are: February (up 1.3 per cent), March (up 16.4 per cent), and April (up 1.5 per cent). Furthermore, the records show that in February, April and August cities continued to show a decrease from last year, thus indicating that the rural accident situation is becoming relatively

These items summarize briefly the monthly reports collected by the National Safety Council to show current accident trends. Certain of these reports are analyzed more fully in other monthly publications of the Council, devoted to industrial, traffic, commercial vehicle, home, and school safety. In addition to these monthly data, the Council's annual statistical report "Accident Facts," contains very detailed information on all types of accidents.

more unfavorable. The eight months' total of motor vehicle deaths is estimated to be 21,600, or the same number that occurred in the same months of 1934.

COMMERCIAL VEHICLE ACCIDENTS numbered 1.60 per 100,000 vehicle miles during August, among fleets entered in the National Fleet Safety Contest. The comparable rate for August, 1934 was 1.84. During the first two months of the present Contest the rate was 1.66, a reduction of 12 per cent from last year's July-August rate of 1.88. All types of vehicles shared in the decrease: buses, from 1.45 to 1.12; passenger cars, from 1.26 to 1.12; and trucks, from 2.70 to 2.53.

PUBLIC (NOT MOTOR VEHICLE) DEATHS totaled approximately 2,000 in August. This is an increase of 17.7 per cent over last year's August total of 1,700. According to present reports, this advance comes chiefly from more drownings. Deaths in steam railroad accidents (not involving motor vehicles) were considerably fewer than last year and there was a small reduction in falls. Other types were not sufficiently numerous to have much influence on the total. The January-August total is estimated to be 12,100, a decrease of 3.2 per cent from last year's comparable figure of 12,500.

ACCIDENTAL DEATHS AT HOME totaled about 2,700 in August, a welcome reduction of 18.2 per cent, from the August, 1934 figure of 3,300. This decrease can be largely attributed to the absence of any great number of excessive heat fatalities. Last year, it will be recalled, the heat wave extended into August and was responsible for a considerable number of deaths during the first two weeks. With the addition of this favorable August figure the eight months' total now stands at 21,300, compared with 24,200 for the same months of 1934.

LOOKING AHEAD . . . . Accidental deaths in November will number about the same as in October—which means that the total will be one of the year's largest. Motor vehicle fatalities will probably decrease slightly, but traffic will drop even more, showing the situation to be fundamentally worse than in October. Deaths from burns will increase, probably as much as 40 per cent. Drownings, already at a low point, are likely to decrease to around 250.

# Hydrogen Sulphide

## Industrial Data Sheet D-Chem. 16

### A. Problem

1. What are the hazards of hydrogen sulphide, and what precautions should be taken against those hazards?

### B. Hazards

2. The principal hazard is poisoning by inhalation.

### C. Discussion

3. Hydrogen sulphide (sulphureted hydrogen or rotten gas) is a highly toxic, colorless gas heavier than air, with the odor of rotten eggs. It burns with a blue flame and produces sulphur dioxide, a very irritating gas with a pungent odor. It forms explosive mixtures with air, the lower limit of complete flammability being 5.9 per cent, hydrogen sulphide, and the upper limit, 27.2 per cent. It is soluble in water but becomes less soluble as the temperature of the water increases. It is most frequently encountered in the production and refining of

high-sulphur petroleum; in the natural gases; in gypsum and sulphur mining; in rock strata and underground water (where it is encountered in tunneling and caisson work); in blasting with black powder; in blasting high-sulphide ores with other explosives; in gas manufacture; in the carbonization of coal; and in the manufacture of artificial silk and chemicals. It is also found in the atmosphere of sewers, cesspools and in the products of putrefaction.

4. The sense of smell cannot be depended upon to detect hydrogen sulphide for two reasons: first, the sense of smell is lost in two to fifteen minutes of exposure to concentrations as low as 0.010 to 0.015 per cent volume of the gas; second, exposure to higher concentrations for less than a minute dulls the sense of smell and may result fatally. There are a number of qualitative tests which will indicate the pres-

ence of the gas; one such test is the darkening of paper soaked in lead acetate. However, for an accurate determination of the presence of the gas as well as of its percentage in the air, a detector approved by the United States Bureau of Mines or a method of test recommended by that Bureau, should be used. (See Note W)

### Symptoms

5. The susceptibility varies according to the individual but appears to be increased by previous exposure. Acquired immunity has never been observed, and the gas has no cumulative effects. The poisoning may be either sub-acute or acute. Sub-acute poisoning consists of the irritant action of the gas on exposed tissues and mucous membranes producing conjunctivitis and respiratory distress. Acute poisoning (strangling) may

(Please turn to page 74)

TABLE A—TOXICITY OF HYDROGEN SULPHIDE TO MEN

H <sub>2</sub> S Per Cent	0-2 Minutes	2-15 Minutes	15-30 Minutes	30 Min.- 1 Hour	1-4 Hours	4-8 Hours	8-48 Hours
0.005 0.010				Mild conjunctivitis; respiratory tract irritation.			
0.010 .015		Coughing; irritation of eyes; loss of sense of smell.	Disturbed respiration; pain in eyes; sleepiness.	Throat irritation.	Salivation and mucous discharge; sharp pain in eyes; coughing.	Increased symptoms.*	Hemorrhage and death.*
0.015 .020		Loss of sense of smell.	Throat and eye irritation.	Throat and eye irritation.	Difficult breathing; blurred vision; light shy.	Serious irritating effects.	Hemorrhage and death.*
0.025 .035		Irritation of eyes; loss of sense of smell.	Irritation of eyes.	Painful secretion of tears; weariness.	Light shy; nasal catarrh; pain in eyes; difficult breathing; conjunctivitis.	Hemorrhage and death.*	
0.035 .045		Irritation of eyes; loss of sense of smell.	Difficult respiration; coughing; irritation of eyes.	Increased irritation of eyes and nasal tract; dull pain in head; weariness; light shy.	Dizziness; weakness; increased irritation; death.	Death.*	
0.050 .060	Coughing; collapse and unconsciousness.*	Respiratory disturbances; irritation of eyes; collapse.*	Serious eye irritation; light shy; palpitation of heart; a few cases of death.*	Severe pain in eyes and head; dizziness; trembling of extremities; great weakness & death.*			
0.060 .070 .080 .10 .15	Collapse;* unconsciousness;* death.	Collapse;* unconsciousness;* death.*					

\*Data secured from experiments on dogs which have a susceptibility similar to men.

# Mercurochrome in Industry

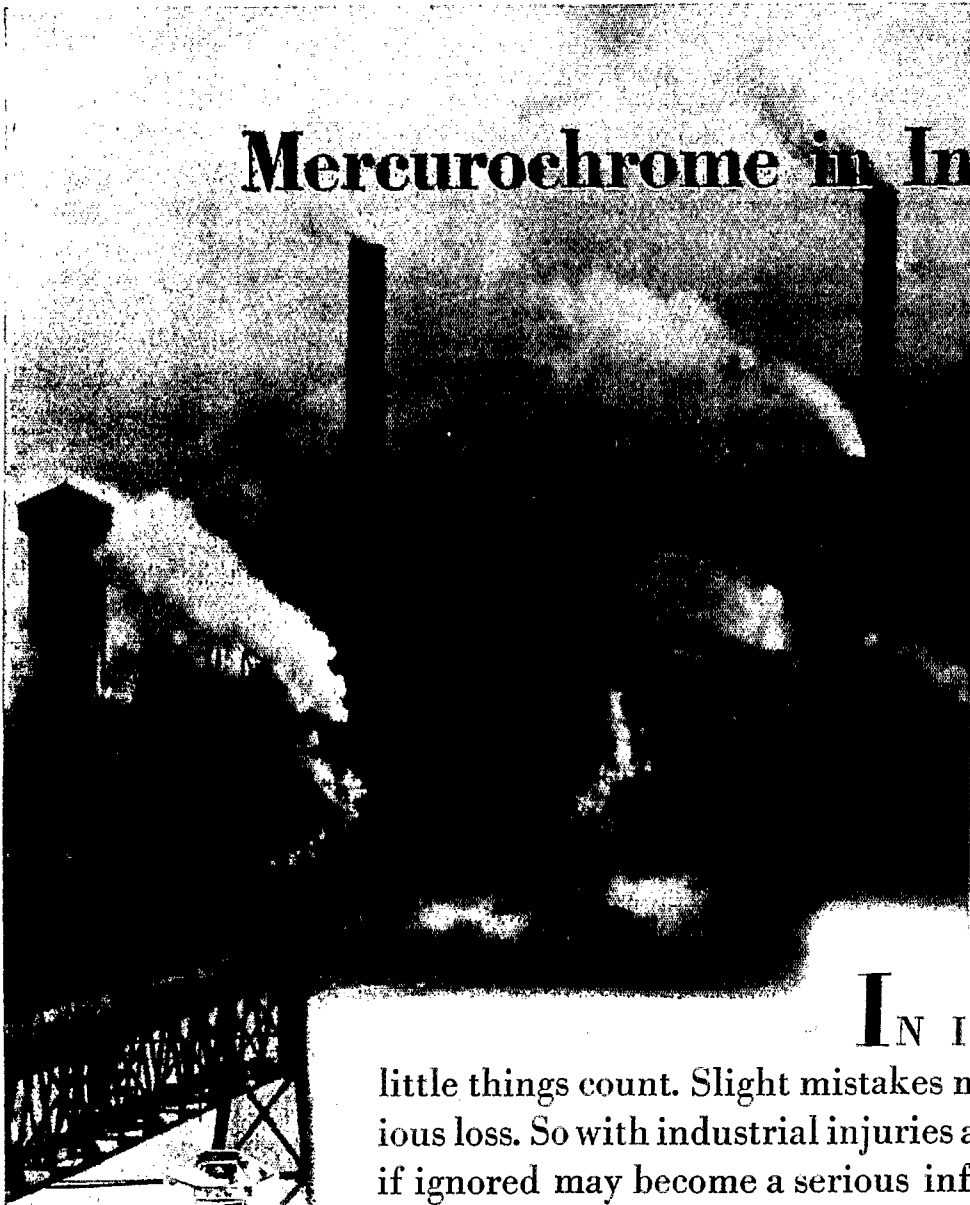

**I**N INDUSTRY little things count. Slight mistakes may mean serious loss. So with industrial injuries a little scratch if ignored may become a serious infection. ¶The first defense against infection is thorough cleansing and the application of an effective antiseptic. All wounds, however small, should receive treatment promptly. Be prepared with Mercurochrome for the first aid care of all minor injuries. In more serious cases call a physician.



This seal denotes acceptance of Mercurochrome for New and Nonofficial Remedies by the Council on Pharmacy and Chemistry of the American Medical Association.

**HYNSON, WESTCOTT & DUNNING, Inc., Baltimore, Maryland**

NOVEMBER, 1935

# Safety Engineering Loose-Leaf Handbook



## Are You Acquainted With The Wealth of Safety Information Contained In These Pamphlets?

Members who are too busy to familiarize themselves with what services the Council has to offer will be interested in the following note:

"I am writing to tell you that I have not realized until this morning the wealth of practical, constructive material contained in the 'Safe Practices Pamphlets.' I have just spent a couple of hours looking through my recently acquired volume and I am mentally kicking myself for not having utilized more of these pamphlets as educational material for our field men. Our order for four more bound volumes which will supply each of these men is enclosed."

Every member purchasing a complete set of general Safe Practices Pamphlets may select pamphlets from the special industries series to be included with the general set at no additional cost and will also receive without further cost a copy of each completely revised or new pamphlet of the general series, as it comes from the press. The complete set of general Safe Practices Pamphlets is available at \$12.00 f.o.b. Chicago and \$6.00 for the set of Health Practices Pamphlets.

*(For members only)*

NATIONAL SAFETY COUNCIL INC.  
20 NORTH WACKER DRIVE  
CHICAGO



NATIONAL SAFETY NEWS

The following is an alphabetical list of all the pamphlets in these three series. Pamphlets in the General series are numbered from 1 to 100; all numbers with the prefix "HP" indicate pamphlets in the Health series; all others are in the Special Industries series.

Title	Number
Accident Statistics, Commercial Vehicle	D-4
Acids and Caustics	25
Bakery Operations, Safety in	F-3
Belts and Belt Guards	7
Benzol	H.P. 14
Blast Furnaces	Me-2
Boilers, Marine, Safe Operation of	Mar-2
Boilers, Steam, Construction and Equipment	49
Boilers, Steam, Safe Operation of	3
Brick Making, Safe Practices in	CP-1
Burns, Chemical, Their Nature and Treatment	Chem-3
Campaign, Industrial Safety, Planning	51
Candy, Chocolate and Cocoa Manufacture, Safety in	F-2
Carbon Monoxide	H.P. 7
Cement Mill Shops, Safe Practices in	Cem-4
Cement Mill, Raw and Finished Grinding	Cem-2
Cement Mill Yards and Railroads	Cem-6
Cement Rock Quarrying and Crushing	Cem-1
Cement, Storing, Packing and Shipping	Cem-5
Chains, Hoisting, Use and Care of	98
Chlorine, Safe Handling of	71
Chromium	H.P. 1
Clothing, Protective	16
Coal Bunker, Safe Practices in Handling	Mar-3
Coal Systems, Pulverized, Safe Operations of	97
Committees, Safety	72
Compressed Air Machinery and Equipment	47
Compressed Gases, Safe Practices in Handling	96
Construction Work, Safe Practices on	Con-1
Contests, Safety	74
Conveyors	26
Cranes, Overhead Traveling	4
Cutting Oils and Emulsions, Safe Use of	44
Driver, Commercial, Non-Traffic Hazards of	D-1
Drivers for Commercial Vehicles, Selecting	D-2
Drivers for Commercial Vehicles, Training	D-3
Drums and Barrels, Handling, Cleaning and Filling	Pet-8
Dry Cleaning and Dyeing Establishments, Safety in	L-1
Dust	H.P. 4
Electric Railway Rolling Stock, Safe Maintenance of	ER-1
Electrical Equipment in Industrial Plants	29
Elevators	15
Engine Guarding and Engine Stops	9
Engineering, A Factor in Accident Prevention	79
Excavation Work, Safety in	Con-3
Exhaust Systems	32
Exits, Fire Alarms and Fire Drills	19
Explosion Hazards, Industrial	34

Title	Number
Explosions, Commercial	28
Eye Hazards, Industrial	H.P. 6
Falls of Workers—Their Causes and Prevention	99
Fatigue, Practical Methods of Reducing	50
Fire Brigades	36
Fire Causes and Prevention	31
Fire Extinguishment	24
First Aid, Training for	33
Floors and Flooring	11
Food Preserving and Canning, Safety in	F-1
Forging and Hot Metal Stamping, Safe Practices in	35
Foundries, Cleaning and Finishing Rooms in	Me-1
Foundries, Safety in	73
Fuel Handling, Storing and Firing	46
Fume Poisoning from Nitric and Mixed Acids	Chem-2
Fumigating Ships, Hazards in	Mar-1
Gases and Vapors	H.P. 9
Gasoline Service Stations, Safety in Operation	Pet-2
Goggles	14
Grinding Wheels	13
Grounding Practices	PU-2
Guards, Machinery, Construction of	53
Handling Material (Hand and Truck)	54
Handling Material (Mechanical Equipment)	55
Health Service Policies	H.P. 12
Health Supervision in Industry	H.P. 5
Heat Treating, Safe Practices in	Au-1
Hoisting Apparatus	33
Hospitals, Safety in	CE-3
Hotels, Safety in	CE-2
Housekeeping, Industrial	45
Ice, Safe Practices in Delivery of	Ref-1
Industrial Injury Reporting System, Standard	21
Infected Wounds	H.P. 3
Injured Workers, Caring for	32
Inspections, Safety	75
Investigation of Accidents	56
Job and Newspaper Printing Establishments, Safety and Health in	FB 1
Laboratories, Chemical	60
Ladders	1
Lead	H.P. 3
Leather Tanneries, Safety in	P&T 1
Lighting, Industrial Shop	22
Lumber Yards, Commercial, Safe Practices in Operating	W-2
Macaroni Plants, Safety in	F-5
Machine Shop Machinery	39
Maintaining Interest in Safety	67
Maintenance and Repair Men, Safe Practices for	70
Mathematical Tables and Data for the Safety Engineer	78
Medium-Sized Plant, Safety in the	37
Meetings, Safety	77
Meetings, Safety, Topics for	93
Mercantile Establishments, Accident and Health Hazards	CE-1
Milk Bottling Plants, Safety in	F-4
Mine Rescue Work	M-2
Motion Pictures in Educational Work	82
Motor Block Testing, Safe Practices in	Au 2
New Employees, Teaching Safety to	85
Nursing Service in Industry	H.P. 11
Oil Field Pumper, Safety for	Pet-7
Oiling Devices and Oilers	10
Organizing a Complete Industrial Safety Program	42
Personnel and Health Work	H.P. 15
Paper and Pulp Mills	PP-1
Paper Box Manufacturing, Safety in	PP-2
Physical Defects	H.P. 13
Physical Examinations in Industry	H.P. 2
Physical Therapy in Industry	H. P. 16
Pipe Lines and Tanks as Causes of Accidents	Chem-1

Title	Number
Pipe, Safe Practices in Handling and Laying	Pet-4
Piping Systems, Identification of	38
Plans and Specifications, Checking for Safety	53
Posters, Safety and Bulletin Boards	38
Power Departments, Industrial	96
Presses, Power	13
Pressure Vessels (PT-1) (Air Receivers and Hot Water Tanks)	86
Pressure Vessels (PT-2) (Steam Jacketed Vessels, Digesters, Still)	68
Public, Protection of	PU-1
Pulling Wells, Safe Practices in	Pet-1
Radio	PS-1
Railroads in Industrial Plants	48
Rayon Manufacture, Safety in	Chem-4
Refrigeration, Mechanical	61
Respirators, Gas Masks, Hose Masks and Breathing Apparatus	64
Rod Mills	Me-4
Rope, Fiber	6
Rope, Wire	26
Rubber Industry, Compounding Materials Used in the	Ru-1
Rubber Protective Equipment, Linemen's, Testing, Care and Use of	PU-3
Rules, Safety—Their Formulation and Enforcement	30
Safety Man in Industry	84
Safety Stunts	100
Scaffolds	12
Shafting, Couplings, Pulleys, Gears, Sprockets and Chains	8
Signs, Warning—Their Use and Maintenance	81
Skin Affections	H.P. 10
Spray Coating	91
Stairs, Stairways, Inclines and Ramps	2
Starting and Stopping Devices	5
State Safety Requirements in Industry	94
Static Electricity	52
Stills, Petroleum, Safe Practices in Cleaning	Pet-6
Structural and Sheet Metal Fabrication, Safety in	Me-3
Suggestion Systems	40
Tank Cars (Gasoline), Safe Practices in Loading	Pet-3
Tanks, Storage, for Oils, Acids and Dry Materials	63
Tools, Hand	41
Tools, Hand, Portable Electrical	76
Truck Cars, Motor, Hand and Push, Use of	RR-1
Truck Driving (Sales), Safe	Pet-5
Trucks and Wheelbarrows	30
Tunnel and Caisson Work, Safety and Health in	Con-2
Vehicle Accidents, Preventing	D-5
Ventilation, Industrial	37
Warehouses and Shipping Rooms	59
Water, Drinking, Wash and Locker Rooms and Toilet Facilities	27
Welding, Gas and Electric	23
Wood Furniture Manufacture, Safety in	W-1
Woodworking Machinery	20
Yards	17

**EXTRA COPIES**

Any single pamphlet listed on this page is available to members at the following rates:

No. of Copies	Per Copy
1 to 10	25c
11 to 24	15c
25 to 49	12c
50 to 99	10c
100 to 499	9c
500 to 999	8c
1,000 to 1,999	7c
2,000 or more	6c

# THE BULLETIN BOARD

A page for those who maintain the Show Windows of Safety

Conducted by STAN KERSHAW

## Consider the Purpose of Each Poster

**M**ONTH after month the Council offers 63 different kinds of safety posters from which to make your selections. Every one of these posters is prepared for a definite purpose.

As you look over the miniature reproductions in the following pages be sure you do not miss the underlying purpose which prompted the production of each poster. Remember that all of the subjects have been scheduled to fill the needs of the members and that scrupulous measures have been taken to see that every one of them is capable of doing its job well.

These posters are by no means the product of a single mind so in no case are you being expected to make use of a pet idea or the expression of a distorted thought. Not one of them is permitted to go into production without first meeting with the approval of at least fifteen safety experts.

The method of scheduling subjects calls for the production of posters that will strike at the outstanding causes of accidents. To do otherwise would be to reduce their usefulness.

In this month's assortment there are several that may be worth special consideration either because they are out of the ordinary or because they relate to subjects of outstanding importance right now.

The new traffic poster No. 5633 - C has been produced with the permission of *The Reader's Digest*. It is a particularly timely poster because the powerful article which appeared under the heading, "—And Sudden Death," is still fresh in the minds of the millions of people who have read it. It should prove to be an effective weapon against excessive speed and careless driving.

A good companion poster in a smaller size is No. 5612. This poster appeals to the heart a little more than to the sense of fear with its wording: "The four best reasons why you should drive carefully: (1) Your own life is at stake. (2) Other lives may be in your hands.

(3) Your family needs you. (4) Your friends would miss you."

To women, poster No. 5624 should carry a particularly strong appeal with its urge to be careful lest the scar of an accidental injury destroy beauty.

Poster No. 5631-B pulls at the heart strings and should cause all who stop to read it to give serious thought to ways of preventing the suffering, hardships, and heartaches that follow serious accidents.

With the winter weather comes the hazards of sleet, snow and ice and since falls of persons rate first place in the causes of injuries, poster No. 5622 with its caption, "An icy walk—Danger for all — Make it safe — Prevent a fall," should be used as widely as possible.

With business showing signs of an upswing and more and more jobs opening, it will pay to make sure that all new employees are impressed with the fact that safety is required of them. Poster No. 5248 carries a subtle reminder that only those who will work safely are wanted—"You'd better take Jenkins. I know he's a safe worker."

If your people have succeeded in making a good safety record, you will find poster No. 5609 useful in giving them the "pat on the back" they deserve. Be sure to have it signed by the manager before posting copies of it.

Be sure to put in a large enough selection so that you will be able to change your displays frequently. Maybe once a week is often enough, but we know of places where the posters are changed daily with much better results for it not only gives the employees something new and interesting to look at every day, but also lets them know that their employer is putting real energy into the company's safety work.

## Displaying Lantern Slides on Bulletin Boards

**T**HE three-and-one-quarter by four inch glass lantern slides are not too small to be interesting when viewed without the aid of a stereopticon and indeed can be used to make up unusually interesting displays.

An electrically illuminated bulletin board fitted with a glass door-front can be easily adapted to the display of slides.

Place a piece of white cardboard against the background of the bulletin board so that the electric light will illuminate it. Now with some gummed tape, affix one or more slides to the inside of the glass directly in front of the white cardboard and if you wish to make the job more complete, take a large sheet of cardboard and fit it around the slides so as to exclude all extraneous reflected light from the white cardboard. You can even letter captions on this cardboard if you so desire.

The result will be a group of illuminated pictures that are bound to attract attention.

If you have a large assortment of slides and want to have repeated showings of them, it would be a simple matter to have a carpenter construct a rack which could be screwed to the back of the glass door frame and arranged with grooved slides into which could be slid rows of slides.

## From the Scrap Book

Bulletin board space deserves to be treated with as much skill as if it were high-priced magazine advertising space.

\* \* \*

Think of safety as a commodity and do your utmost to advertise it on your bulletin boards.

\* \* \*

Winter weather is hard on outdoor bulletin boards. Keep an eye on them and when they begin to look a little the worse for wear, have someone touch them up a bit.

\* \* \*

The National Safety Council has put into circulation an enormous quantity of safety posters. To date 53,000,000 copies of over 12,000 different designs have been used in the fight against accidents.

\* \* \*

Safety work, of course, is more than advertising, but advertising and publicity are essential to the success of any campaign to reduce accidents.

NATIONAL SAFETY NEWS

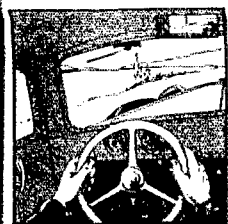

**Safety**  
*is your greatest responsibility*  
**when DRIVING**

NATIONAL SAFETY COUNCIL

Take **SAFETY**  
 Home with You



Teach Your  
 Family to  
 Prevent  
 Accidents

NATIONAL SAFETY COUNCIL

FEEL DROWSY?  
 SMELL EXHAUST GAS?

IT MAY BE  
**DEADLY  
 CARBON  
 MONOXIDE**



**OPEN** *the* **WINDOWS**

NATIONAL SAFETY COUNCIL

**A GOOD  
 SAFETY  
 RECORD**  
*is no*  
**ACCIDENT**

NATIONAL SAFETY COUNCIL



**"and  
 SUDDEN DEATH"**

NATIONAL SAFETY COUNCIL

We thank you  
 for the effort  
 you have made  
 for Safety dur-  
 ing the year.  
 May you and  
 yours enjoy  
 a happy  
 Christmas.

NATIONAL SAFETY COUNCIL



NATIONAL SAFETY COUNCIL

**Great Grief**  
 FOLLOWS  
**SERIOUS  
 ACCIDENTS**



NATIONAL SAFETY COUNCIL

The best  
**SAFETY  
 SERMON**

*is a*

**GOOD  
 EXAMPLE**

NATIONAL SAFETY COUNCIL

**NEVER  
PASS ON A HILL**

YOU COULDN'T PAY ME TO TAKE A CHANCE LIKE THAT

ME EITHER

NATIONAL SAFETY COUNCIL

If You Play The Safety Way  
You'll Have A Happy Holiday

NATIONAL SAFETY COUNCIL

**WHY!**  
MUST WE KEEP SAYING SO MUCH ABOUT SAFETY?  
**BECAUSE**  
SOME PEOPLE DON'T YET REALIZE THAT ACCIDENT PREVENTION IS GOOD FOR ALL OF US---

NATIONAL SAFETY COUNCIL

**EVER STOP TO THINK-**

How much pain and suffering you avoid by

**WORKING SAFELY?**

NATIONAL SAFETY COUNCIL

**YESTERDAY IS GONE  
TO-MORROW MAY NEVER COME  
TO-DAY IS THE DAY  
TO PREVENT  
ACCIDENTS**

TO-DAY IS THE DAY

NATIONAL SAFETY COUNCIL

**THIS MAN WILL NEVER COMPLETE HIS JOB**

**THIS ONE WILL**

**IT PAYS TO BE A SAFE WORKER**

NATIONAL SAFETY COUNCIL

**23,000**

**FALLS**

NATIONAL SAFETY COUNCIL

**IF FIRE OVERTAKES US  
YOUR JOB MAY GO UP IN SMOKE**

**PLEASE HELP PREVENT FIRE**

NATIONAL SAFETY COUNCIL

**KEEP FIT by KEEPING CLEAN**

**USE PLENTY of SOAP WATER and CLEAN TOWELS**

NATIONAL SAFETY COUNCIL

**SAFETY RULES ARE OF NO VALUE UNLESS YOU FOLLOW THEM!**

NATIONAL SAFETY COUNCIL

**BACKING**  
*about thirteen times as dangerous as any other movement a truck can make.*

**13**  
*are you*

**THIRTEEN**  
 TIMES AS CAREFUL WHEN YOU BACK UP

NATIONAL SAFETY COUNCIL

**STOP** 

see if men are working on the line before you open valve



NATIONAL SAFETY COUNCIL

**For** 

Take care lest the scar of an accidental injury mar your beauty

NATIONAL SAFETY COUNCIL

**HAND SIGNALS**

**ENGINEERS**  
 NEVER MOVE IF TRAINMAN IS OUT OF SIGHT OR YOU ARE NOT SURE OF HIS SIGNALS

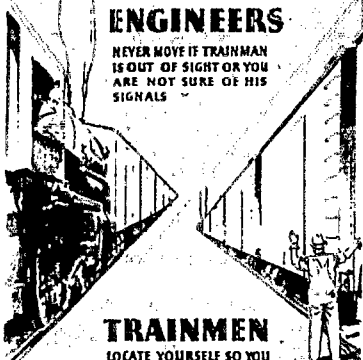

**TRAINMEN**  
 LOCATE YOURSELF SO YOU CAN BE EASILY SEEN WHEN GIVING SIGNALS AND MAKE THEM IN SUCH A MANNER AS TO BE READILY UNDERSTOOD

NATIONAL SAFETY COUNCIL



**CLEANING UP**  
*is part of the* **JOB**

NATIONAL SAFETY COUNCIL

**BROKEN RULES  
 BROKEN RUNGS  
 BROKEN BONES**



NATIONAL SAFETY COUNCIL

**THOUGHT FOR TODAY**

What would your family be doing today if you had been killed in an accident, say, a year ago.

?

NATIONAL SAFETY COUNCIL

**CONNECTING OIL HOSE**

**ENDANGERS FINGERS**  
*keep them CLEAR*



NATIONAL SAFETY COUNCIL

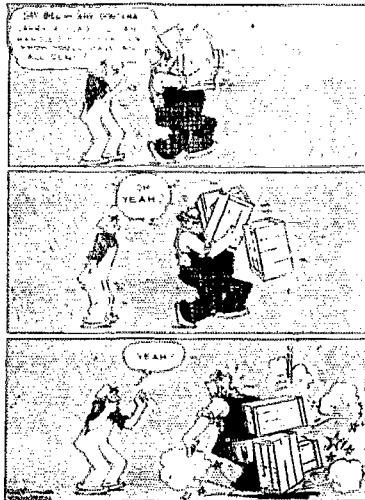

NATIONAL SAFETY COUNCIL

**ONE OF THE MOST USELESS THINGS *in THIS* WORLD *is***

**THAT PART OF A CARELESS MAN THAT HE LEAVES IN A PIECE OF MACHINERY - -**

NATIONAL SAFETY COUNCIL



One man can't do it

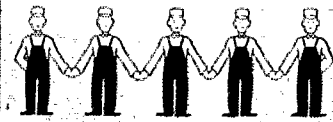

*but* **ALL OF US**  
working together can  
**STOP ACCIDENTS**

**MINERS**

*Remember this:*

It isn't always the other fellow who gets caught under a falling roof

**USE PROPS**

NATIONAL SAFETY COUNCIL

**If guards are removed~**



**whose fault is it if you get hurt?**

NATIONAL SAFETY COUNCIL

*The*  
**4 BEST REASONS**  
*why you should*  
**Drive Carefully**

1. Your own life is at stake
2. Other lives may be in your hands
3. Your family needs you
4. Your friends would miss you

NATIONAL SAFETY COUNCIL

**"WHEN THE ROLL IS CALLED UP YONDER"**



**DON'T BE THERE ON ACCOUNT OF AN ACCIDENT**

NATIONAL SAFETY COUNCIL

*your*  
**STEAM GAUGE**

**WON'T SHOW MUCH PRESSURE IF YOUR FIREBOX IS CLOGGED WITH ASHES**



**DAILY ELIMINATION IS IMPORTANT**

NATIONAL SAFETY COUNCIL



*Only*  
**A WORKBENCH**

**BUT ONE LOOK WILL TELL YOU WHAT KIND OF MAN WORKS THERE**

NATIONAL SAFETY COUNCIL



**SHORTY SEZ:**  
**TAKE**  
**NO CHANCES**  
 If you don't know  
 the safe way  
 ask the man  
 who does

NATIONAL SAFETY COUNCIL

**A B C**

**ALWAYS**  
**BE**  
**CAREFUL**

NATIONAL SAFETY COUNCIL

**Do you ...**  
 DEPEND ON LUCK  
 TO PULL YOU THROUGH  
 OR ... Do You  
 STAY OUT OF  
 TIGHT PLACES

NATIONAL SAFETY COUNCIL

**HORSE-PLAY**  
 IS THE  
 ENEMY  
 OF  
**SAFETY**  
**NO PLACE FOR HORSE-PLAY**  
**HERE**

NATIONAL SAFETY COUNCIL

**TEST ALL SCAFFOLD**  
**PLANKS BEFORE YOU**  
**USE THEM**

*Mark or report all  
 defective ones  
 immediately—*

NATIONAL SAFETY COUNCIL

Keep an eye  
 out for  
**NAILS**  
 and  
**SLIVERS**

**IF YOU ARE INJURED BY ONE**  
**— GET FIRST AID —**  
**AT ONCE**

NATIONAL SAFETY COUNCIL

**I'm the**  
**Time Clock**

and I'm worried. I'm worried after  
 every shift when you boys check out.  
 More than twice as many people  
 are killed on the streets and highways  
 as are killed in our industries. Less  
 than half as many people are killed at  
 work as are killed at home. When I  
 think of this, I can't help worrying—  
 wondering if you will get back safely.  
 Continue your safe habits away  
 from the plant.

NATIONAL SAFETY COUNCIL

**WARNING**  
**TO BYSTANDERS**  
 Don't even glance at the arc  
 of an electric welder without  
 welder's goggles. It may  
 cause you hours of intense  
 pain in your eyes

NATIONAL SAFETY COUNCIL

**HE**  
**THOUGHT**  
**IT WAS SAFE**

**'HELL**  
**MAKE SURE**  
**NEXT TIME**

NATIONAL SAFETY COUNCIL

**AN ICY WALK  
DANGER TO ALL  
MAKE IT SAFE  
PREVENT  
A FALL**



NATIONAL SAFETY COUNCIL



We are having fewer accidents this year than ever before and the credit is yours. You are making a good safety record—Keep up the good work

---

NATIONAL SAFETY COUNCIL

I THOUGHT I WAS A LOST SOLE WHEN THAT STEEL PULLEY WAS DROPPED ON ME TODAY!

IT'S LUCKY FOR US OUR OWNER WEARS SAFETY SHOES!



**BE KIND TO YOUR FEET**  
WEAR YOUR SAFETY SHOES  
NATIONAL SAFETY COUNCIL

... IF EVERYONE WOULD BE MORE CAREFUL, THE FOLKS WHO MAKE ARTIFICIAL LIMBS and CRUTCHES WOULD BE MAKING BASEBALL BATS and GOLF STICKS. ....

*Cartoon Bill*



NATIONAL SAFETY COUNCIL

"You'd better take Jenkins-*I KNOW* he's a Safe Worker"





NATIONAL SAFETY COUNCIL

**BEING CAREFUL**  
*is better than*



**(MAYBE)**  
**BEING LUCKY**

**WONDER WHAT A HAMMER THINKS ABOUT**

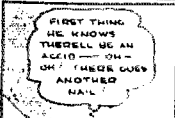
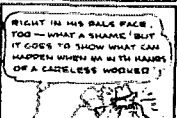
<p>GEE I WISH THIS BELLOW WOULD LEARN HOW TO USE ME — HE HOLDS ME TOO CLOSE TO THE HEAD INSTEAD OF AT THE END OF THE HANDLE —</p> 	<p>AND HE NEVER HITS A NAIL SQUARELY. THE NAIL'S SIDE ALWAYS SLINGS AROUND — AND OOPS HE GETS SORE!</p> 
<p>FIRST THING HE KNOWS THERE'LL BE AN ACCID — OY — OH! THERE GOES ANOTHER NAIL.</p> 	<p>RIGHT IN HIS BALK FACE, TOO — WHAT A SHAME! BUT IT GOES TO SHOW WHAT CAN HAPPEN WHEN YOU'RE IN THE HANDS OF A CARELESS WORKER!</p> 

NATIONAL SAFETY COUNCIL



**HOW ARE YOUR EYES?**

MAYBE IT WOULD PAY YOU TO HAVE THEM EXAMINED

NATIONAL SAFETY COUNCIL

**IT ISN'T HOW WELL YOU DROVE LAST YEAR OR LAST MONTH**

**IT'S HOW SAFELY YOU DRIVE TO-DAY THAT COUNTS**

NATIONAL SAFETY COUNCIL

## Safety

Engineers tell us  
Atlas Slings

# SPEED UP LOADING

Endless construction  
increases safety

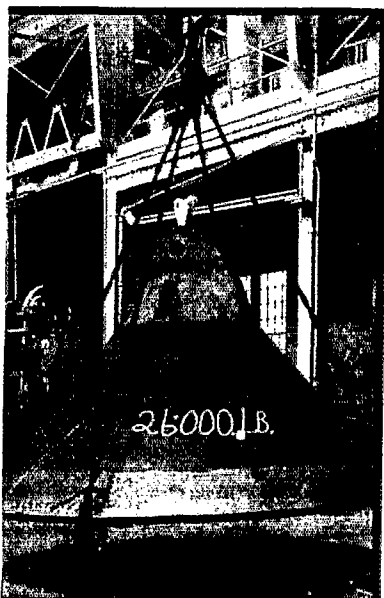

● Here's why Atlas Slings are safer: They are made of two endless elements of Monarch Whyte Strand wire rope—spliced endless—then braided.

This exclusive braided construction gives an unusually high safety factor — reduces danger of accidents both to men and materials.

Foremen who have made time studies report that Atlas Slings speed up loading from 20 to 40%. And give longer service, too. They have great flexibility—straightening out quickly without kinking or spinning.

Atlas Slings are custom-built for all kinds of lifting jobs. Write for catalog. MACWHYTE COMPANY, Kenosha, Wis.

**MACWHYTE  
WIRE ROPE**

*Slings*

ATLAS • DREW • MONARCH

Ad No. 153-A

## Preventing Tuberculosis

(Continued from page 33)

self, and of course, which will not involve any risk to other employees. These cases are examined every few months, the medical supervision being similar to a case of minimal activity.

2. The case of minor activity is cared for as his attending physician sees fit. In some cases, home treatment is desirable, and the patient is permitted to do a moderate amount of light work. In these cases, placement is important to make sure that they will not endanger fellow workers. And employment must be suited to their physical condition. These individuals are examined frequently, and given chest x-rays which are viewed in serial, to determine if the case is progressive. Every effort is made to carefully supervise these cases.

This completes the direct methods of finding tuberculosis and preventing the spread of the disease in industry. There are, however, other methods employed which may be termed, indirect. The most important is the case finding system. A complete medical record of every employee is kept and frequently scrutinized. Employees suffering from loss of weight, nervousness, and indigestion are frequently called in for chest-x-rays. It is surprising how many of these obscure symptoms will show tuberculosis. Hemoptysis is rather rare, and only one case has been found in 16 years. Most of the patients exhibit vague symptoms, frequently referable to other parts of the body.

The routine check-up on all cases is handled by the "tickle" system, which eliminates the possibility of overlooking any individual cases. This is one of the most important steps in the prevention work carried on by the medical department.

Another phase is making the patients "health conscious." This is accomplished by personal contact with the physician, who discovers individual health problems and gives advice.

Much depends on the alertness of the industrial nurse. She comes in contact with a great number of employees and frequently patients will mention health problems to her which they are reluctant to bring before the doctor. This is particularly true of female employees.

An alert nurse frequently picks up marked decrease in a patient's weight, a general appearance of ill-being, or minor symptoms elicited from the patient. It is her duty to encourage the employee to see the physician.

Free pamphlets on health are to be

found in the medical department. Bulletins on health are posted about the plant. Cold campaigns have been carried out with marked success, and cod-liver oil groups have been organized yearly. In addition, a dietitian has been retained to give employees advice.

It might be well to comment briefly on pneumothorax treatment. This treatment seems to offer hope to employees for an early return to work. Ambulatory pneumothorax cases do quite well, and apparently are able to do certain types of work without injury.

The value of such a program, as outlined, cannot be overestimated. The incidence of tuberculosis between the years 1923-27 in the Eastman Kodak Company was 123 patients. By following this procedure, between the years of 1928-32, the number was cut down to 65. When we stop to figure the cost of an average to the individual and to industry, this saving has been considerable!

The legal significance of such a program to industry is becoming more pronounced, particularly in states having a wide coverage by compensation laws. We find that pneumoconiosis are frequently accompanied by tuberculosis. This applies particularly to silicosis. In view of the many suits being brought against industry, it is necessary to develop some means of protection.

The Safety department plays a fairly prominent part in prevention work by its elimination of industrial hazards. This is particularly true in the case of dust hazards such as silicosis, anthracosis, etc. Ventilating problems are solved. In addition the department conducts instruction courses for supervisors who have a good opportunity to observe physical deficiencies in the employee.



Still the Greatest Mother

NATIONAL SAFETY NEWS

## PERSONALS

EDWARD R. GRANNISS, for the past eight years safety engineer with The Travelers Insurance Company, has joined the headquarters staff of the National Safety Council as safety engineer in the Industrial Division. Mr. Granniss succeeds Clarence T. Wilson who has returned to Detroit to engage in industrial relations and accident prevention work in a consulting capacity.

Before joining the Engineering Division of The Travelers in 1927 Mr. Granniss had been engaged in engineering work with the Rock Island Railroad and the Western Electric Company.

WALTER H. BURCHETT, of the Standardising Department, Incandescent Lamp Department, General Electric Company, has been appointed safety engineer in charge of all accident prevention work at Nela Park, Cleveland. Mr. Burchett succeeds Dale C. Hughes of the Administration Department who had been in charge of the work pending a reorganization of the Safety Department.

WILLIAM W. HAMILTON, safety director for the Alpha Portland Cement Company, Easton, Pa., died at the Holmes Hospital, Cincinnati, where he had gone to undergo an operation. He was 38 years old.

Mr. Hamilton entered the employ of the Alpha Portland Cement Company at Ironton, Ohio, shortly after graduation from Ohio State University. In 1929 he was transferred to Easton to take charge of safety and welfare work. He was active in the work of the Lehigh Valley Safety Council and the Cement Section of the National Safety Council. Surviving Mr. Hamilton are his widow and two children.

### Respect for Laws

I submit to you that the time to encourage a respect for your traffic laws is the first time an offender has been summoned into court. Teach him respect for the law at this time by a fairly stiff penalty and you have cut him definitely from the ranks of the repeaters.—*Harry H. Porter, Chief Justice, Municipal Court, Evanston, Ill. (Street and Highway Traffic Section)*

NOVEMBER, 1935



*Trapped By Fire*  
**HE FOUGHT HIS WAY  
FREE WITH LUX**

This oil refinery worker actually faced death armed with a LUX Lightweight Extinguisher . . . And won, hands down.

He was checking equipment in a centrifuge room when the flames roared up. A spark had ignited spilled oil from a defective pump. A sheet of flame blocked the way to the door, to the switch that would stop the motor which was still pumping oil to feed the advancing blaze. It looked like sure death to him. He knew all about running-oil fires.

Lucky for him there was a LUX Lightweight Extinguisher on the wall a few feet away. With it he started his fight to safety behind a barrage of LUX carbon-dioxide gas . . . Two minutes later he had cut the pump switch and thrown open the door. And inside that room there was no trace of fire! The LUX Lightweight had snuffed it out.

Imagine the thrill that chilled the spines of the plant managers when the fire report reached their desks . . . the thrill of satisfaction of knowing that a human life and thousands of dollars in equipment had depended on their having the right fire extinguisher hanging on that wall at the crucial time . . . and at knowing that their choice, LUX, had come through brilliantly.

If your life depended on it what extinguisher would you pick to fight a blazing oil fire? . . . LUX engineers are competent to help you in the solution of any fire protection problem. Life and property may depend on your contacting



*Drawn to illustrate an actual experience told at right.*

## Walter Kidde & Company

111 West Street



Bloomfield, N. J.

FOR ALL ELECTRICAL AND FLAMMABLE LIQUID FIRES

# Sectional Officers, NSC,

## for 1935-36

THE following officers have been elected by sections of the National Safety Council for the year 1935-36. At the time of going to press, a few sections had not completed their election of officers. These will be published when the lists are complete. Because of restricted space, it is not possible to include the names of those serving on the various committees. Complete lists will be found in the sectional news-letters.

Because of the short space of time between the Congress and the publication of this issue it was possible to obtain only a few portraits of general chairmen. Others will be published in the December issue.

### ASSE-Engineering

General Chairman—C. W. Smith, Standard Oil Co. (Ind.), Chicago.

Vice-Chairman—C. B. Boulet, Wisconsin Public Service Corp., Milwaukee, Wis.

Vice-Chairman—D. L. Royer, Ocean Accident & Guarantee Corp., New York City.

Secretary—W. Dean Keefer, National Safety Council, Chicago.

### Automotive and Machine Shop

General Chairman—C. T. Winegar, Chrysler Corp., Detroit.

Vice-Chairman—Marvin Heidt, Budd Wheel Co., Detroit.

Secretary—M. A. Clark, U. S. Rubber Products, Inc., Detroit.

### Cement

General Chairman—D. B. Coleman, Missouri Portland Cement Co., St. Louis, Mo.

Vice-Chairman—Frederick B. Hunt, Nazareth Portland Cement Co., Nazareth, Pa.

Secretary—A. J. R. Curtis, Portland Cement Association, Chicago.

News-Letter Editor—Jack Dempster, Canada Cement Co., Ltd., Port Colborne, Ont.

News-Letter Editor—W. H. Frater, Cadillac Motor Car Co., Detroit.

### Construction

General Chairman—W. A. Snow, Associated General Contractors of America, Inc., Washington, D. C.

Vice-Chairman for Heavy Construction &

Railroad Contractors—R. J. Reigeluth, C. W. Blakeslee & Sons, New Haven, Conn.

Vice-Chairman for Highway Construction—F. I. Rowe, W. L. Johnson Construction Co., Hicksville, Ohio.

Vice-Chairman for U. S. Engineer Department—Major Elliott Vandevanter, Office of the Chief of Engineers, Washington, D. C.

Vice-Chairman for Building Construction—C. W. Wright, Wright & Kremers Inc., Niagara Falls, N. Y.

Secretary—Robert McKinley, General Accident Fire & Life Assurance Corp., Detroit, Mich.

News-Letter Editor—G. O. Griffin, Dravo Corp., Pittsburgh, Pa.

### Employees' Publications

General Chairman—W. D. Price, Warner Gear Co., Muncie, Ind.

Vice-Chairman for the West—Helen Hurd, Shell Petroleum Corp., St. Louis, Mo.

Vice-Chairman for the East—E. M. Miller, The Philadelphia Gas Works Co., Philadelphia, Pa.

Secretary—Laura G. Jackson, Byllesby Management and Engineering Corp., Chicago.

### Food

General Chairman—C. W. Dempsey, Liquid Carbonic Corp., Chicago.

Vice-Chairman in Charge of Program—S. B. Horrell, The Carey Salt Co., Hutchinson, Kans.

Secretary—D. M. Clark, Society of Grain Elevator Superintendents of North America, Chicago.

News-Letter Editor—C. W. Turning, Goddard & Heinselman, Minneapolis, Minn.

### Marine

General Chairman—E. W. Fiske, Jr., Socony-Vacuum Oil Co., Inc., New York City.

Vice-Chairman in Charge of Posters and Slides—Robert F. Hand, Standard Shipping Co., New York City.

Vice-Chairman in Charge of Publicity—Arthur M. Tode, Consulting Marine Engineer, New York City.

Vice-Chairman for the Pacific Coast—A. O. Woll, General Petroleum Corp. of Calif., Terminal Island, Calif.

Secretary—Carl F. Vander Clute, Admiralty Attorney, New York City.

News-Letter Editor—Henry Blackstone, United States P. & I. Agency, Inc., San Francisco.



W. C. Knoelk



R. C. Haven

### Meat Packing, Tanning and Leather Industries

General Chairman—E. J. McCann, Jacob E. Decker & Sons, Mason City, Ia.

Vice-Chairman—Wilson Palmer, United Shoe Machinery Corp., Boston.

Vice-Chairman—C. B. Magruder, The Wm. Schluderberg-T. J. Kurlde Co., Baltimore, Md.

Secretary—Philip G. Rhoads, J. E. Rhoads & Sons, Wilmington, Del.

News-Letter Editor—L. O. Green, Wilson & Co., Chicago.

### Metals

General Chairman—H. W. Darr, Bethlehem Steel Co., Johnstown, Pa.

Vice-Chairman—A. Berquist, The Youngstown Sheet and Tube Co., East Chicago, Ind.

Vice-Chairman—C. M. Allen, The American Rolling Mill Co., Middletown, Ohio.

Vice-Chairman in Charge of Health—Dr. R. C. Engel, Corrigan-McKinney Division, Republic Steel Corp., Cleveland, Ohio.

Secretary and News-Letter Editor—R. A. Chaffin, Continental Steel Corp., Kokomo, Ind.

### Paper and Pulp

General Chairman—E. E. Grant, The Crystal Tissue Co., Middletown, Ohio.

Vice-Chairman in Charge of Membership—F. L. Irvin, St. Croix Paper Co., Woodland, Me.

Secretary and Program Committee Chairman—George J. Adams, International Paper Co., New York City.

### Petroleum

General Chairman—R. B. Roaper, Humble Oil & Refining Co., Houston, Tex.

Vice-Chairman—A. W. Breeland, Lone Star Gas Co., Dallas, Tex.

Secretary—H. N. Blakeslee, American Petroleum Institute, Dallas, Tex.

News-Letter Editor—W. B. Murphy, Atlantic Refining Co., Philadelphia.

(Please turn to page 52)



C. W. Smith



A. L. Armstrong



W. A. Snow



E. W. Fiske, Jr.



H. W. Darr



C. F. Larson

NATIONAL SAFETY NEWS



*Better Safer...*  
**RESPIRATORS**  
*with the Original*  
**DOUBLE FILTER CHAMBER**  
**DUPOR**  
 REG. U.S. PATENT OFF.

**BULB VALVE TYPE NO. 4**  
 This DUPOR respirator has a clear entrance filter aperture of  $7\frac{1}{2}$  sq. in. It uses special felt filter pads  $5/16$ " thick. Extra pads 4c each. The exhalation valve takes care of moisture and enables easier breathing. Made in soft, high grade rubber with face cloth. Foldable and reversible.

Price \$18.00 per doz.  
 Sample postpaid \$1.50  
 CHIPPEWA-A

DUPOR is really two ordinary respirators in one because of its double filter arrangement. It provides greater filter area thus enabling slower passage of air through the filter pads. This not only enables easier breathing but provides better filtering because more dust and spray is caught. Order your DUPOR today. Once you try it you will never be satisfied with any other.

**THOUSANDS OF DUPOR RESPIRATORS NOW IN USE**  
 Used for all kinds of dusts, smoke, light fumes, vapors and paint spray that is free from harmful gases.

BASIC PATENT NO. 2,000,064  
 DETAIL PATENTS PENDING AND ALLOWED

MANUFACTURED ONLY BY  
**H.S. COVER**

**BULB VALVE TYPE NO. 5**  
 This DUPOR has enlarged adjustable filter chambers of screw cap type and the very large aperture of  $11\frac{1}{2}$  sq. in. Extra  $\frac{1}{8}$ " thick pads 3c each. The exhalation valve takes care of moisture and enables easier breathing. Made of soft, high grade rubber with face cloth. Foldable and reversible.

Price \$24.00 per doz.  
 Sample postpaid \$2.00  
 SOUTH BEND, IND., U.S.A.

## HERE'S A SAFETY SHOE that did A REAL JOB

Take a look at the photograph of this Hy-Test Safety Shoe which did its job although worn to the limit, resoled and worn down again — then read this excerpt from a large manufacturer employing several thousand men.

"This employee had a 1400 lb. casting drop 4 ft. onto the toe of this shoe. His toes were only slightly bruised. Had he not been wearing a pair of safety shoes, he would have had his toes broken or amputated."

Despite its age and wear this Hy-Test Safety Shoe with its patented anchor flange prevented the steel box toe from tipping back...

The final paragraph taken from the same letter:

"The employee wearing this pair of shoes, bought another pair of the same kind."

bears out the confidence workers all over the country have in Hy-Test Safety Shoes. They know the value of the anchor flange in Hy-Test Safety Shoes.

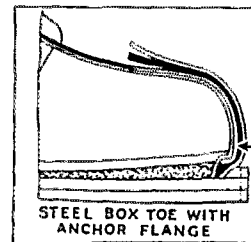

Hy-Test Safety Shoes with the patented anchor flange offer the greatest protection against tipping or pinching back that can be built into a safety shoe.



**HY-TEST SAFETY SHOES**  
 DESIGNED AND MANUFACTURED EXCLUSIVELY BY  
**INTERNATIONAL SHOE COMPANY, ST. LOUIS, MO.**  
 THE WORLD'S LARGEST SHOE MANUFACTURER



## SAFETY PAYS

Accidents are expensive any way you look at them. Not only do they cost real money, but they cause untold suffering, loss of life, and lowered morale of your workers.

Many accidents can be avoided by safeguarding your machinery, and by using H&K Guard Accessories this is not difficult or expensive. Your handy man can make the guards in his spare time.

*All H&K Guard Accessories are under inspection service of Underwriters' Laboratories, Inc.*

**The Harrington & King**  
PERFORATING CO.

114 Liberty St.  
NEW YORK, N. Y.

5645 Fillmore St.  
CHICAGO, ILL.



### Wilson Screwless Shock Proof Portable Lamp Guards

Your maximum safety requirements can be satisfied similarly to other Public Utilities Railroads, Steamship and Industrial Plants, Insurance Companies and State Safety Bureaus who approve and use the Wilson screwless SHOCK PROOF LAMP GUARDS.

**NO DANGER OF SHOCKS—NO SHORT CIRCUITS** to equipment when hung on live bus bars, switchboards or in use around exposed electrical equipment. The Shock Proof flexible oil resistant rubber handle with watertight sealed socket and the completely fibre built flexible guard assure protection, economy and satisfaction. The Patented easy rolling Rubber Ringlock for securing guard quickly to handle eliminates bolts and screws. Requires no tools. Sample on approval. Write now.

**SAFEGUARD ELECTRIC COMPANY**  
30 Church Street New York City

## Sectional Officers

(Continued from page 50)

### Power Press

General Chairman—E. J. Wallman, Great Lakes Forge Co., Chicago.

Vice-Chairman—P. G. Hunter, Motor Wheel Corp., Lansing, Mich.

Vice-Chairman (in Charge of Membership)—B. E. Rockhoff, Detroit Steel Products Co., Detroit.

Secretary—E. H. Meeks, Transue and Williams Steel Forging Corp., Alliance, Ohio.

News Letter Editor—R. M. Zelder, Edison General Electric Appliance Co., Chicago.

### Public Utilities

General Chairman—Roy M. Godwin, Philadelphia Electric Co., Philadelphia.

Vice-Chairman for Telephone and Telegraph Interests—W. P. Elstun, American Telephone and Telegraph Co., New York City.

Vice-Chairman for Gas Interests—John J. Barada, Laclede Gas Light Co., St. Louis.

Vice-Chairman for Electric Interests—W. H. Brown, Northern States Power Co., Minneapolis.

Secretary—H. A. Ptolemy, Public Service Co. of Northern Illinois, Chicago.

News-Letter Editor—R. B. Inman, The Philadelphia Gas Works Co., Philadelphia.

### Quarry

General Chairman—A. Foster, Jr., Warner Co., Philadelphia.

Vice-Chairman—Russell Rarey, Marble Cliff Quarries Co., Columbus, Ohio.

Secretary and News-Letter Editor—Nevin Spe, J. E. Baker Co., York, Pa.

### Rubber

General Chairman—A. M. Dietz, Pennsylvania Rubber Co., Jeanette, Pa.

Vice-Chairman—J. M. Kerrigan, U. S. Rubber Reclaiming Co., Buffalo, N. Y.

Secretary—R. W. Morse, The Firestone Tire & Rubber Co., Akron, Ohio.

News-Letter Editor—J. Polm, The Goodvear Tire & Rubber Co., Akron, Ohio.

### Transit

General Chairman—W. A. Brown, Tennessee Electric Power Co., Nashville, Tenn.

1st Vice-Chairman—H. F. Webb, West Penn System, Pittsburgh, Pa.

2nd Vice-Chairman—A. E. Parker, Winnipeg Electric Co., Winnipeg, Canada.

Secretary—Robert A. McArthur, Public Service Coordinated Transport, Newark, N. J.

### Safety Section AAR—Steam Railroad Section, N.S.C.

Chairman—C. F. Larson, Missouri Pacific Railroad Co., St. Louis, Mo.

1st Vice-Chairman—E. A. Meyer, Chicago, Milwaukee, St. Paul & Pacific Railroad, Chicago.

2nd Vice-Chairman—E. G. Evans, Louisville & Nashville Railroad, Louisville, Ky.

Secretary—J. C. Caviston, 30 Vesey Street, New York City.

### Street and Highway Traffic

General Chairman—William C. Knoelk, Milwaukee Safety Commission.

Vice-Chairman—Lieut. Franklin M. Kreml, Director, Public Safety Institute, Purdue University.

Vice-Chairman—Arnold H. Vey, Traffic Engineer, State of New Jersey.

Vice-Chairman—Burton W. Marsh, American Automobile Association.

Vice-Chairman—Lewis W. McIntyre, Pittsburgh Motor Club.

Vice-Chairman—C. J. Rutland, Dallas, Tex., Traffic Commission.  
 Secretary—Earl J. Reeder, National Safety Council, Chicago.

**Vehicle Fleet**

General Chairman—R. C. Haven, Continental Baking Co., New York City.  
 Vice-Chairman—W. F. Burk, The Canton Repository, Canton, Ohio.  
 Vice-Chairman—H. Peirce Brawner, Atlantic Greyhound Lines, Charleston, W. Va.  
 Vice-Chairman—J. R. Steele, Oklahoma Gas & Electric Co., Oklahoma City.  
 Secretary—Dwight M. McCracken, Liberty Mutual Insurance Co., Boston.

**Wood Products**

General Chairman—J. A. Purdy, Michigan Mutual Liability Co., Detroit.  
 Vice-Chairman—Harry J. Kelley, American Seating Co., Grand Rapids, Mich.  
 Vice-Chairman—William Haggerty, Edward Hines Western Pine Co., Hines, Ore.  
 Secretary—M. C. Goodspeed, General Electric Co., Erie, Pa.  
 News-Letter Editor—Nils Juell, Hayes Body Corp., Grand Rapids, Mich.

**Awarded Medal for Distinguished Service**



**A**LBERT CREEKBAUM (right) crane follower in the Middletown Plant of The American Rolling Mill Company, was presented with an Armo Distinguished Service Medal by Charles R. Hook, president of the company.

Creekbaum was honored by the company for "quick thinking and acting in an emergency to save human lives." He stopped a runaway crane whose operator had fainted, saving the operator from injury as well as three of his fellow workmen who were eating their lunch in its path.

The American Rolling Mill Company has presented six distinguished service medals during the past ten years to men who have, by quick thinking and acting, helped to save the lives of fellow workmen.

NOVEMBER, 1935

**Save 3 WAYS WITH**

**PROPELLAIR** TRADE-MARK REG

Propellair Exhaust Fans pull out dust, fumes, vapors, smoke, heat, dead air—faster and at less cost. Propellair Ventilating Fans assure healthful, comfortable and productive working conditions.

And they save you these 3 ways:  
 (1) MODERATE EQUIPMENT COST  
 (2) VERY LOW DEPRECIATION  
 (3) LOW CURRENT COST  
 Fully Guaranteed. All PROPELLAIR Ratings Are Certified Ratings

For full description of all PROPELLAIR FANS write today for our 40-page CATALOG

**Write PROPELLAIR, INC. Springfield, Ohio**

**NOW READY**  
*New Cesco Catalog*

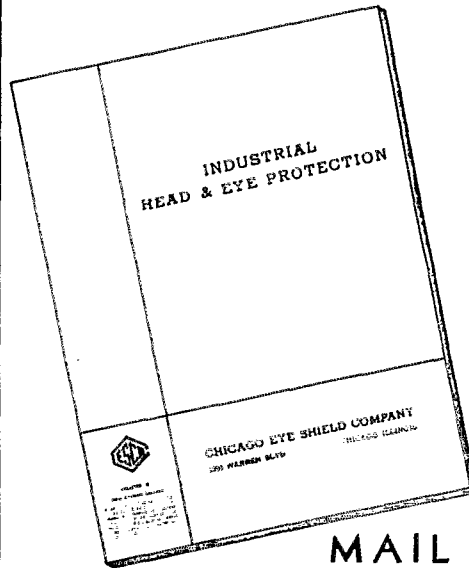

**SEND FOR YOUR FREE COPY**

It's a real hand-book of valuable information on head, eye and lung protective equipment.

**MAIL THIS COUPON**

**CHICAGO EYE SHIELD COMPANY**

2323 Warren Blvd.

Chicago, Ill.

Gentlemen:

Without cost or obligation send me a copy of your new catalog.

Signed .....

Company .....

Street .....

City ..... State .....



## SAFETY

Here's a job that calls for nerves of steel—working on a fifty foot pole—pulling up on a heavy line. In equipment, too, there can be no compromise with quality. Linemen, and those responsible for the safety of linemen, know that the Klein circle on their safety straps and belts, come-alongs, spurs and pliers, sleeve twisters, furnaces and torches, is more than just a trade-mark it spells SAFETY! Only Klein equipment possesses Klein quality.

### Distributed through jobbers

The four pamphlets listed below will be sent without charge to anyone interested. Check the ones you want.

- Safety for the Pole Climber.
- Specifications on Linemen's Belts and Safety Straps.
- The Safety Factor on Linemen's Leather Goods.
- Pocket Tool Guide.



**Mathias KLEIN & Sons**  
Established 1851 **Chicago, ILL. U.S.A.**  
 3200 Belmont Avenue, Chicago, Illinois

## The President's Address

(Continued from page 12)

in the succeeding years. Medicine, psychology and engineering have made their contributions to the advancement of safety. We have taken many a lesson from the advertising profession in presenting our appeals.

Chemistry has contributed much to our material welfare and comfort, but it has also added some new hazards which call for intensive research.

We have learned much about the workings of the human mind and we have a better understanding of the whims of human behavior. We realize, too, the scope of our problem and no longer put our faith in cure-alls. Perhaps we have been too concerned at times with our own favorite remedies to get a complete picture of the problem. But we are beginning to realize that we must consider man's physical, mental and emotional sides in our efforts to preserve his life, health and happiness.

Let us turn now to the administrative side of the Council's experience during the past year. It is most gratifying to report a moderate degree of financial progress. While our income for the past year was about ten per cent greater than 1934, it was only slightly more than half of that for 1929, but careful management has enabled us to maintain the essential services to members.

However, there have been many important new activities which had to be passed by for the time being. Our communities are in urgent need of help with their safety problems and we have done much along this line, but limited resources have prevented us from taking the fullest advantage of opportunities for service. It has become clear to all of us that our public safety activities, on anything approaching an adequate scale, cannot be financed from our usual sources of income. Such a program must depend for its financial support upon public spirited individuals and organizations.

We speak of our accident problem as a national problem, but after all, it is merely a collection of community problems. In industry, safety is largely a departmental affair. The foreman and his men are the shock troops in the fight against accidents. But an army also needs a headquarters and lines of communication. Local organizations must bear the brunt of the work but some central organization is needed to supply information and encouragement. Our National Traffic Safety Contest has

shown what a sound organization and a well-planned program can do toward making any community safer. We hope that other communities will also see the light and redouble their efforts toward this objective.

It has been gratifying to note the attention which safety is now receiving from national magazines. Some time ago the *Atlantic Monthly* blazed the trail with a series of safety articles, and other publications are finding safety an absorbing theme. Recent articles which have appeared in the *American Magazine* (Hoffman), the *Ladies' Home Journal* and the *Red Book* are deserving of your attention.

One of the most startling and widely discussed articles yet published, appeared in the August issue of *The Readers' Digest*. It is entitled, "—And Sudden Death." It presents a sickening picture of the human wreckage resulting from automobile accidents. It has been widely distributed in reprint form by members of the Council and by many other organizations. It is most unpleasant but profitable reading and it is to be hoped that those who read it will stop and think before endangering themselves and others on the highways.

Safety work, however, must not stop with horrible examples. The public's sensibilities must be jolted at times, but a steady diet of horror develops in the individual a protective callousness against shock. Our emphasis must always be on the constructive side.

We like to think of safety as being humane but we know that it is also utilitarian.

When we see the continuing huge totals of accidents still occurring, many may wonder whether accident prevention work is really getting results. Those of us who are close to the work have no doubts, but how do others feel about it?

Let me quote the opinion of one who is a lawyer rather than a safety man, but one who has had opportunities of observing the value of safety work as conducted in industry—I refer to Mr. Henry D. Sayer, former industrial commissioner of the State of New York. In a recent address before the American Bar Association he said: "I believe that safety work has been worth while, and I believe further that if we had not done what we have in this field, accidents would have been so many, compensation might have become so burdensome that the risk would have become uninsurable

and industry would have broken down."

I need scarcely add that accidents in industry have not yet reached the irreducible minimum and that industry must still control all sources of waste if it is to show a profit.

Compensation laws focused our attention on the cost of industrial accidents, yet these comprise a comparatively small proportion of the total. Other accident losses, for the most part, fall with crushing weight upon the individual victim and his family. But the victims are not the only ones who pay. The accident tax, like any other indirect tax, is paid without our realizing it. We do not realize the terrific drain on our national resources, nor do we realize that for thousands of persons each year, accidents make the depression permanent. The case records of our organized charities contain ample evidence of the devastating effects of accidents and disability on family life.

By any standards of comparison, accidents rank high among our many serious social and economic problems. We are faced with a task calling for our best efforts, and it is from you who constitute the membership of the National Safety Council that the inspiration and leadership must come.

## INSURE PROTECTION BY

# DUST CONTROL

- DUST is a costly business partner. It works overtime . . . causing wear and corrosion of machinery and equipment. It soils products and spoils stocks. It is a health hazard.

Why continue to pay these costly tributes to DUST when Pangborn engineers, with over thirty years Dust Collecting experience, can help you CONTROL THIS MENACE? We have solved Dust problems in both large and small plants. We can help you too. Write for information.

**PANGBORN**  
WORLD'S LARGEST MANUFACTURERS OF BLAST CLEANING AND DUST COLLECTING EQUIPMENT  
PANGBORN CORPORATION . . . . . HAGERSTOWN, MARYLAND

## BY SPECIAL REQUEST

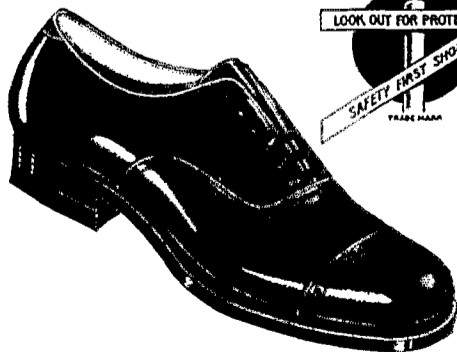

### A Safety Engineer says:

"Your dress and semi-dress Safety Shoes with steel-box toes fill a real need. Our men like the combined safety, comfort and fine appearance—in fact, I wear a pair myself. You should tell the world about them . . . ."

So, by request, we invite YOUR investigation. A sample pair will convince you that SAFETY FIRST DRESS SHOES (as well as our service types) are leaders in the field.

7514  
Black calf Bal oxford (also in Blucher style  
—hi or lo cut)

Write for catalog, prices and samples on approval

## SAFETY FIRST SHOE COMPANY

Pioneer Manufacturers of Safety First Shoes—for Over 35 Years

## Announcing

# A New 4 EYELET ALL RUBBER SAFETY SHOE

Industry Works  
in  
Lehigh Safety Shoes

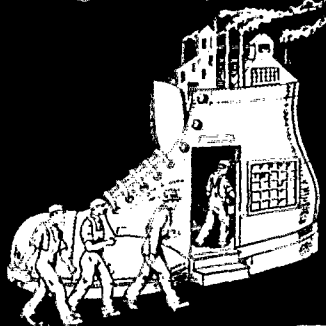

Copyrighted 1925 by Lehigh Safety Shoe Co.

Reduces Sweating and Prevents Burning Feet  
No More Curly, Lumpy, Shifting Insoles



No. 110—Men's Black All Rubber Medium weight. GENUINE LEATHER INSOLE, SAFETY BOX TOE, 4 Eyelet Blucher Tie.

Sizes 5 to 12 (including ½ sizes)

IN STOCK

**LEHIGH SAFETY SHOE CO.**  
31 S. SEVENTH ST. ALLENTOWN, PA.

## FERALUN Anti-Slip Treads

Also Bronzalun,  
Alumalun and Nicalun

PREVENT ACCIDENTS  
ON STAIRS and FLOORS

A hard metal matrix into which is cast an abrasive next in hardness to the diamond assures durability and anti-slip efficiency.

ALL ARE FIREPROOF

Originators and developers of Abrasive metals for  
SAFE WALKWAYS

Specify Feralun and Be Sure

**AMERICAN ABRASIVE METALS CO.**  
Irvington, New Jersey

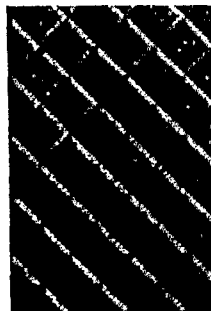

## No-Injury Contests

(Continued from page 30)

International Paper Co., Riley Mill, Riley, Maine. 116,298 hours, no injuries.  
DIVISION II

Container Corporation of America, Natick, Mass. 166,846 hours, no injuries.

Texas Corrugated Box Co., Dallas, Texas. 141,340 hours, no injuries.

Southern Container Company, Houston, Texas. 129,016 hours, no injuries.

United States Gypsum Co., Genoa, Ohio. 82,084 hours, no injuries.

### Petroleum Section

Participating units in the Petroleum Contest this year numbered 217 with 251,458 employees working 266,747,340 man-hours. The average frequency rate was 11,903, a decrease from the frequency rate of 12,710 in the last contest. In this contest 32 plaques were awarded and fourteen certificates, the plaques being presented to the following:

#### MANUFACTURING DEPARTMENT, GROUP A

Empire Oil & Refining Co., Bartlesville, Okla. 824,686 hours, 1 injury.

#### GROUP B

Indian Refining Co., Lawrenceville, Ill. 555,323 hours, no injuries.

The Ohio Oil Co., Findlay, Ohio. 308,100 hours, no injuries.

Wadhams Oil Co., Milwaukee, Wis. 196,234 hours, no injuries.

Shell Oil Co. of Canada, Ltd., Montreal East, Que., Can. 113,285 hours, no injuries.

Lago Petroleum Corp., Maracaibo, Venezuela, S. A. 109,338 hours, no injuries.

Anderson-Prichard Refining Corp., Cyril, Okla. 104,398 hours, no injuries.

The Derby Oil Co., Wichita, Kansas. 94,697 hours, no injuries.

Pasotex Petroleum Co., Texas. 68,296 hours, no injuries.

Stanolind Oil and Gas Co., Tulsa, Okla. 67,347 hours, no injuries.

#### MARKETING-WHOLESALE DEPARTMENT, GROUP A

Continental Oil Co., Ponca City, Okla. 3,633,411 hours, 11 injuries.

#### GROUP B

The Ohio Oil Co., Findlay, O. 376,529 hours, no injuries.

Texas Pacific Coal & Oil Co., Fort Worth, Tex. 143,749 hours, no injuries.

The Derby Oil Co., Wichita, Kansas. 120,679 hours, no injuries.

#### MARKETING-RETAIL DEPARTMENT, GROUP A

Standard Oil Co. (Indiana), Chicago, Ill. 14,293,732 hours, 40 injuries.

#### GROUP B

Texas Pacific Coal and Oil Co., Fort Worth, Tex. 199,310 hours, no injuries.

Cities Service Oil Co., Chicago, Ill. 160,613 hours, no injuries.

Pan American Petroleum & Transport Co., New York, N. Y. 88,046 hours, no injuries.

#### DRILLING DEPARTMENT

The Carter Oil Co., Tulsa, Okla. 67,433 hours, 1 injury.

NATIONAL SAFETY NEWS

PRODUCING DEPARTMENT, GROUP A  
The Continental Oil Co. of Ponca City,  
Okla. 1,391,749 hours, 4 injuries.

GROUP B

Hope Construction & Refining Co., Pitts-  
burgh, Pa. 357,640 hours, 1 injury.

NATURAL GASOLINE DEPARTMENT

Lone Star Gasoline Co., Dallas, Tex. 194,  
912 hours, no injuries.

Shell Oil Co., Los Angeles, Calif. 118,204  
hours, no injuries.

Hope Construction & Refining Co., Pitts-  
burgh, Pa. 108,272 hours, no injuries.

The Ohio Oil Co., Findlay, Ohio. 97,095  
hours, no injuries.

PIPE LINE DEPARTMENT, GROUP A

Standard Pipe Line Co., Inc., Shreveport,  
La. 510,168 hours, no injuries.

GROUP B

Oklahoma Natural Gas Co., Tulsa, Okla.  
207,205 hours, no injuries.

Ajax Pipe Line Co., Tulsa, Okla. 144,513  
hours, no injuries.

Tidal Pipe Co., Tulsa, Okla. 128,546 hours,  
no injuries.

Tide Water Pipe Co., Ltd., Bradford, Pa.  
127,414 hours, no injuries.

Shell Oil Co., Los Angeles, Calif. 124,448  
hours, no injuries.

Standard Oil Co. of New Jersey, New York,  
N. Y. 50,613 hours, no injuries.

Public Utilities Section

One hundred and thirty-one units  
competed in the Public Utilities contest  
this year, 135,168 employees working a  
total of 281,365,620 man-hours. The  
average frequency was 7.510, a slight in-  
crease over the rate of 7.472 for last  
year. In this contest 18 plaques were  
awarded and seven certificates, the  
plaques being presented to the follow-  
ing:

COMBINATION GAS & ELECTRIC DIVISION,  
GROUP A

Central Illinois Light Co., Peoria, Ill. 1,978,  
291 hours, 3 injuries.

GROUP B

Panhandle Power & Light Co., Borger, Tex.  
334,491 hours, no injuries.

Eastern Oregon Light & Power Co., Baker,  
Oregon. 162,866 hours, no injuries.

Moncton Electricity & Gas Co., Ltd., Mon-  
cton, N. B., Canada. 107,968 hours, no in-  
juries.

ELECTRIC DIVISION, GROUP A

Duquesne Light Co., Pittsburgh, Pa. 5,612,  
804 hours, 18 injuries.

GROUP B

Savannah Electric and Power Co., Savannah,  
Ga. 447,900 hours, no injuries.

Fall River Electric Light Co., Fall River,  
Mass. 419,456 hours, no injuries.

Erie County Electric Co., Erie, Pa. 351,134  
hours, no injuries.

Maine Public Service Co., Presque Isle,  
Maine. 172,324 hours, no injuries.

Worcester Suburban Electric Co., Uxbridge,  
Mass. 161,220 hours, no injuries.

Gloucester Electric Co., Gloucester, Mass.  
159,140 hours, no injuries.

Newport Electric Corporation Newport,  
R. I. 148,344 hours, no injuries.

Citizens Power & Light Co., Council Bluffs,  
Iowa. 126,075 hours, no injuries.

NOVEMBER, 1935

Everything  
**BULLARD**  
in Safety

# BULLARD



## HARD BOILED HAT

### AT BOULDER DAM

Six Companies demonstrate that  
head accidents can be prevented.  
Workman struck on head by tim-  
ber. Life saved by Hard Boiled  
Hat.

### OIL REFINERY

Cable hanger's head caught be-  
tween coke conveyor and tractor.  
Lower jaw fractured. No skull in-  
jury due to his Hard Boiled Hat.

### OPEN CUT MINE

Ten-pound rock fell 50 feet.  
Knocked man down and out. Head  
slightly lacerated. Hard Boiled Hat  
saved his life.

### COPPER MINE

Axe dropped down manway. Pene-  
trated crown, cut miner's scalp.  
A no lost time accident, due to a  
Hard Boiled Hat.

Any distributor listed below will tell you  
about the five available models.



NATION-WIDE  
SERVICE

### SOUTH MID-WEST

### WEST

CHATTANOOGA, TENN. C. D. Genter Company, Chattanooga Bank Building  
DETROIT C. H. Dockson Company - 2885 East Grand Boulevard  
CHICAGO E. D. Bullard Company - 215 South Leavitt Street  
GREEN BAY, WIS. Safety Service Company - 108 No. Quincy Street  
DULUTH W. P. & R. S. Mars Company - 374 W. Michigan Street  
HOUSTON E. D. Bullard Company - 1 Main Street

SAN FRANCISCO E. D. Bullard Company - 275 Eighth Street  
LOS ANGELES E. D. Bullard Company - 1229 South Olive Street  
SALT LAKE CITY E. D. Bullard Company - 1620 Yalecrest Avenue

EAST NEW YORK W. S. Wilson Corporation - 123 Varick St.  
PITTSBURGH Safety First Supply Co. - Brady Building  
PHILADELPHIA J. A. Hunt Co. - 2036 Sansome St.  
CLEVELAND Safety Clothing Co. - 3804 Payne Ave.  
BRAintree, MASS. Direct Sales Co. 106 President Road



# Frank

Patented August 25, 1925

Knee Leggings Hip Leggings Spats 3804 Payne Ave. Cleveland, Ohio

## DEPENDABLE LEG PROTECTION

Reduce accidents and compensation  
costs with these protective leggings.

"FRANK" LEGGINGS are built for—

1. SAFETY
2. SERVICE
3. COMFORT

In use in nearly 1000 Foundries, Steel  
plants and Welding shops.

Write for complete folder

THE SAFETY CLOTHING  
COMPANY

Manufacturers

"Everything from a finger cot to an  
asbestos suit"

# MAKE THE JOB EASIER AND SAFER

## WEAR RAW-CORD SOLES AND HEELS

Fully Protected by Patents  
—Any Infringement will  
be Prosecuted



**M**ILLIONS of Men and Women employed in many of the World's leading industries enjoy the Non-Slip Safety Features of Raw-Cord and Gro-Cord Soles and Heels. The use of native cotton grown right here in the U. S. provides the raw material from which Raw-Cord and Gro-Cord Soles and Heels are made. The cotton is woven into tightly twisted cords which are placed upright in the Soles and Heels leaving the ends exposed to the wearing surface. The ends of the Cords provide the Non-Slip feature which has made Raw-Cord and Gro-Cord famous. See that your shoes have these soles and heels and they will convince you that they really do "Make The Job Easier and Safer."

GRO-CORD and RAW-CORD soles and heels are used in dairies, on farms, iron and steel foundries, railroad shops, auto factories, gas and electric plants, ice and fuel stations, stone quarries, mines, general warehouses—where Safety is an important factor, also street and office.

**The Lima Cord Sole & Heel Co., Dept. 7-F, Lima, O.**



### NON-SLIP SOLES AND HEELS

For the First Time Vacuum Cleaning Made Applicable to All Plant Cleaning Requirements at Low Cost with BREUER'S BALL BEARING TORNADO PORTABLE INDUSTRIAL VACUUM CLEANER

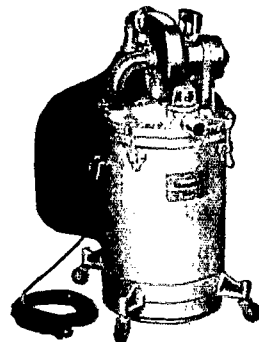

Solves all cleaning problems without expense of installing a stationary plant or using semi-portable cleaners which are too heavy and expensive for average plant applications.

Combines light weight (only 40 pounds) with tremendous cleaning power (1 HP G.E. ball bearing motor—46 1/2" waterlift).

Removes dust, dirt, metal filings, etc. Special attachments for cleaning boiler tubes, ovens, machinery, walls, floors, etc. Sprays paint and insecticides.

Reduce the dust hazard which so vitally affects the safety and health of your employees by using this new machine.

Write for details and further information.

**BREUER ELECTRIC MFG. CO.**

858 Blackhawk Street

Chicago, Ill.

Canada Electric Co., Ltd., Amherst, Nova Scotia, Canada. 116,025 hours, no injuries.  
Kaministiquia Power Co., Ft. William, Ont., Canada. 81,324 hours, no injuries.  
Gas Division, GROUP A

The Laclde Gas Light Co., St. Louis, Mo. 2,274,476 hours, 3 injuries.

#### GROUP B

Reserve Gas Company, Pittsburgh, Pa. 313,464 hours, no injuries.

Peoples Gas Company, Port Arthur, Texas. 146,979 hours, no injuries.

#### Rubber Section

Thirty-six units were registered in the fourth annual contest of the Rubber section. Sixty-seven thousand, seven hundred sixty-eight persons worked 60,090,000 man-hours on an average frequency rate of 6.291, which is a two per cent decrease from the 1934 rate of 6.430. Plaques were awarded to the following:

#### GROUP A

U. S. Rubber Products, Inc., Naugatuck Footwear Div., Naugatuck, Conn. 5,045,246 hours, 9 injuries.

#### GROUP B

The B. F. Goodrich Co., Pacific Div., Los Angeles, Calif. 56,268 hours, no injuries.

#### GROUP C & D

Samson Tire & Rubber Corp., Los Angeles, Calif. 657,456 hours, no injuries.

The Goodyear Tire & Rubber Co., Bowmanville, Canada. 393,711 hours, no injuries.

Van Cleef Brothers, Chicago. 127,068 hours, no injuries.

The Richardson Co., New Brunswick, N. J. 88,653 hours, no injuries.

#### Vehicle Fleet Section

In the Vehicle Fleet Contest plaques were awarded only to the winners of those groups which had a large number of entries. Winners in smaller groups received certificates. Fifteen certificates were awarded to fleets which completed the year with perfect records but whose exposure was too small to qualify for a plaque. The winners follow:

#### INTER-CITY BUS OPERATIONS

Large Fleets—Greyhound Lines, Cleveland, Ohio.

Small Fleets—The Utah Idaho Central Railroad Co., Ogden, Utah. (Perfect record.)

#### CITY BUS AND TAXICAB

Large Fleets—Triple Cities Traction Corp., Binghamton, N. Y.

Small Fleets—Baton Rouge Electric Co., Baton Rouge, La.

#### PASSENGER CAR

Group I—Sinclair Prairie Oil Co., Tulsa, Okla.

Group II—Texas Pacific Coal and Oil Co., Fort Worth.

Group III—Southern Sierras Power Co., Riverside, Calif.

Group IV—Frie County Electric Co., Erie, Pa.

#### INTER-CITY TRUCKING

Large Fleets—Southwestern Transportation Co., Texarkana, Tex.

Small Fleets—U. S. Engineer Department, Gulf of Mexico Div. (Perfect record.)

#### DAIRIES

Louisiana Creamery, Baton Rouge, La.

#### PUBLIC UTILITIES

NATIONAL SAFETY NEWS

Large Fleets—Atlantic City Electric Co., Atlantic City, N. J.  
 Small Fleets—Connecticut Power Co., New London Div.  
 MISC. MANUFACTURING PLANTS  
 Pittsburgh Steel Co., Monessen, Pa.  
 PETROLEUM  
 Large Fleets—Atlantic Refining Co., Baltimore, Md.  
 Small Fleets—Shell Petroleum Co., Houston Refinery.  
 BAKERIES  
 Large Fleets—Junge Baking Co., Joplin, Mo.  
 Small Fleets—Nolde Bros., Norfolk, Va.  
 NEWSPAPERS  
 Canton Repository Co., Canton, Ohio.  
 CITY TRUCKING  
 Large Fleets—U. S. Engineer Dept., South Pacific Div. (Perfect record.)  
 Small Fleets—U. S. Engineer Dept., North Atlantic Div.  
 DEPARTMENT STORES  
 Large Fleets—United Parcel Service Co., West Div. of Los Angeles.  
 Small Fleets—United Parcel Service Co., Ventura and San Bernardino.  
 COAL AND ICE  
 Large Fleets—Central California Ice Co., Turlock, Merced and Modesto.  
 Small Fleets—Raney Wood Coke Co., Swedeland, Pa.  
 LAUNDRIES  
 Large Fleets—Troy Launderers & Cleaners, Minneapolis.  
 Small Fleets—Elk Laundry Co., St. Paul.  
 BEVERAGES  
 Large Fleets—Coca Cola Bottling Co. of New York, Newark, N. J.  
 Small Fleets—Coca Cola Bottling Co. of New York, Bridgeport, Conn. (Perfect record.)

## GREATER SAFETY for Men Working in POISONOUS GASES

THE longer, more reliable service, and the secure feeling which results from the use of the Davis Gas Mask, will aid your men at their work. The care and precision with which each Davis Gas Mask is made—using methods acquired during years of experience in safety service—assure you of uniform, longer gas protection.

A distinctive feature of the Davis Mask, an offset in the face piece, insures a tight seal with a minimum of tension on the head straps. This means greater comfort for your men.

The important features of design and construction which make the Davis Gas Masks of particular value to you are fully described in our Bulletin.

Use the coupon to send for your copy today.

### DAVIS EMERGENCY EQUIPMENT CO., INC.

Chicago, Ill. • New York City • Houston, Tex.  
 Davis Emergency Equipment Co., Ltd. • San Francisco



The Davis (M1) Mask illustrated, is used against all classes of gases except carbon monoxide.

Davis Emergency Equipment Co., Inc.  
 55 Van Dam Street, New York City

Please send my copy of your Bulletin on GAS MASKS to

Name \_\_\_\_\_  
 Address \_\_\_\_\_  
 City \_\_\_\_\_

## The Most Popular Shoes at the Congress

### THE ALL-PURPOSE SAFETY SHOE

Protects the Sole of the Foot as Well as the Toe  
 A patented super-safe men's Black Elk Blucher with puncture-proof watch-spring steel sole insert, steel box toe, riveted steel shank, heavy single Flex-Dri oak outer sole and leather heel.



\$275

G-50 "Safetoe" Women's Black Calf Blucher Oxford, Treated Oak Leather Sole, 1 1/2" inch Rubber Toe Heel, Goodyear Welt, Hogmer Last, AA—4 to 9, A—3 1/2 to 9, B—3 to 9, C and D—2 1/2 to 9.



\$340

H-100 "Safetoe" Men's Black Elk Blucher, Puncture-proof Sole Steel Box Toe, Riveted Steel Shank, Heavy Single Flex-Dri Oak Sole, Leather Heel Welt, Safetoe Last, C—6 to 12, D and E—5 to 12.

**PATENTED SAFETY SHOE FOR WOMEN**  
 Real protection for women industrial workers is provided by a specially reinforced steel box toe, double leather sole, and steel shank construction. Attractive styling and a wide range of sizes. Goodyear Welt construction.

## Brown Shoe Company ST. LOUIS

Also makers of Brownbilt Shoes for men and women and Buster Brown Shoes for children of all ages.

## ECONOMIC VALUE of Properly Equipped Safety Departments



- ◆ Safety departments, properly organized and equipped to reduce fatalities and injuries among workers, have a very definite economic value.
- ◆ Although factual data is very often difficult to obtain, insurance companies recognize the value of accident prevention through reduced compensation charges.
- ◆ For example, one casualty insurance company reports that a large Pennsylvania manufacturing company's accident cost in 1934 was 15 cents per hundred dollars of payroll as against an average for this company of 56 cents per hundred dollars of payroll for the ten preceding years.
- ◆ We know that STEEL-GRIP gloves and safety clothing are contributing toward the economic operation of industry.

LET US SHOW YOU!



## INDUSTRIAL GLOVES CORPORATION

725 GARFIELD BLVD.  
DANVILLE, ILL. \*

Chicago

Philadelphia

Detroit

## Let's Save 12,600 Lives

(Continued from page 14)

fundamentals of traffic safety. In that crusade I take it upon myself, as its governor, to pledge you the eager, unwavering support of the state of New Jersey.

We have fixed as par for the course of the next five years a 35 per cent reduction in accidents and have alluded to the basic methods which can bring this about. If you can score a birdie or an eagle so much the better. The job is no pushover, but it is certainly a practical possibility and *it can be done* if we unite and co-ordinate our numerous efforts. It seems to me that the National Safety Council itself is in an ideal position to define this objective and foster this united drive. The Council's leadership is nationally recognized. It enjoys the most friendly co-operation of governors, motor vehicles administrators, police chiefs and other officials and organizations. I understand that 33 states and nearly 800 cities are officially enrolled in the National Traffic Safety Contest this year. The definite goal of a 35 per cent reduction by 1940 will fit perfectly into the existing program of this contest. In fact, I believe that the announcement of this aim will still further increase the interest which officials and citizens are already taking in this competition.

I believe, too, that we can sharpen our efforts by taking a cue from the movies in their dramatization of another public program which has met with exemplary success. We hear much lately—and justifiably—of the "G-Men" and their success in the war on crime.

I suggest that what we need in the traffic field is a far-flung corps of "E-Men" to shoulder the essential burdens of *engineering, enforcement and education*. For, whatever the layman may think, improved conditions aren't accomplished by waving a wand or murmuring a fervent wish; success sprouts only from the soil of comprehensive study, keen analysis, intelligent remedies: in short, that administered technique of the safety engineer which is so rapidly becoming a new science.

Pursuing the alphabetical strain into that great mass of highway users, pedestrian and motorist alike, I think we could also profit greatly by a general influx of "C-Men"—those who would make *caution and courtesy* on the road more of a habit than a hope!

All of which simmers down to a single broad requirement: in every community

we need a definite concentration of official responsibility which will serve to harness to this problem an alert public and individual interest in our objective.

With co-operation thus stimulated and properly directed, the rewards of such an effort will be simpler of realization—and these rewards are monumental. In dollars and cents alone they are staggering, and since this is a time when dollars count mightily, the impersonal, material side of the picture is inspiring in itself.

Or consider the human angle. Put this program across, and in 1940 you will have 12,600 friends and neighbors alive who now have the finger of sudden death upon them.

You will have 31,500 others sound and healthy who will otherwise be bedridden, crippled or permanently maimed.

In short, you will save 44,000 families the misery, the mental torture, the indescribable anguish which accompanies grave disaster and beggars appraisal in mere money.

All this you will save—plus a million and three-quarters of those "less serious" injuries: a million and three-quarter broken collar bones, fractured ribs, gashed faces, torn ligaments, pulverized knees, mashed noses, and all the rest of the bloody inventory of the head-on collision or the side-swipe.

This, in a nutshell, is our objective.

We want every state in the union to cut its traffic accidents 7 per cent a year for five years.

We want less misery—less agony—fewer crepes in 1940!

## Safety Had the Spotlight

(Continued from page 17)

As was expected, the demonstration of the effect of alcohol on driver reactions attracted widespread attention. Some difficulty was experienced in finding subjects for the tests in spite of the publicity and the assurance that the finest grade of 100 proof Kentucky Bourbon would be provided. The subjects for the test were finally secured and the experiment conducted by Dr. H. A. Heise before the audience confirmed previous statements regarding the effect of alcohol on drivers' ability.

One hundred and twenty bronze plaques and 74 engraved certificates awarded by the National Safety Council to the winners in seven contests were presented during the week at luncheon meetings held by these sections. These contests were conducted by the Marine, Metals, Paper and Pulp, Petroleum.

NATIONAL SAFETY NEWS

Public Utilities, and Vehicle Fleet Sections. Details on the awards of the seven contests will be found elsewhere in this issue. Another article describes the commercial exhibit at "The Safety Derby" which attracted so much interest during the week.

In addition to the commercial exhibit, several of the sections also staged exhibits in their meeting rooms, displaying guards and other safety devices developed by members and posters and other methods of maintaining interest.

Local newspapers cooperated generously in the amount of space given to safety during the week. With the World's Series a matter of history instead of news, the events of the Congress had less competition on the press wires this year.

In addition to the broadcast of the addresses of the Annual Meeting over an NBC hook-up, nine special broadcasts were arranged by Stations WAVE and WHAS. Members of the Council's executive committee and delegates also spoke before-luncheon clubs and at several of the city's schools.

### Louisville Industries Win Inter-Council Contest

NOT inappropriately the Safety Council of Louisville, host city to the 24th Annual Safety Congress, won first place in the Ninth Annual Inter-Council Plant Safety Contest conducted by the National Safety Council. Thirteen local councils entered a total of 525 plants which employed more than 230,000 men.

Conducted on the basis of improvement only, the contest was won by Louisville which showed a combined record for frequency and severity 58 per cent better than its base rate which is its accumulated rate for previous years. Louisville's frequency rate was 8.52 and its severity rate .15. The city entered 60 plants employing 16,500 men.

The Richmond Safety Council won second place with an improvement of 54.2 per cent and Newark was a close third with an improvement of 54.0 per cent. The awards, consisting of a bronze plaque and two certificates, were made at the Managers' Conference which preceded the Congress. The contest terminated on June 30, 1935.

Passenger: "Suppose my chute doesn't open?"

Pilot: "You'll get down a little quicker, that's all."

NOVEMBER, 1935

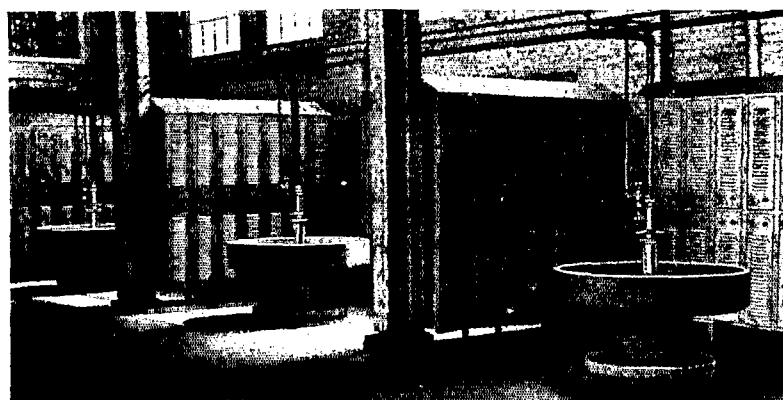

Three of battery of eight Bradley Washfountains in Ingersoll Milling Machine Co. plant

## LEADING MACHINE TOOL BUILDERS USE BRADLEY WASHFOUNTAINS

Such well-known machinery builders as Cincinnati Milling Machine Co., Hendey Machine Co., Ingersoll Milling Machine Co., Kearney & Trecker Co., Mesta Machine Co., Monarch Machine Tool Co., and Allis-Chalmers Mfg. Co. provide their workmen with today's modern group washing equipment.

A group of ten persons may wash at one time and the water used is only a trifle more than what one person uses at an ordinary wash basin.

Installation in new or existing buildings is simplified because there are fewer plumbing connections—a 10-group Wash-fountain requiring but one drain, one hot water and one cold water connection.

### New Catalog Just Out

Our Catalog No. 435 published last month contains complete information on Bradley Washfountains—cast stone, marble, enameled pressed iron and stainless steel models—and Bradley Group Showers. A request will bring you a copy by return mail. BRADLEY WASHFOUNTAIN CO., 2237 West Michigan Street, Milwaukee, Wisconsin.



Industry has welcomed Bradley easy-to-install Group Showers—made in 5- and 3-stall models. Ask for Bulletin 58-S.

## BRADLEY WASHFOUNTAINS AND SHOWERS

### Rubberized Fabric Link Mat

This Non-slip Safety Mat is especially designed for industrial use where there is a slip hazard. In addition, they increase the workers' efficiency as they reduce fatigue brought on by standing on concrete, brick, tile or hard flooring. Ideal for placing in front of machines and where wet conditions exist.

Heavy galvanized wire with cadmium plated clips and plates are used to prevent rust. Furnished in sizes to meet your requirements. Low in cost and long wearing.

Write today for prices and complete information.

**THE BUXBAUM COMPANY**  
Akron, Ohio

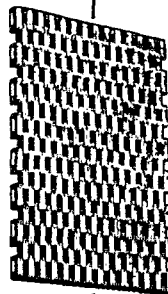

## TO REDUCE ACCIDENT POSSIBILITIES

order the  
**"SAFE-HED" STEEL STAMP**  
**MATTHEWS**  
**"PITTSBURGH HEAVY BEVEL"**

The Safest and Toughest Stamp  
for marking hard Steel

The brilliant performance and endurance of these steel stamps is based on super-excellence in steel—accuracy in bevels—controlled Heat treatment and vigorous inspection.

**NO MUSHROOMING**

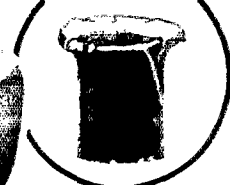

**SAFE-HED**

No Spalling—Cracking or  
Mushrooming. In Short **NO**  
**FLYING PIECES—NO**  
**ACCIDENTS.**

**NO CHIPPING**



Order **SAFE-HED**  
Steel Stamps To-day From  
Address Nearest You

**JAS. H. MATTHEWS & CO.**

● PITTSBURGH—3935 FORBES STREET  
● PHILADELPHIA—403 N. BROAD STREET  
● BOSTON, MASS.—472 ATLANTIC AVE.  
● CHICAGO—3727 BELMONT AVENUE

● NEW YORK—489 CANAL STREET

## FIVE ACES IN THIS DECK!



Hundreds of manufacturers are holding cards like these because they are using **INVINCIBLE INDUSTRIAL VACUUM CLEANERS...**  
**THE FACTS ARE CONVINCING, MAY WE SEND THEM TO YOU?**

**INVINCIBLE VACUUM CLEANER MFG. COMPANY**  
2311 DAVIS ST. DOVER-OHIO

**INVINCIBLE-CLEANED PLANTS ARE ALWAYS SAFE**

## Every Entry a Winner

(Continued from page 29)

chances of dying before their time comes through the careless setting of fire to bed clothing will be greatly lessened by the introduction of the new "Sleepsafe Mattress" exhibited by this company. All of the materials going into this new product are fireproof, also sterilized and vermin proofed. This fireproofing process is equally effective for all flammable fabrics.

The new "Proxate" manufactured from pure beverage gas which was the feature of The Liquid Carbonic Corporation's exhibit is toxic to insect life down to 50° Fahrenheit. This product for infestation control is non-explosive and non-flammable, is harmless to flavor and quality of food products.

Fairway Laboratories, Inc. exhibited for the first time this year a very interesting display of anti-fatigue and heat exhaustion antidote tablets with their handy dispensing equipment.

Safety guards of various types and designs were featured by a number of exhibitors. Junkin Safety Appliance Company kept an interested crowd at their exhibit continuously through their demonstration of the Junkin triple interlock safety guard.

In addition to the usual complete line of guards for all hazards, The Surty Manufacturing Company, Inc., featured an individual exhaust unit for grinding and polishing wheels in connection with a filter system that returns the air to the room freed from harmful dust. The Billymyre pneumatic cleaning unit was also a special feature of this exhibit.

A three-panel display showing samples of various types of wire rope and wire rope safety slings were the center attraction of Macwhyte Company's exhibit. The central panel consisted of a series of push buttons and lights illuminating cross-sections of wire rope with descriptions of the various wire rope shown.

Elliott Service Company made an interesting exhibit of their suggestion systems, safety educational material, foremanship bulletins, posters and other material on problems of efficiency and production.

Again a new departure was made in safety exhibits by Arntzen, Inc., which showed a new method of lifting and moving sick and injured. Any passenger automobile equipped the "Arntzen Way" can be converted into an ambulance in a few seconds without changing the appearance of the car. It is still a passenger car.

Safety treads for all walkway surfaces

**NATIONAL SAFETY NEWS**

was the keynote on which the American Abrasive Company's exhibit was based. Feralun, Bronzalun, Alomalun and Nicalun tread surfaces were featured.

At the Seelbach Hotel an interesting exhibit of all kinds of equipment for the promotion of public safety was made. The following companies had products on display: Automatic Crossing Gates, Inc., Bendix Products Corporation, Eagle Signal Corporation, Evans Products Company, Harley-Davidson Motor Company, John C. Hoof Company, Indian Motorcycle Company, Martindale Electric Company, Peerless Manufacturing Corporation, Safety Signal Devices, Inc., United Motors Service, Inc., United States Steel Corporation Subsidiaries, Victory Methods, Inc., Weaver Manufacturing Company, and Wig-Wag Safety Signal Company.

The daily exhibit prizes were a worthwhile added attraction. The grand prizes, which were drawn on Wednesday night at the Banquet, went to N. P. Sipe, J. E. Baker Company, York, Pa., and Dr. V. C. Baird, Humble Oil and Refining Company, Houston.

The lucky winners on Monday were: Roy S. Bonsib, Standard Oil Company of New Jersey, New York City; R. D. Hazel, Central Ohio Light and Power Company, Findlay, Ohio; Edward Bower, Sargent & Company, New Haven, Conn., and W. W. Williams, Employers Reinsurance Corporation, Kansas City, Mo.

Tuesday's prizes went to W. D. Thompson, Pontiac Motor Company; W. H. McHale, Ocean Accident and Guarantee Corporation, Ltd., Indianapolis; J. William Fehnel, Metropolitan Life Insurance Company, New York City, and H. W. Lawrence, General Motors Corporation, Memphis.

Those winning prizes for Wednesday and Thursday were: J. L. Boardman, Anaconda Copper Mining Company, Butte, Mont.; E. E. Tweed, Mead Paperboard Corporation, Nashville, Tenn.; T. J. Allen, Georgia Power Company, Macon; Fred W. Bagnall, The Detroit Edison Company, Detroit; John S. Hunter, The Atlantic Refining Company, Philadelphia; John W. Mather, Missouri Portland Cement Company, St. Louis, and M. D. Mathews, American Forge and Steel Company, Pontiac, Mich.

"What model is your car?"

"It's not a model, it's a horrible example."

NOVEMBER, 1935

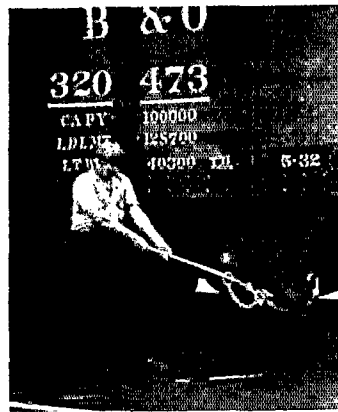

## Close Hopper-Bottom Car Doors with **EASE and SAFETY** with the **Prescott Safety Tool**

This special tool will close hopper-bottom car doors. Prevent smashed fingers, strained backs, ruptures and other serious injuries. Saves time—Is inexpensive.

**The Trumbull Mfg. Co.**  
Warren, Ohio

IF YOU ARE INTERESTED IN

## PUBLIC SAFETY

WE WILL SEND YOU THIS BOOK

★  
EXPLAINS  
"UNEXPLAINED  
ACCIDENTS"

★  
SYMPTOMS  
OF  
CARBON  
MONOXIDE

★  
HOW TO STOP  
NEEDLESS  
DEATHS

★  
A FREE  
GUEST CARD  
FOR YOU!

★

Cities Service, in the interest of public safety, has declared war on Carbon Monoxide. An enlightening booklet of authoritative data on this ever-lurking menace has been especially prepared to assist in putting you on your guard against this danger.

As a member of the 24th Annual Safety Congress and Exposition, you are cordially invited to send for a copy of this valuable booklet and a guest card entitling you to a free Carbon Monoxide safety test on the Cities Service Power Prover.

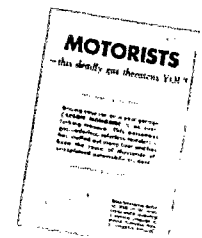

# FREE

Cities Service,  
60 Wall St., Room 710, New York, N. Y.  
Please send me guest card and carbon monoxide booklet.

NAME .....

ADDRESS .....



APPROVED

BY

AMERICAN GAS ASSOCIATION

# B-K INHALATORS

Are widely used at this particular season to resuscitate victims of carbon monoxide poisoning, gas asphyxia and suspended respiration from many causes. . . . Fire Departments, Public Utilities, Iron and Steel Companies and industry in general prefer B-K INHALATORS because of their simplicity of design and ease of operation. Acquaint yourself at once with these outstanding safety devices which are available in two different designs. Don't delay!

Write for Bulletins 104 and 105.

**BISHINGER-KOEHLER**  
 MANUFACTURING COMPANY, INC.  
 7838-42 Kelly Street Pittsburgh, Pa.  
 MANUFACTURERS of OXYGEN EQUIPMENT PRODUCTS



## "EATING" SAND

Way up in the conveyor loft of this large glass-rock plant, many pounds of sand are spilled and spread every day.

When allowed to accumulate, mechanical vibrations and the slightest air currents caused miniature sand storms on all floors below.

Now the powerful vacuum of the Spencer Central Cleaning System is used to keep the loft clean every day. Special tools "eat" the sand at a rapid pace and clean up the finest dust on all floors. All the material is delivered by vacuum to a separator on the ground floor.

Spencer Systems in both the Central and Portable types are reducing health, fire risk and explosion hazards in many industries. Why not send in your plant layout and let our engineers suggest methods for the removal of dirt and dust at its source in your plant?



# SPENCER

CENTRAL AND PORTABLE  
 VACUUM CLEANING SYSTEMS

THE SPENCER TURBINE COMPANY, HARTFORD, CONN.

## Industry's Problem

(Continued from page 32)

put the problem squarely up to them, and they met it squarely. They mentioned the fact that one could always depend upon a driver of the Standard Oil Company to obey all traffic ordinances and to be courteous. In Detroit if you see a Standard Oil truck coming to a corner, you know that you have nothing to fear, he will stop and give you the right of way. Our men said that if one company could have that reputation, there was no reason why we should not have the same.

After several meetings the committee drew up a short Drivers' Club Agreement, which promised to obey all ordinances, to be courteous and to render assistance whenever the occasion arose. They went beyond this and asked the management to advertise in the papers, so that all would know what was being done. The result was that in March, 1930, our company ran a series of ads in all the metropolitan publications, displaying the pledge card, and gave the names of the 450 drivers who had signed. This action of our drivers has spread to many other cities, which shows how the good work once started will increase.

Just one personal incident following this: Our installation superintendent was out in the field when he saw this incident unknown to the driver involved. The man was driving his car along a dirt road which had been made very muddy by recent rains. As he came to a crossing, a lady was having difficulty pushing a baby carriage through the mud. The driver stopped his car, got out and pushed the carriage through the mud and then went on his way. Just a simple thing, but these courtesies all help to build up good will for the company.

In this way, industry, by caring for its own problem has to that extent aided in helping the community problem.

The very life of some of our industries is dependent upon the solution of this traffic problem, because if the traffic toll continues to mount, many people will stop driving with consequent loss not only to the automobile manufacturer, but also to the oil industry and to all dependent upon them, such as rubber, glass, steel, and fabric makers. And yet in some quarters there is opposition to licensing laws on the basis that such laws will tend to lessen automobile purchases. It seems to me that such a view loses sight of the fact that if unfit drivers are allowed to continue to drive automobiles, ultimately the

NATIONAL SAFETY NEWS

situation will react unfavorably on the automobile industry and in consequence on the whole nation. All industry, to a greater or less degree, is affected favorably by public good will, and each of us knows how an efficient, clean, and courteous driver can help build up good will for his employer.

In the second place, industry has in general been the prime backer in all safety campaigns conducted by the community through its police departments. Where the community has offered facilities for testing brakes, lights, horns, steering columns, etc., industry has urged all its drivers to take in their company vehicles for test, and in addition, has urged each employee to have his personally owned car tested. Where the police have conducted special training classes, industry has again urged its drivers to attend and has worked closely with the police to make their efforts worth while. In some special cases, as for instance in Evanston, Illinois, industry has aided in training police officers in first aid so that they might be better equipped to do their work. In some communities, public spirited citizens and industrial organizations have aided the police department in obtaining specially equipped public address cars to assist in carrying on their educational work.

In Detroit when it was made known that many of our school safety patrol leaders lacked rubber coats and boots, and that these helpers were getting wet in bad weather, and then sitting in school in that condition, the industrialists bought the needed equipment.

Why is it that industry represented by its commercial drivers and the younger boys and girls in school are the only groups which continue to consistently lower their accident rates? The reason, I think, is obvious, they are the only two groups which can easily be controlled by nature of their positions. The commercial driver operates his vehicle carefully because he is taught to do so and because his job depends on it. The younger children are in the habit of obeying their teachers and they too are given careful instruction.

As I see it, the only effective way to reduce traffic accidents by the ordinary driver of his or her personally owned car is through fair and firm enforcement by the various community police forces. Education will help, safe engineering of roads and cars will help, radio talks will help, advertisements will help, but when between 85 and 90 per cent of automobile accidents are due to carelessness in some form of the operators, then the

NOVEMBER, 1935

## SAF-T-TOP

### Antiseptic Applicators

Safe to carry in pocket, tool kit, hand bag or first-aid kit — shock proof wooden case prevents breakage of glass container holding solution. Patented feeder tip applies solution like a fountain pen exactly where wanted. Two cc. size treats over 100 average injuries. Pat. closure prevents evaporation & keeps solution at proper



strength.

*The Council on Pharmacy & Chemistry of the American Medical Assn. has accepted the Saf-T-Top dosage form of the following solutions: Iodine, Mercurochrome, Metaphen, Merthiolate, Ferric Chloride and Isopropyl-alcohol.*



*FREE SAMPLE to officials interested in safety. Write today.*

**Robert A. Bernhard**  
Mfg. Chemist

153 ANDERSON AVE. ROCHESTER, N. Y.

## GLOVED HANDS MEAN BETTER WORK

**Y**OUR men will perform more surely and skillfully when no longer made nervous by fear of a painful, perhaps disfiguring accident to their hands. Davis Latex Rubber Gloves will protect their hands—keep them safer from danger.

Then too, these seamless Davis gloves, free from the cumbersome reinforcing strips of ordinary gloves, are more pliant and comfortable to wear. You will appreciate an increase in speed of manual operations with lessened fatigue that this freedom of action gives you.

Tests under actual operating conditions have proved these sturdy Davis Latex Gloves will outwear ordinary gloves to a marked extent.

**Use coupon for information on gloves best suited to your particular types of industrial operation.**

**DAVIS EMERGENCY EQUIPMENT CO., INC.**  
Chicago, Ill. • New York City • Houston, Tex.  
Davis Emergency Equipment Co., Ltd. • San Francisco

Davis Emergency Equipment Co., Inc.  
55 Van Dam Street, New York City  
Please send my copy of your Bulletin on Davis Latex Rubber Gloves to

Name \_\_\_\_\_  
Address \_\_\_\_\_  
City \_\_\_\_\_

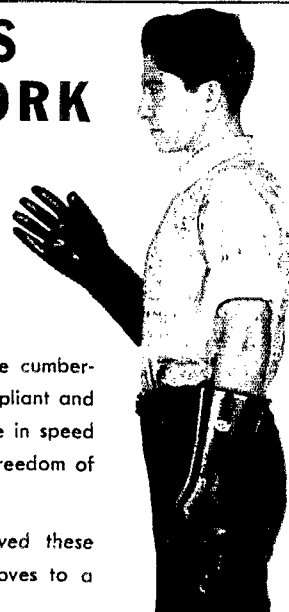

# Install

## JUNKIN NON-REPEAT

Triple-Interlock

# SAFETY GUARDS

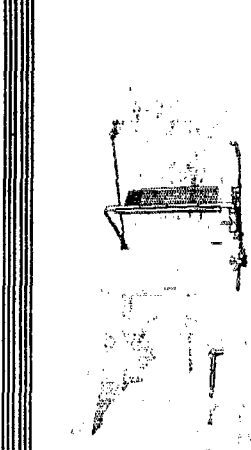

*They pay for themselves  
out of accident compensa-  
tion savings*

When you buy JUNKIN SAFETY GUARDS, you are buying protection, and thereby eliminating the possibility of accidents which take a costly toll in compensation.

Human hands have no spare parts. Why permit your press and shear operators to risk hands that cannot be replaced? Even compensation never pays for such loss.

JUNKIN SAFETY GUARDS—adaptable to all types of stamping presses, shears, etc., retain their safety features over the full range of work handled. Machines cannot be operated until the guard is entirely safe, or repeat an operation unless the guard has dropped to the "SAFETY" position.

These and other features are fully described in literature which will be sent promptly on request. Write for it today.

**JUNKIN SAFETY APPLIANCE CO.**

930-936 West Hill Street

Louisville, Ky.

## PRESENTING New Justrite

# Safety Cans!



**Waste!  
Can**

JUSTRITE'S Automatic oily Waste Cans give you safety, economy, efficiency—opens with foot, closes automatically, leaves both hands free—a great feature! Reduces insurance rate. Capacity: 4, 8, 10, 14 gallons.

Opens with Foot  
Closes automatically

JUSTRITE presents a New Improvement in the 2, 3 and 5 gallon Safety Cans. The carrying handle has been redesigned. This permits "Easier Carrying" and "More Accurate Pouring." Large Spout—easily filled direct from filling station hose—no funnels required.

See how easy it pours—the most efficient can for the workman. Automatic spring controlled spout cap. Natural Hand Grip—opens in one operation—closes automatically. A safe container for carrying explosive and volatile liquids—no leakage or evaporation. Labeled by the Underwriters' Laboratories, Inc., and Approved by the Associated Factories Mutual Fire Insurance Companies.

### LESSENS INSURANCE RATES

Protect your plant—your employees—lower your insurance rate premiums—by installing the latest improved and approved JUSTRITE Safety Device TODAY. See your dealers or write us for interesting prices and literature.

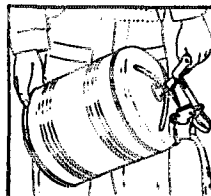

SIZES  
1 pint to  
5 Gallons

# Justrite

TRADE MARK

Justrite Mfg. Co.

2047 Southport Avenue  
CHICAGO, ILLINOIS

only way to make a sizeable reduction in the traffic toll is to control the drivers. And the only sure way to control the majority of drivers is through strict enforcement of the law by the police.

How can industry help in promoting this? They can aid largely in arousing the public to cooperate, because the police can do little if strong public opinion is against them. Here industry with its leaders and its trained advertising men can aid in forming favorable public opinion. If the leaders of industry stand solidly back of the police, there can be little doubt of the success of the efforts expended.

## Maine Safety Conference Shows Amazing Growth

WITH an attendance 75 per cent greater than the record-breaking attendance of last year, the State of Maine held its Eighth Annual Safety Conference at the Eastland Hotel, Portland. It was felt that the State House at Augusta would be entirely inadequate this year, and the optimism of the Department of Labor and Industry proved to be well founded.

This year's conference was expanded to a full two-day program with general and sectional meetings. All-conference luncheons were held on both days.

The program of the second luncheon, which was addressed by W. H. Cameron, managing director of the National Safety Council, was broadcast over Station WCSH. Several mills installed radios for this program.

The conference closed with the presentation of trophies to the winners in the 1935 State Industrial Safety Contest.

The Governor Louis J. Brann Trophy, given to the plant having made the most progress during the year, went to the Saco-Lowell Shops, of Biddeford, makers of textile machinery. Progress in dust control, general intensification of safety effort, and increased managerial interest earned the award for this plant.

Winners of the group trophies awarded by the Department of Labor and Industry were: Cotton—Androscoggin Mills, Lewiston; Metals—Bath Iron Works, Shop Division; Paper—Hollingsworth & Whitney Co., Gardiner; Public Utilities—Cumberland County Power & Light Co., Portland Division; Shoe—Charles Cushman Co., Auburn; Special Paper—St. Croix Paper Co., Woodland; Woodworking—E. I. du Pont de Nemours & Co., Portland; Woolen—Worumbo Manufacturing Co., Lisbon Falls; Miscellaneous—National Biscuit Co., Portland.

NATIONAL SAFETY NEWS



### HERE IS ONE OF MANY MILLS' EXPERIENCES

(Letter on File)

"We have Pyroilized all grease and oil in our plants and find it very beneficial in every way. Not only in the easier running of all shafting, etc., but in cooler bearings, less lubricant and longer life for bearings throughout the plant."

Pyroil has created similar efficiency in many plants. Mail coupon for important facts. Manufactured and guaranteed by Pyroil Company, W. V. Kidder, Pres., 838 LaFollette Ave., LaCrosse, Wis., U. S. A.

The One and Only Genuine Pyroil Bears this Signature on Every Can.

Pres.



A worn, slippery floor is an invitation to oftenserious and sometimes fatal falls. End this hazard once and for all by applying PLASTIC FUT-SURE to floors, stairs, ramps and run-ways. Economical to buy—easy to apply. PLASTIC FUT-SURE is oil and grease proof—easy to keep clean—sure to keep any walking surface permanently safe. Write for folder.

GENERAL ABRASIVE CO., INC.  
2063 Colgate Ave.  
Niagara Falls, N. Y.

## PLASTIC FUT-SURE

FOR SAFER WALKING SURFACES

## The Norris Dam

(Continued from page 22)

square any accident may be described in sufficient detail that corrective or preventive measures are immediately apparent. In order to classify an accident correctly the foreman must analyze the conditions responsible for it, and in so doing becomes increasingly aware of the types of accidents prevalent on his operation and their causes.

It is interesting to note that since the introduction of this form on Norris Dam early in June of this year the frequency rate has shown consistent monthly reductions from a cumulative rate of 64 at the end of May to 56 for June, 52 for July, and 43 for August. Fifteen lost time accidents occurred during the month of July when over 92,500 cubic yards of concrete were placed in the dam (a record daily production) with an exposure of 288,220 man-hours.

Poster boards are maintained and an inter-departmental safety contest conducted at the dam with current standings posted on a huge bulletin board at the main entrance to the works.

No big job is undertaken in the area without a first aid station with a trained attendant in charge. Even on the smallest jobs there is a complete first aid kit and some experienced person on hand to use it if need be. In addition several first aid trucks operate in the area.

Now for the accomplishments of this program:

Since the start of operations at Norris Dam in September, 1933, 311 lost time accidents have been reported. This total includes 6 fatal injuries and one permanent total disability.

During the two year period ending September 1, 1935 a total of 5,055,662 man-hours were worked showing a cumulative frequency rate of 61 lost time accidents per million man-hours worked and a severity rate of 10.26 days lost per 1,000 man-hours exposure. The cumulative non-fatal severity rate for the operation as of September 1, 1935 is 1.95.

The steady downward trend of accidents on Norris Dam in the face of increased physical hazards again illustrates the effectiveness of an organized safety program in which accident prevention becomes an integral part of the everyday duties of each workman, foreman, and supervisor on the job. There is evidence on every side of a mutual feeling of responsibility and concern on the part of the supervisors and workmen for the correction of those conditions and prac-

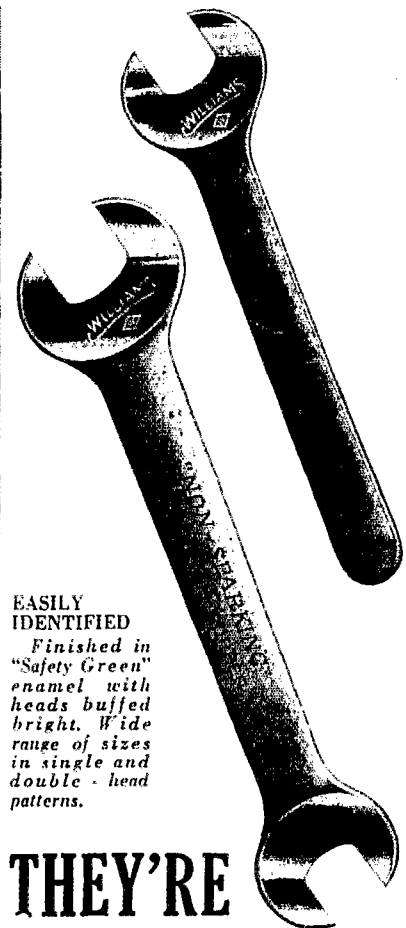

EASILY  
IDENTIFIED

Finished in "Safety Green" enamel with heads buffed bright. Wide range of sizes in single and double-head patterns.

## THEY'RE SAFE

Williams' "NON-SPARKING" Safety Wrenches are designed for use in the presence of inflammable gases, or wherever a spark may produce disastrous results. Drop-forged from beryllium-copper and accurately heat treated, these Safety Wrenches are unequalled in strength, toughness and hardness. They are non-rusting and non-corroding—practically as strong as steel wrenches of similar size and design. Backed by more than 50 years of wrench making experience and guaranteed by the manufacturers of the most complete line of drop-forged wrenches in the U. S. A.

Buy from your mill or safety supply house. Literature on request.

J. H. WILLIAMS & CO.

"The Drop-Forging People"  
75 Spring St., New York, N. Y.  
Western Warehouse and Sales Office, Chicago  
Works, Buffalo, N. Y.

## WILLIAMS

SUPREME DROP-FORGED STEEL

## DROP-FORGED WRENCHES

FOR HOISTING  
FOR LOWERING  
FOR SAFETY

IPCO  
LINEMAN'S INSULATED  
TOOL BAG  
STYLE L



12" diameter by 15" deep. Collapsible—No metal parts. Manufactured of heavyweight hard woven canvas and specially designed, flexible, waterproof leather bottom. Non-metallic ring at top. Rope loop for hanging over pin. Handle holes and loop holes leather reinforced inside and outside.

Equip your line crews with this serviceable bag.

Bulletin giving full description mailed on request.

Get on our mailing list so that bulletins on new Utility products may be sent to you as issued.

**INDUSTRIAL  
PRODUCTS  
COMPANY**

Accident Prevention Equipment  
800 W. Somerset St.  
PHILADELPHIA, PA.

tices which cause accidents. There is a minimum of ballyhoo about safety on Norris Dam—it is just another essential part of everyone's normal duties and Mr. Fulmer helps them do that part better.

**Safety Instruction Cards**

(Continued from page 34)

Poles, dismantling defective	45, 169
Testing before climbing	232
Portable extension lamps	67
Posture	90
Power press operators, advice to	65
Power trucks, operation of	43
Push tools for jointers and saws	38
Rescue work, broken ice	258
Resuscitation, see artificial respiration	
Roll scraper (for cleaning power-driven rolls)	34
Rope knots and hitches	200, 222, 246
Rope hitches and slings	1, 210
Rope, protecting from chemicals	62
Rope and block sizes	88
Ropes, safe loads for	47
Rubber gloves, care of	214
To test for leaks	4
Saws, circular—don'ts	54
Operating speeds	254
Saws, cross-cut—how to carry	194
Hand, how to use	255
Swing cut-off	143
Scaffold planks, identifying	32
Safe loads for	120
How to test	15
Scaffolds, suspended	75
Screw driver	257
Sheaths for sharp pointed tools	184
Shoes, safety	234
Shoring trenches	167
Skidding cylindrical objects	11
Slings, angles and capacity	24
Sling chain hooks	159
Snakebites	201
Soldering	164
Spray coating, general precautions	227
Prevention of fires	277
Stacking cylindrical objects	7
Scissors and shears	240
Spiders, "black widow"	250
Stacking pipe and round bars	114
Stairways, ramps and fixed ladders	37
Stairways, how to use	146
Step ladders	262
Storerooms and stockrooms	130
Suggestions, safety, making	109
Sunburn	199
Sunstroke	66
Tackle, lifting capacity of (wooden shell blocks with manila rope)	61, 69, 86
Lifting capacity of (steel shell blocks with wire rope)	36, 95
Tank cars, loading flammable liquids	50
Opening dome covers	12
Unloading acids	94
Unloading flammable liquids	105
"That tired feeling"	168
Thawing (frozen pipes)	131
Timbers, setting in mines	27
Toolkeepers	136
Tools, portable electric	91
Tree felling	218
Tree trimming	205
Warning signs, colors to use	112
Location	160
Style of lettering	119
Watchmen, suggestions for	35
Water, life saving	223
Weights of materials, dry materials	138
Liquids	213
Wheelbarrow, how to handle	187
Wind force	270
Window cleaning, safety belts	92
From ladders	110
Window glass, carrying	155
Wire rope, how to lubricate	98
Putting on a seizing	268
Safe loads	263
Uncoiling and unreeling	49
When to discard	19
Working beneath a car	25
Worry	148
Wrenches, use of	111

**Safety!** Have You  
Overlooked  
**THIS DOUBLE  
SAVING?**



With the Dayton Safety Ladder you save twice. First, the costs arising from bad accidents! Second, the time of your workmen. This double saving costs very little in a Dayton. Made of durable airplane spruce, it stands firmly. Straight back for close work. Sizes 3 to 16 feet. Write today for full details.

Dept. NSN-11

The DAYTON SAFETY LADDER Co.  
121-123 W. Third St.  
CINCINNATI, O.

**DAYTON  
Safety Ladder**

(Patented)

Stock carried on Pacific Coast by E. D. Bullard Co., Los Angeles and San Francisco, and by 160 other distributors from coast to coast. Made and distributed in Canada by Safety Supply Co., Toronto.

use **DRACCO**  
**DUST CONTROL**  
for *BETTER health*

The manufacturer is forced to assume more responsibility each year for conditions in his plant that impair the health of his employees. Because of high speed production, DUST has become a serious nuisance.

**DUST  
COSTS MONEY**

Wherever DUST is found you not only have a menace to health, but a factor that takes its toll in many ways. Dust is the cause of serious losses in the entire plant. DRACCO Dust Control will eliminate your expensive dust and thereby improve health conditions and greatly increase plant efficiency.



The New DRACCO  
Multi-Bag Filter

Write for Bulletin No. 301

**DRACCO CORPORATION**  
Successors to The Dust Recovering & Conveying Co.  
4073 E. 116th St. Cleveland, Ohio

NATIONAL SAFETY NEWS

# Heard at the Congress

Excerpts of addresses at sessions of  
the Twenty-fourth Safety Congress

## A Living Challenge

And now a word as to your (the National Safety Council's) work in general. It is a splendid work making practical application in a number of fields of the injunction: "Do unto others as you would have them do unto you." Much of this work has been accomplished through a voluntary enlightened humanitarian interest. Much of the work lying ahead must be done through educating your fellow men.

Your work and aims stand as a living challenge to all who would have us believe that humanitarianism is a recent discovery or invention. Your organization stands out as a shining example of being "your brother's keeper." It is a living, strong body whose efforts of study and action should be behind every move to reduce accidents throughout the land. Not through hasty, unenforcible legislation, but through sound progress and education, making every workman and automobile driver conscious of his responsibility to his fellow man. Our organization is happy to endorse your efforts and will be glad to cooperate with you to the fullest extent.—*William S. Knudsen, Executive Vice-President, General Motors Corp. (Annual Meeting of Members)*

## Heat Exhaustion

In 1934 the Youngstown Sheet and Tube Company cooperated with other companies in bringing a group of specialists from Harvard University to Youngstown to study our heat cases. This work showed absolutely that heat cramps were the result of the loss of salt from the body. This work also showed that adding a level teaspoon of salt to a gallon of drinking water was enough to keep the body salt up to the necessary amount. Salt also makes it possible for the body to hold the required amount of water. When our sheet mill men drank plain water they weighed out at the end of the turn on an average of 5.6 pounds lighter than when starting to work. When they drank water having one level teaspoon of salt to the gallon

they weighed out at the end of the turn with an average loss of weight of a little more than one pound. This proved definitely that the salt lost in sweating made it impossible for the body to hold its normal amount of water.—*P. H. Kennedy, M. D. Youngstown Sheet and Tube Co., Youngstown, Ohio. (Heat Exhaustion Session)*

## Safe Toys

"Safe toys." Those two words, if fully realized, would have spelled life for thousands of children now dead and would save hundreds of other children who will die in the next year and every year so long as we not only make it possible for children to play with instruments of death, but actually put death-dealing toys in to their hands.

These are strong words, but I am prepared to prove their truth. *Lewis H. Carris, Managing Director, National Society for the Prevention of Blindness (Child Education Section)*

## Dust Control

It is necessary to stress the fact that quite often the benefits of even the most extensive program of dust control are not immediately realized. This is especially true in dealing with fibrosis-producing dusts in plants where some of the workmen have already inhaled sufficient quantities of dust to cause disability. Moreover, in dealing with such dusts as lead, cadmium, and mercury compounds, control measures may produce salubrious results in a relatively brief period of time.—*J. J. Bloomfield, Sanitary Engineer, United States Public Health Service. (Occupational Diseases Session)*

## Warnings to Motorists

When construction and maintenance work of a utility is to be done on streets and highways it cannot be assumed that the approaching motorist has a weather eye out for barricades, machinery and material. He is not anticipating perils. He probably uses the street regularly

# FOR FIRST AID

When  
**SPEED**  
May  
Save a  
Life!

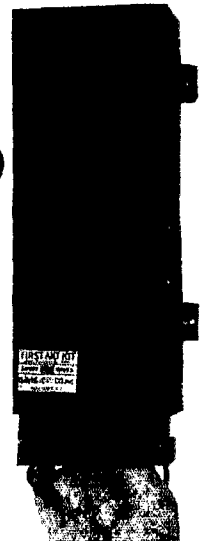

**A**N accident occurs. To be fully effective, first aid must be applied at once. Containing all necessary first-aid supplies, the new DAVIS Brac-Kit can be carried to the scene of an accident in the shortest possible time. Only an outer case is fixed to the wall. The inner case—the compact, fully equipped DAVIS first-aid kit—you

can remove quickly and easily—with one hand. Just lifting the lid, you will find entire contents instantly visible and accessible.

You will appreciate the economy of cost, too.

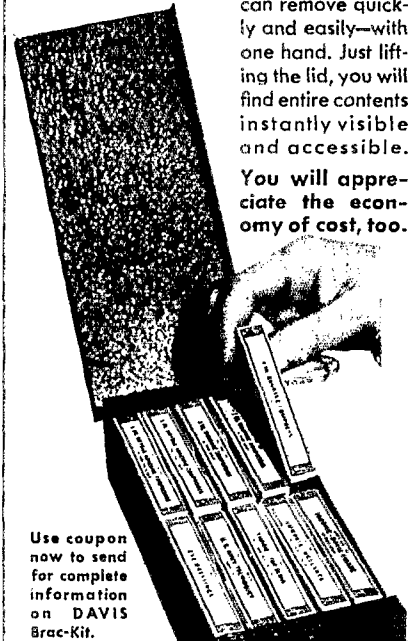

Use coupon now to send for complete information on DAVIS Brac-Kit.

**DAVIS EMERGENCY EQUIPMENT CO., INC.**

Davis Emergency Equipment Co., Inc.  
55 Van Dam Street, New York City

Please send my copy of your Bulletin on  
BRAC-KIT No. 128 to

Name \_\_\_\_\_

Address \_\_\_\_\_

City \_\_\_\_\_

## "Safety First" SUPPLIES

Now is the time to check this list of standard safety supplies and get our prices on those suited to your needs. Every one is of standard, recognized quality.

### GAS MASKS

- ★ Leak-proof eye-pieces, strong carrying case; a canister for every industrial gas.

### RESPIRATORS

- ★ Two types: "Felt Filter," for protection against fine dust and paint spray; and "Sponge Filter" type, for dust, light fumes and smoke. Goggles can be worn with both types.

### GOGGLES

- ★ "Queen" goggles are made in designs to meet practically every requirement.

### OILY WASTE CANS

- ★ Made of heavy galvanized iron, with simple, self-closing tight hinged cover. Moderately priced.

### LADDER SHOES

- ★ Easily pay for themselves by releasing "the man who holds the ladder" for other work. Non-slip inserts are replaceable.

### WATCHMAN'S CLOCKS

- ★ They change UNCERTAINTY to ASSURED PROTECTION. Moderate in price.

### GASOLINE CANS

- ★ Lower your insurance—and save 30% of the liquid usually lost by evaporation. CAN'T EXPLODE. All sizes.

### SAFETY LADDERS

- ★ The famous Dayton Safety Ladder, of clear airplane spruce, sizes 3 to 16 feet. Allows workman to use both hands.

### FIRE EXTINGUISHERS

- ★ "Queen" fire extinguishers have strong, quick, easy action. Leaders for 25 years.

Write for Prices

HARKER MFG. CO.  
121-123 W. Third St.  
Dept. NSN-11  
Cincinnati, Ohio

**Queen**  
FIRE  
EXTINGUISHERS  
FOR EVERY FIRE HAZARD

and drives fast along known routes. This driver cannot stop quickly enough after seeing a small warning sign advising him that construction work is being carried on just a few feet ahead. A crash occurs. The driver may be charged with recklessness because he did not have his car under control, but in many such cases an investigation has convinced the company adjuster that adequate barricades were not erected and sufficient signs were not placed far enough down the street to warn the motorist.—C. J. Rutland, Safety Engineer, Texas Power and Light Co., Dallas, Texas. (Public Utilities Section)

### Thanks to Medical Science

It has not been many years since the average engineer has discovered that a microm is a unit of measure and not "microbe" misspelled. Due, however, to the insistence of our medical friends, we have been forced to familiarize ourselves with this term and even to adopt such medical tools as the Sedgwick-Rafter blood counting cell in our chase after micromic-sized dust particles. This is as good an opportunity as any to thank medical science for showing us the significance of the extremely fine dust particles, at least, from a hygienic point of view and further to thank them for teaching us how to use their tools, at least, to measure and find these particles.—M. I. Dorjan, Blaw-Knox Company, Pittsburgh, Pa. (Automotive & Machine Shop Section)

### Highway Safeguards

What the "limited way" purports to accomplish is to so surround the highway itself with physical guards that failures of vehicles or failures of the human factor will not be translated into disaster, or at least that the seriousness of the disaster will be mitigated. Its function is comparable to machine protection in industrial plants. Dr. Miller McClintock, Director, Bureau for Street Traffic Research, Harvard University. (Street and Highway Traffic Section)

### Fear of Flying

Some folks just can't decide to get off the ground. They remind us of those who still aren't convinced that the horse is gone. Many have never seen a modern airplane. I say modern because there is a vast difference between the airplane of today and a few years ago and we are doing our best to get these people out to our airports to look things over.

Safety is the very keynote of our operations. Everything we do is first determined to be safe, partly because we want to protect our equipment and our own skins, but most of all because the one thing that keeps more people out of the air than any other is fear—fear of the unknown, perhaps, but fear just the same, and the best way to overcome fear is to demonstrate the security of air travel. C. A. Rheinstrom, General Traffic Manager, The American Air Lines, Inc., New York City. (Aeronautical Section)

### Two Fleets Win Honors for Bakery

FIFTY-SIX of the 62 salesmen employed by Nolde Bros., Inc., at Richmond, Va., have qualified for the "No-Accident Driver" medals awarded by the National Safety Council. Of these drivers, 19 had operated four years without accident; 15 had clear records for three years; 10 for two years, and 12 for one year. A group photograph of the drivers who had been honored for safe operation appeared in the Richmond News Leader. By design or by coincidence, the story and photograph appeared on the same page and adjoining an advertisement of the company's products.

In the Vehicle Fleet Contest sponsored by the National Safety Council for the year ending June 30, 1935, the Nolde Bros. fleet serving Norfolk, Va., operated 244,888 miles without accident, winning the trophy among the smaller fleets entered in the Bakery Division.

## COMING EVENTS

Of Interest to Safety Men

Nov. 12-15, Cleveland, O.

International Acetylene Assn. 36th Annual Convention. (Hotel Cleveland). Secretary, H. F. Reinhard, 30 East 42nd Street, New York City.

Dec. 5-6, Washington, D. C.

Highway Research Board of the National Research Council, Fifteenth Annual Meeting. Roy W. Crum, director, 2101 Constitution Ave., Washington, D. C.

Dec. 5-7, New York City

National Society for the Prevention of Blindness. Annual Conference. (Rockefeller Center.) Lewis H. Carris, managing director, 50 West 50th Street, New York City.

Dec. 12, Miami, Fla.

American Association of State Highway Officials. Annual Convention. Executive secretary, W. C. Markham, 1222 National Press Bldg., Washington, D. C.

NATIONAL SAFETY NEWS

## HONOR ROLL

Details of no-accident records in excess of 400,000 man-hours, or 200 working days, are invited for this department

### Carolina Power & Light Co.

Cape Fear Steam Electric Station of the Carolina Power and Light Company operated from October 3, 1927, to October 3, 1935, without a disabling injury. The exposure during this period of 2,227 days totaled 409,394 man-hours.

The Tillery Hydroelectric Station operated from July 1, 1928, to July 25, 1935, without a disabling injury in 471,454 man-hours worked.

### Gulf States Steel Co.

Their first million man-hours without a disabling injury was completed by employees of the nail mill of the Gulf Steel Company, Alabama City Works, on August 2. With an average force of 85 men, the mill has operated without accident since October 6, 1930. The exposure on August 2 reached 1,000,368 man-hours and the record was still intact at the time of reporting.

### Ontonagon Fibre Corp.

On August 31 the Ontonagon Fibre Corporation at Ontonagon, Mich., had completed 227 days without a disabling injury. During this time the 206 employees worked a total of 276,954 man-hours. No accident had broken the record at the time of reporting.

### Mine Safety Appliances Co.

When a disabling injury on May 11, 1934, terminated a safety record of 4 years and 157 days, the Mine Safety Appliances Company, at Pittsburgh, Pa., was not discouraged. The employees at once started to establish a new record and on August 31 had accumulated 1,001,390 safe man-hours.

### Mountain Copper Co., Ltd.

Mococo plant of the Mountain Copper Company at Martinez, Calif., has operated 202 days, (659,047 man-hours) without a disabling injury. The average number of employees has been 58 and all of them are ambitious to make it a whole year.

### Berger Manufacturing Co.

On September 1 the Berger Manufacturing Company, of Canton, Ohio, had worked 336 days with an exposure of more than 1,000,000 man-hours without a disabling injury. This firm is engaged in metal stamping and forming, also in the painting and finishing of lockers, cabinets, etc.

### Shell Petroleum Corp.

No disabling injury in 2,144 days is the accomplishment of the Lube Compounding and Shipping Department of the Wood River, Ill., Refinery of the Shell Petroleum Corp. The no-accident period began September 22, 1929, and on August 5, 1935, the exposure exceeded 1,000,000 man-hours. The record, participated in by an average working force of from 90 to 100 men, was unbroken on October 10.

### Temple Lumber Co.

The Hemphill, Texas, plant of the Temple

Lumber Company operated from November 27, 1934, to June 30, 1935, without a compensable injury. The plant employs an average of 215 men who worked a total of 404,783 man-hours during this period. While this record is based upon freedom from compensable (7-day) injuries, rather than the standard definition of a disabling injury required for the Honor Roll, it is outstanding among companies operating saw mills and consequently is deserving of recognition. During this period the few injuries that occurred were not serious, and in each case the injured men could have returned to light work in the plant.

While the plant was trying for a record which would make the Honor Roll, the most enthusiastic group was the negro safety council, according to Superintendent E. G. Prud'homme.

### Westinghouse Lamp Co.

Twenty months without a disabling injury was completed on September 30 by the Miniature Lamp Department of the Westinghouse Lamp Company at Bloomfield, N. J., with the record still unbroken at the time of reporting. The exposure for this period was 1,733,756 man-hours. Recently this department was awarded a Certificate of Merit by the Newark Safety Council.

Although lamp manufacturing is classed as light manufacturing and regarded by outsiders as comparatively non-hazardous, this is the first time in several years that a lamp department has won the Certificate of Merit. During the same period, several departments of the company engaged in heavier work have received awards for outstanding no-injury records.

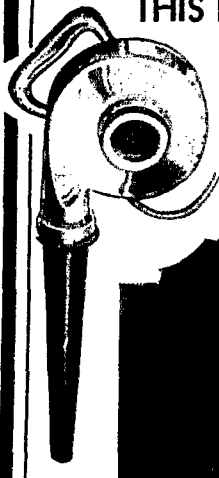

**THIS Portable Tool**  
keeps all other tools and machinery clean and in working order.

- **BLOWS, SUCTION—CLEANS or SPRAYS**

ASK FOR FREE TRIAL

## CLEMENTS - CADILLAC PORTABLE BLOWER ELECTRIC

The most versatile portable shop tool—3 tools in one—can be used to blow, spray, or suction-clean. DRIVES dry air, free from oil, at great velocity but low pressure. Safely, quickly, CLEANS motors, delicate or intricate machinery and equipment. CUTS RISK of "Shorts," burn-outs, fire, excess wear. Convertible to suction cleaner, or sprayer. Plugs in any socket—reaches anywhere.

**CLEMENTS MFG. CO.**

6658 S. Narragansett Chicago, Ill.

## USE a UNION or COLUMBIA CARBOY INCLINATOR



for the SAFE and EASY way to pour acids and chemicals from carboys or small and medium size drums.

A tried-and-proved device attractively priced. Sold on money-back guarantee.

Send for a completely illustrated and descriptive bulletin giving full particulars and prices.

**THE INCLINATOR COMPANY—P. O. BOX 363—MINNEAPOLIS, MINN.**

## SANKEY FOOT GUARDS

Foot protection is easily provided if you have a supply of Sankey Foot Guards available. They are made of 16-gauge steel or Rigidlum, an aluminum alloy. They are light in weight, comfortable to wear and permit free and easy movement. Built to withstand an impact of 300 foot pounds.

Write for your sample

**Ellwood Safety Appliance Company**  
Ellwood City, Pennsylvania



# WITH THE MANUFACTURER

Manufacturers are invited to send in announcements of new products, or improved special features. Only items which can be considered as "news" to our readers will be published

## Special Reflectors for Use with the High Intensity Mercury Vapor Lamp

The Miller Company, Meriden, Conn., has completed extensive research and experiments in the development of correct reflector equipment for mercury vapor lighting and announces specially-designed reflectors which provide for the satisfactory operation of the new mercury vapor lamp. The new equipment includes styles and types of reflectors for any type of mounting, for practically all industrial locations, and for color correction of mercury vapor illumination by individual or combination equipment.

Particularly interesting are the combination reflectors, which permit the use of ordinary incandescent lamps along with the mercury vapor lamp in a single fixture. Lighting systems where the fixtures are alternately mercury vapor and incandescent, do not provide uniform illumination in color unless the units are mounted well above the ordinary line of vision, allowing the incandescent and mercury vapor light to mix thoroughly before reaching working level. When they are not, the visual acuity of operators to distinguish detail varies under the individual lighting units. The production, therefore, varies in appearance. The new combination reflectors can be mounted as low as 8 feet, and everywhere the light will have good color quality, resulting in uniform production.

## Safety Device for Punch Presses

A new safety device for practically all sizes and makes of hand-operated punch presses is announced by David J. Ross Company, Benton Harbor, Mich. It is



known as the "Rousselle." The simplicity and safety of the new device are two of its

main features. It consists of a bar, a one-piece housing, operating lever and long-life spring. Just a touch on the safety lever with the left hand when the press is tripped by the right, releases the punch press lever. In this way, both hands are in use and out of the way of danger every time the press is tripped. And the safety device springs back into place instantly when released, locking the punch lever securely. No extra time or waste motion are involved. The new device, according to the makers, cannot be put out of action, tied down or easily taken off. The one-piece housing prevents tampering.

It is further claimed that any good mechanic can install this safety device in 15 to 30 minutes. Two holes are drilled in the press for the safety bar, and two for set screws for attaching, included with the device. The bar is sawed to proper length to fit the particular press to be guarded. It is then installed, the housing is put in place, and the screws tightened. Once on, no adjusting or further attention are required.

## New Water Cooler

Water of the proper temperature as well as being dispensed in a sanitary manner contributes in many ways to personal safety. The Ebco Manufacturing Company, formerly the D. A. Ebinger Sanitary Company, Columbus, Ohio, announces a

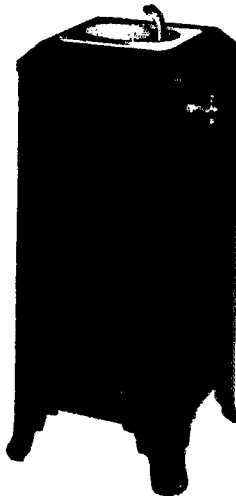

new water cooler model known as 3-I-M. To provide maximum sanitation it is equipped with an angle type bubbler, having a mouth guard. It has a hinged top on which the receptor and bubbler are installed. This is accomplished through the use of flexible metal tubing in the connection between the bubbler and water coils. When re-icing, the top is merely turned back.

With the bubbler on the top, it is at a convenient height for drinking. It also permits a neat, compact unit. Built of furniture steel and finished in bronze Sun-glow lacquer, with the receptor of vitreous porcelain enamel, this model is a very attractive unit for offices or small service or retail establishments.

The bubbler is a self-regulating angle type, insuring a steady drinking stream. Coils are copper, tinned both inside and outside. Inside of the cabinet is car steel hot galvanized around 2 inches of approved insulation. Capacity at first icing is approximately 40 pounds of chipped ice.

For production departments having excessive heat, this company offers insulated coolers built especially for the purpose.

## Wilson Screwless Shock Proof Portable Lamp Guards

The Safeguard Electric Company, 30 Church Street, New York City, announces

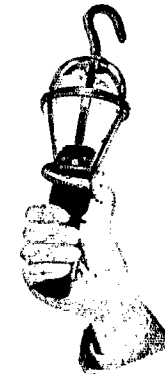

a shock proof portable lamp guard. It is furnished in two patterns, one with fibre guards and the other with metal guards. The first consists of heavy fibre strips and rings, solid fibre hooks, fibre reflectors. The manufacturers claim it can be hung on live bars without danger of shocks to the men or short circuits to the machinery. The second consists of metal guards electrically welded with No. 10 steel wire, with heavy gage metal reflectors, and all parts cadmium plated. A swivelled friction hook holds the lamp guard in position.

Both types are equipped with oil-resistant composition handles that have extra heavy walls, of easy gripping, non-slipping design. The handle is arranged for rapid wiring of the extension cord, which passes through the bottom seal, the strain washer, and connects directly to the socket. No taping or soldering is required. The handle seals the cord at the bottom, also cushions and seals the lamp bulb at the top. The guards are secured to the handle with a 9/16 inch solid rubber oil-resistant ring.

## Beg Pardon

The new Davis Brac-Kit, which is a first aid kit within a kit, announced in the October issue showed the illustration upside down. This kit is mounted on the wall as shown herewith. The Davis Emergency Equipment Company, 55 Van Dam Street, New York, state the advantages of this type of kit are that the first aid kit remains always available in the same place. The container is attached to the wall. The kit itself, in 20 gage steel case, may be removed from the container by a twist of the handle on the bottom. This handle is also used to carry the kit.

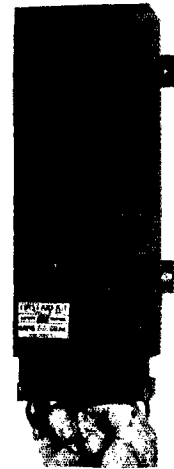

NATIONAL SAFETY NEWS

### Lammert Control Valves

The control or automatic shut-off valve illustrated, embodies a number of new features and refinements which include: few parts; extremely compact; large capacity; simple design and construction; interchangeable elements for air control, steam-pressure control, water-pressure control or electrical control. Valves can be adapted to automatic operation, to remote control, or to automatic operation plus an interlock with manual-reset device.

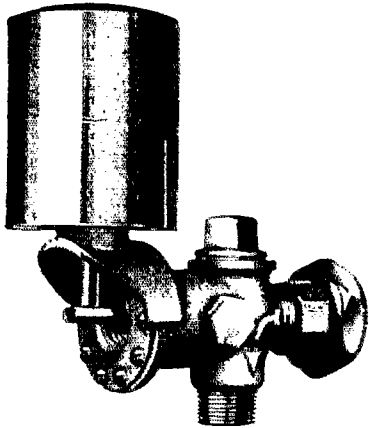

The operating lever, which is actuated by the control device, transmits the force to lift the needle valve. A packless gland in the form of a brass bellows is used to prevent sticking and to give a perfect seal.

The interlock and manual-reset device is a latch-and-weight arrangement which holds the valve in position after it has closed, until the weight has been reset manually. The air-control mechanism is of the piston type, and a pressure of 3 to 50 pounds may be used. The air-operated valve is used on oil burners of the air-atomizing type. In the steam or hydraulic control, the pressure operates through a bellows. The steam-oil and air-oil interlocks are used on industrial oil burners where the atomizing agent (either steam or air) and the oil are supplied by separate units. If the steam or air fails, the oil supply is immediately shut-off, locked shut, and cannot be started until released by hand. The electrical control is through an electro magnet, and the spring which closes the valve is entirely separated from the fluid. It is fully enclosed, but easily accessible upon removing the metal-cup cover. The electrically-operated valve is used for remote control of any liquid—oil, water, brine, etc.

With any of the type of control mentioned, these valves will, it is claimed, handle the heaviest and most viscous oil without sticking.

Lammert liquid-control or automatic shut-off valves are made by Lammert & Mann Company, 248 N. Wood Street, Chicago. They are made in standard sizes from 1/2 inch up.

### NEWS ITEM

Newton Engineering Service announce that after October 15, they will be in their new location at 379 Wilson Avenue, West Bend, Wis. This firm was formerly located in Waukesha, Wis.

Statements published on this page are based on the claims of the manufacturer. While the National Safety News cannot guarantee these statements, they are believed to be accurate.

NOVEMBER, 1935

## Trade Publications

for your

# SAFETY EQUIPMENT LIBRARY

### Information You Should Have

All of these booklets contain many valuable facts on controlling accidents and promoting efficiency. Industrial executives should avail themselves of this fund of information—because along with "safe operation" goes its close friend "profitable operation." Check those you would like and mail the coupon right now!

1. **Safety Guard Protection.** This interesting folder illustrates and describes a multiple controlled triple interlock non-repeat safety guard for punch presses. Designed to protect the operator but not to interfere with production. Junkin Safety Appliance Company.
2. **Pittsburgh Glorified Light Products.** The science of seeing is aptly discussed in this splendid 32-page booklet. Also deals with the cost of seeing, economics of seeing, adequate light, proper lighting, paint, etc. Pittsburgh Plate Glass Company.
3. **M.S.A. Carbon Monoxide Indicator.** Bulletin No. DS-1. This interesting bulletin deals with a portable instrument designed to indicate the low concentrations of carbon monoxide in air, which are recognized as dangerous. Mine Safety Appliances Company.
4. **Weld It Well Bulletin No. HW-4.** This 24-page bulletin covers the complete line of P&H-Hansen arc welders from 50 to 800-ampere units as well as welding fixtures and accessories. Harnischfeger Corporation.
5. **Safetex Gloves and Work Clothes.** This little folder deals with a new protection against acids and other chemicals for industrial workers. Safetex Company, Inc.
6. **Permite Six Foot Cast Bronze Bars.** This 26-page booklet contains valuable data on the uses and properties of various bronze alloys. Graphs show the behavior of the alloys as contents of different metals are altered. Joseph T. Ryerson and Son, Inc.
7. **Electric Heating Data Book. No. 236.** Illustrates and describes space heating by electromode forced heat, gives cost comparisons, illustrates applications of electromode industrial, portable and "Bilt-in-Wall" all electric fan type unit heaters. Electric Air Heater Company, Div. American Foundry Equipment Company.
8. **Fire Alarm Systems, Etc.** A four-page condensed catalogue for quick reference on automatic fire alarm and sprinkler supervisory and hold up alarm systems. For use in industrial plants, schools, hospitals, hotels, institutions, etc. The Gamewell Company.
9. **Ivanhoe Reflectors.** These loose leaf catalog sheets illustrate and describe special types of reflectors for use with high intensity mercury vapor lamps. Designed to produce correct color quality to illumination for uniform production. The Miller Company.
10. **Wilson Portable Lamp Guards.** Four page folder on special screwless shock proof portable lamp guards for use wherever a portable lamp is needed. Shows features of construction. Safeguard Electric Company.
11. **Propellair Fans.** This interesting folder shows several types of fans for industrial ventilating and exhausting. These fans are adapted to the peculiar uses of industry. Propellair, Inc.
12. **Industrial Eye Protection.** Catalog No. 35. This new 28-page catalog illustrates and describes a complete line of goggles for all industrial purposes. Also tells how goggles may be used to cut production costs. American Optical Company.

### NATIONAL SAFETY NEWS

20 North Wacker Drive  
Chicago, Ill.

Please have sent to me the publications I have checked:

Name .....  
 Title .....  
 Company .....  
 Address .....

November, 1935

**TRICO**

**FUSE PULLERS**

"A lifetime of Safety First service"

Eliminates shocks, burns or possible death. \* \* \*

The standard of America's leading Safety Engineers. \* \* \* \* \*

Made in 4 sizes

Write for literature

**TRICO FUSE MFG. CO.**  
Dept. S. Milwaukee, Wis.

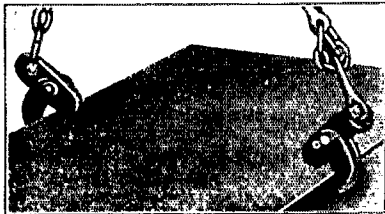

## Save Time and Money In Handling Boiler Plate

IT'S expensive to handle boiler plate with old-fashioned chains and hooks, which have a tendency to slip, causing accidents.

The use of Never Slip Safety Clamps will reduce these expenses, because these clamps do not slip. Two clamps and chains will do the work of four bent hooks and chains, and do it without harming the plate. Even at an angle, Never Slip Clamps will hold work without slipping. Made in two styles for lifting plates horizontally and vertically.

Write for details

**Never Slip Safety Clamp Co.**  
P. O. Box 448  
Grand Central Annex, New York City

## Hydrogen Sulphide

(Continued from page 36)

occur after a few seconds inhalation of a high concentration and results in panting respiration, pallor, cramps, paralysis of the pupil, and almost immediate loss of consciousness with loss of speech and no other warning than a cry. Death may occur with extreme rapidity from respiratory and cardiac paralysis. Even deep sniffing of a sufficiently high concentration may cause the latter effects.

6. In Table A is shown the toxicity of hydrogen sulphide to men exposed to various concentrations for varying periods. The data contained therein have been compiled from work done by the United States Bureau of Mines and other authorities.

### Treatment

7. Hydrogen sulphide often acts so quickly on the lungs when breathed that there is no time to call a doctor before beginning to revive the victim. The following things should be done in the order named:

- Move the victim at once into fresh, pure air.
- If victim is unconscious and not breathing, immediately apply the Schaefer prone pressure method of artificial respiration and continue it without interruption until natural breathing is restored or until rigor mortis (stiffening of the body at death) sets in.
- Summon a doctor.
- If available, give oxygen mixed with 5 per cent carbon dioxide, through an inhaling apparatus. (Not a lung motor.)

### Precautions

8. The following precautions should be strictly observed whenever the presence of hydrogen sulphide is known or suspected:

- Maximum care should be taken to prevent the escape of fumes into the air of working places by leaks, etc.
- Installation of adequate ventilation systems. (See Note X.)
- Before entering air suspected of containing hydrogen sulphide, make sure that a test has been made to determine whether or not the gas is present.
- Never enter a tank, cellar or other enclosed place where the gas has accumulated without wearing proper respiratory protection equipment and a safety belt secured to a life line held by another person outside. (See Note Y.)
- Do not try to determine the presence of the gas by its odor. (See Note Z.)

NOTE W: See Bureau of Mines Report of Investigation 5276 for a detailed description of a detector for quantitative estimate of low concentrations of hydrogen sulphide, and Bureau of Mines Report of Investigation Serial 2847 for a satisfactory method for the determination of hydrogen sulphide by titrating with iodine solution.

NOTE X: For detailed information on ventilation systems, see National Safety Council Safe Practices Pamphlet No. 37, "Industrial Ventilation."

NOTE Y: For detailed information on suitable breathing equipment, see National Safety Council Safe Practices Pamphlet No. 64, "Respirators, Gas Masks, Hose Masks and Breathing Apparatus."

NOTE Z: For additional information on precautions to be taken in the handling and refining of high-sulphur petroleum, see United States Bureau of Mines Report of Investigations Nos. 2847 and 231.

### National Safety Council, Inc.

20 North Wacker Drive  
Chicago, Illinois

STATEMENT OF THE OWNERSHIP, MANAGEMENT, CIRCULATION, ETC., REQUIRED BY THE ACT OF CONGRESS OF AUGUST 24, 1912, OF NATIONAL SAFETY NEWS, published monthly at Chicago, Ill., for October 1, 1935, State of Illinois, County of Cook, ss.

Before me a Notary in and for the State and county aforesaid, personally appeared W. H. Cameron, who, having been duly sworn according to law, deposes and says that he is the business manager of the NATIONAL SAFETY NEWS and that the following is, to the best of his knowledge and belief, a true statement of the ownership, management (and if a daily paper, the circulation), etc., of the aforesaid publication for the date shown in the above caption, required by the Act of August 24, 1912, embodied in section 443, Postal Laws and Regulations, printed on the reverse side of this form, to-wit:

1. That the names and addresses of the publisher, editor, managing editor and business managers are:

Publisher—National Safety Council, Chicago.

Editor—C. T. Fish, Chicago.

Managing Editor—None.

Business Manager—W. H. Cameron, Chicago.

2. That the owners are:

National Safety Council, an association—John E. Long, president, Albany, N. Y.; R. L. Catlin, vice-president, Hartford, Conn.; Lew R. Palmer, vice-president, New York City; R. T. Solensten, vice-president, New York City; Dr. C. H. Watson, vice-president, New York City; C. W. Smith, vice-president, Chicago; D. D. Fennell, vice-president, Chicago; A. W. Whitney, vice-president, New York City; W. E. Worth, vice-president and treasurer, New York City; W. H. Cameron, managing director, Chicago.

3. That the known bondholders, mortgagees, and other security holders owning or holding 1 per cent of more of total amount of bonds, mortgages, or other securities are: None.

4. That the two paragraphs next above giving the names of the owners, stockholders, and security holders, if any, contain not only the list of stockholders and security holders as they appear upon the books of the company, but also, in cases where the stockholder or security holder appears upon the books of the company as a trustee or in any other fiduciary relation, the name of the person or corporation for whom such trustee is acting, is given; also that the said two paragraphs contain statements embracing affiant's full knowledge and belief as to the circumstances and conditions under which stockholders and security holders who do not appear upon the books of the company as trustees, hold stock and securities in a capacity other than that of a bonafide owner; and this affiant has no reason to believe that any other person, association or corporation has any interest direct or indirect in the said stock, bonds, or other securities than as so stated by him.

W. H. CAMERON,

Managing Director.  
Sworn to and subscribed before me this 21st day of September, 1935.

MYRTLE H. MOLLAN,  
Notary Public.

My commission expires September 18, 1936.

NATIONAL SAFETY NEWS

# AMERICAN MASON SAFETY TREADS

Abrasive  
Iron  
Bronze  
Aluminum  
Nickel

Formerly known as "Carbo-Cast"



Fluted

Diamond  
Hatched

Plain

The carborundum or aluminous abrasive embedded in these stair treads is an integral part of the body metal. The flint like particles project above the surface, producing a surface that effectively prevents slipping whether wet or dry.

Over 40 years Experience is at  
your service for the asking

## AMERICAN MASON SAFETY TREAD CO.

Lowell, Massachusetts  
Distributed By  
Joseph T. Ryerson & Son, Inc.  
Chicago, Illinois

# Stonehouse

SIGNS  
for  
ACCIDENT PREVENTION

New Catalog No. 4 is yours for  
the asking.

May we send it today?



STONEHOUSE SIGNS, Inc.  
Stonehouse Building  
418 at Larimer  
Denver, Colo.



NOVEMBER, 1935

## INDEX TO ADVERTISERS

Accident Prevention Equipment Manufacturer's Section .....	76-77-78
American Abrasive Metals Co. ....	56
American Mason Safety Tread Co. ....	75
American Optical Co. ....	8
Bernhard, Robert A. ....	65
Bishinger-Koehler Mfg. Co., Inc. ....	64
Bradley Washfountain Company ....	61
Breuer Electric Mfg. Co. ....	58
Brown Shoe Co. ....	59
Bullard Company, E. D. ....	57
Burroughs Wellcome & Co. (U.S.A.) Inc. ....	7
Buxbaum Company, The ....	61
Carnegie-Illinois Steel Corp. ....	4
Chicago Eye Shield Co. ....	53
Cities Service ....	63
Clements Mfg. Co. ....	71
Cover, H. S. ....	51
Davis Emergency Equipment Co. ....	59-65-69
Dayton Safety Ladder Co. ....	68
Dracco Corporation ....	68
Ellwood Safety Appliance Co. ....	71
General Abrasive Co. ....	67
Harker Mfg. Co. ....	70
Harrington & King Perforating Co. ....	52
Hynson, Westcott & Dunning, Inc. ....	37
Inclinor Company ....	71
Industrial Gloves Corp. ....	67
Industrial Products Company ....	68
International Shoe Co. ....	51
Invincible Vacuum Cleaner Mfg. Co. ....	62
Junkin Safety Appliance Co. ....	66
Justrite Mfg. Co. ....	66
Kidde Co., Inc. Walter ....	49
Klein & Sons, Mathias ....	54
Lehigh Safety Shoe Co., Inc. ....	56
Libbey-Owens-Ford Glass Co. ....	5
Lima Cord Sole & Heel Co. ....	58
Mac-white Company ....	48
Matthews & Co., Jas. H. ....	62
Mine Safety Appliances Co. ....	Inside Front Cover
National Safety Council, Inc. ....	2-38-39
Never Slip Safety Clamp Co. ....	74
Pangborn Corporation ....	55
Procter & Gamble Co. ....	3
Proppellair, Inc. ....	53
Pulmesan Safety Equipment Corp. ....	Inside Back Cover
Pyrol Co. ....	67
Safeguard Electric Co. ....	52
Safety Clothing Co. ....	57
Safety Equipment Service Co. ....	Back Cover
Safety First Shoe Co., The ....	55
Spencer Turbine Co. ....	64
Stonehouse Signs, Inc. ....	75
Trico Fuse Mfg. Co. ....	74
Trumbull Manufacturing Co. ....	63
West Disinfecting Co. ....	75
Williams & Co., J. H. ....	67
Willson Products, Inc. ....	1

### MISJUDGED

Here lies a pedestrian  
Cold as ice.  
He jumped only once  
When he should have jumped twice.

# RESULTS NEVER POSSIBLE BEFORE!

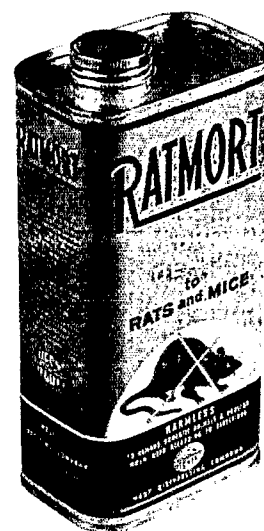

Rats cannot live if they nibble only a small part of RATMORT bait. RATMORT causes rodents to rush outside for air, eliminating the danger of decaying carcasses on the premises.

RATMORT, harmless to humans and domestic animals, is a concentrated extract of red squill, which is approved and recommended by the U. S. Dept. of Agriculture. Its use is officially permitted in dairies, groceries and other food depots.

SEND  
FOR  
FREE  
BOOKLET

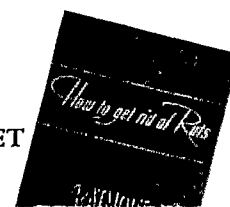

### WEST DISINFECTING CO.

42-16 BARN ST., LONG ISLAND CITY, N. Y.  
Branches in Principal Cities  
Leading manufacturer of insecticides and disinfectants for half a century. Write us for advice on your particular problem.

# THE BUYERS' SERVICE

See Advertisers' Index, Page 75—When writing, please mention National Safety News

**A**  
**Accident Prevention Service**  
National Safety Council, Inc.

**Alarms, Fire**  
Mine Safety Appliances Co.

**Anemometers**  
Bullard Company, E. D.  
Mine Safety Appliances Co.  
Portable Lamp & Equipment Co.

**Aprons**  
Bullard Company, E. D.  
Davis Emergency Equipment Co., Inc.  
Industrial Gloves Corp.  
Industrial Products Co.  
Mine Safety Appliances Co.  
Panborn Corp.  
Pulmonan Safety Equipment Corp.  
Safety Clothing Co., The  
Safety Equipment Service Co., The  
Safety First Supply Co.  
Standard Safety Equipment Co.  
Strauss Company, The

**Arrestors, Dust**  
Bullard Company, E. D.  
Draceo Corporation  
Panborn Corp.  
Surtz Mfg. Co., The

**Awards, Prize**  
Matthews & Co., Jas. H.  
Mine Safety Appliances Co.

**B**  
**Badges and Buttons**  
Bullard Company, E. D.  
Mine Safety Appliances Co.

**Bags, Tool, Linemen**  
Bahrke Company, R. H.  
Bullard Company, E. D.  
Davis Emergency Equipment Co., Inc.  
Industrial Products Co.  
Safety Equipment Service Co., The  
Sahsbury & Co., W. H.  
Strauss Company, The

**Belts, Linemen**  
Bahrke Company, R. H.  
Bullard Company, E. D.  
Davis Emergency Equipment Co., Inc.  
Industrial Products Co.  
Klein & Sons, Mathias  
Mine Safety Appliances Co.  
Portable Lamp & Equipment Co.  
Pulmonan Safety Equipment Corp.  
Safety Clothing Co., The  
Safety Equipment Service Co., The  
Safety First Supply Co.  
Standard Safety Equipment Co.  
Strauss Company, The

**Belts, Safety**  
Bahrke Company, R. H.  
Bullard Company, E. D.  
Davis Emergency Equipment Co., Inc.  
Industrial Products Co.  
Klein & Sons, Mathias  
Mine Safety Appliances Co.  
Portable Lamp & Equipment Co.  
Pulmonan Safety Equipment Corp.  
Safety Clothing Co., The  
Safety Equipment Service Co., The  
Safety First Supply Co.  
Standard Safety Equipment Co.  
Strauss Company, The

**Belts, Tree Trimming**  
Bahrke Company, R. H.  
Bullard Company, E. D.  
Industrial Products Co.  
Mine Safety Appliances Co.  
Strauss Company, The

**Belts, Window Cleaning**  
Bahrke Company, R. H.  
Bullard Company, E. D.  
Industrial Products Co.  
Mine Safety Appliances Co.

**Blowers, Hose Mask**  
Bullard Company, E. D.  
Davis Emergency Equipment Co., Inc.

**Blowers, Portable, Electric**  
Bremer Electric Mfg. Co.  
Clematis Mfg. Co.  
Panborn Corp.  
Sencer Turbine Co.  
Surtz Mfg. Co., The

**Davis Emergency Equipment Co., Inc.**  
Industrial Products Co.  
Justite Mfg. Co.  
Mine Safety Appliances Co.  
(Protectors) Company  
Pulmonan Safety Equipment Corp.  
Safety Equipment Service Co., The  
Standard Safety Equipment Co.

**Chain, Factory**  
McKay Company

**Davis Emergency Equipment Co., Inc.**  
Industrial Gloves Corp.  
Industrial Products Co.  
Mine Safety Appliances Co.  
Safety Clothing Co., The  
Safety Equipment Service Co., The  
Safety First Supply Co.  
Standard Safety Equipment Co.  
Strauss Company, The

**Clothing, Weatherproof**  
Bullard Company, E. D.  
Davis Emergency Equipment Co., Inc.  
Industrial Gloves Corp.  
Industrial Products Co.  
Mine Safety Appliances Co.  
Safety Clothing Co., The  
Safety Equipment Service Co., The  
Safety First Supply Co.  
Standard Safety Equipment Co.

**Cloths, Wiping**  
Sanitary Institute of America

**Collectors, Dust**  
Draceo Corporation  
Panborn Corp.  
Surtz Mfg. Co., The

**Compounds, Fireproofing**  
Sleepsafe Industries, Inc.

**Compounds, Cleaning**  
Safety Clothing Co., The

**Containers, Explosive Liquid**  
Bullard Company, E. D.  
Davis Emergency Equipment Co., Inc.  
Industrial Products Co.  
Justite Mfg. Co.  
Mine Safety Appliances Co.  
Portable Lamp & Equipment Co.  
Protector Company  
Safety Equipment Service Co., The  
Strauss Company, The

**D**  
**Detectors, Gas**  
Bullard Company, E. D.  
Davis Emergency Equipment Co., Inc.  
Mine Safety Appliances Co.  
Portable Lamp & Equipment Co.

**Detectors, Indicators, Recorders, Carbon Monoxide**  
Bullard Company, E. D.  
Davis Emergency Equipment Co., Inc.  
Mine Safety Appliances Co.

**Detectors, Pyrotanic**  
Mine Safety Appliances Co.

**Disinfectants and Deodorants**  
West Disinfecting Co.

**Dust Camera**

**Dusters, Rock**  
Mine Safety Appliances Co.  
Portable Lamp & Equipment Co.

**E**  
**Emblems, Safety**  
Mine Safety Appliances Co.

**Exhausts, Grinding Wheel**  
Surtz Mfg. Co., The

## Falls From Ladders— Avoid Them

The New York State Department of Labor reports show that for a period of three years there were 5,540 compensated cases caused by falls from ladders. The total compensation paid for these claims amounted to \$2,750,185.00.

Safety ladders properly used would have prevented many of these accidental injuries. Be sure your ladder equipment is in good condition, and that your workers are instructed in the correct use of ladders.



**Portable Lamp & Equipment Co.**  
Safety Clothing Co., The  
Strauss Company, The

**Blankets, Fireproof**  
Bullard Company, E. D.  
Davis Emergency Equipment Co., Inc.  
Industrial Products Co.  
Mine Safety Appliances Co.  
Pulmonan Safety Equipment Corp.  
Safety Clothing Co., The  
Safety Equipment Service Co., The  
Safety First Supply Co.  
Standard Safety Equipment Co.

**Blockers, Mine Car**  
Industrial Products Co.  
Mine Safety Appliances Co.

**Blockers, Railroad Car**  
Bullard Company, E. D.  
Industrial Products Co.  
Safety Equipment Service Co., The  
Safety First Supply Co.  
Standard Safety Equipment Co.

**Buckets, Hoisting**  
Bullard Company, E. D.  
Davis Emergency Equipment Co., Inc.  
Industrial Products Co.

**Bulletin Boards**  
Bullard Company, E. D.  
Davis Emergency Equipment Co., Inc.  
Elliott Service Co.  
Mine Safety Appliances Co.  
Pulmonan Safety Equipment Corp.  
Safety Equipment Service Co., The  
Safety First Supply Co.  
Standard Safety Equipment Co.

**Cans, Oil**  
Bullard Company, E. D.  
Industrial Products Co.  
Mine Safety Appliances Co.  
Panborn Corp.  
Safety Equipment Service Co., The

**Cans, Waste**  
Bullard Company, E. D.

**Chairs, Safety, Roustswain**  
Bullard Company, E. D.  
Mine Safety Appliances Co.  
Strauss Company, The

**Clamps, Rail**  
Industrial Products Co.  
Safety Clothing Co.  
Safety First Supply Co.

**Clamps and Sockets**  
Safety First Supply Co.

**Cleaning Systems, Vacuum**  
Bremer Electric Mfg. Co.  
Clematis Mfg. Co.  
Inventive Vacuum Cleaner Mfg. Co.  
Sencer Turbine Co.  
Surtz Mfg. Co., The

**Clothing for Industrial Workers—See Aprons, Gloves, Hand Leathers, Leggings, Shoes**

**Clothing, Acidproof**

**Clothing, Fireproof**  
Bullard Company, E. D.

NATIONAL SAFETY NEWS

# THE BUYERS' SERVICE

See Advertisers' Index, Page 75—When writing, please mention National Safety News

- Exterminator, Rodent**  
West Disinfecting Co.
- Extinguishers, Fire**  
Bullard Company, E. D.  
Harker Mfg. Co.  
Kidde & Co., Inc., Walter  
Mine Safety Appliances Co.  
Portable Lamp & Equipment  
Co.  
Pulmosan Safety Equipment  
Corp.  
Pyrene Mfg. Company
- F**
- Fans, Exhaust**  
Draccon Corporation  
Pangborn Corporation  
Propellair, Inc.  
Sury Mfg. Co., The
- Fasteners or Lacers, Belt**  
Clipper Belt Lacer Co.
- Films or Slides, Safety, for Rent and Sale**  
National Safety Council, Inc.
- First Aid Equipment**  
Abbott Laboratories  
Bauer & Black  
Brenthard, Robert A.  
Bushing-Koehler Mfg. Co.,  
Inc.  
Bullard Company, E. D.  
Burroughs-Wellcome Co.,  
(U.S.A.) Inc.  
Davis Emergency Equipment  
Co., Inc.  
Hynson, Westcott & Dunmore,  
Inc.  
Industrial Products Co.  
Johnson & Johnson  
Merck & Company  
Mine Safety Appliances Co.  
Pulmosan Safety Equipment  
Corp.  
Safety Clothing Co.  
Safety Equipment Service  
Co., The  
Safety First Supply Co.  
Standard Safety Equipment Co.
- Flags, Danger**  
Bullard Company, E. D.  
Industrial Products Co.  
Safety Equipment Service  
Co., The  
Stonehouse Signs, Inc.
- Flashlights, Permissible**  
Bullard Company, E. D.  
Portable Lamp & Equipment  
Co.
- Floor Cleaning  
Machines, Electric**
- Flooring Material,  
Safety**  
American Abrasive Metals Co.  
American Mason Safety Treat-  
Co.  
Carnegie-Illinois Steel Corp.  
Central Abrasive Co.  
Illinois Steel Company  
Industrial Products Co.  
Inland Steel Co.  
Safety First Supply Co.  
Sury Mfg. Co., The
- Footwear, Rubber**  
Bullard Co., E. D.  
Industrial Products Co.  
Lehigh Safety Shoe Co.  
Mine Safety Appliances Co.  
Portable Lamp & Equipment  
Co.
- Fountains, Drinking,  
Factory**  
Bradley Washfontains Co.
- Fumigants**  
Bauer & Black
- G**
- Germicides**
- Germicides, Cutting Oil**  
West Disinfecting Co.
- Glass, Safety**  
American Optical Company  
Bullard Company, E. D.

- Chicago Eye Shield Co.  
Industrial Products Co.  
Abbey-Owens-Ford Glass Co.  
Mine Safety Appliances Co.  
Pittsburgh Plate Glass Co.  
Safety Clothing Co., The  
Safety Equipment Service  
Co., The  
Standard Safety Equipment Co.  
Sury Mfg. Co., The  
Wilson Products, Inc.

- Gloves and Mittens**  
Bullard Company, E. D.  
Chicago Eye Shield Co.  
Davis Emergency Equipment  
Co., Inc.

- Gongs, Sirens, Horns  
and other Signaling  
Devices**  
Bullard Company, E. D.  
Industrial Products Co.  
Mine Safety Appliances Co.
- Gratings, Safety**
- Guards, Chip and Spark**  
Bullard Company, E. D.  
Chicago Eye Shield Co.  
Industrial Products Co.  
Safety Clothing Co., The  
Safety Equipment Service  
Co., The  
Standard Safety Equipment Co.

- Guards, Kick Press**  
Sury Mfg. Co., The
- Guards, Portable Lamp**  
Safeguard Electric Co.
- Guards, Power Press**  
Chicago Eye Shield Co.  
Industrial Products Co.  
Junkin Safety Appliance Co.  
Standard Safety Equipment Co.  
Sury Mfg. Co., The
- Guards, Safety**  
Bullard Company, E. D.  
Davis Emergency Equipment  
Co., Inc.

- Mine Safety Appliances Co.  
Portable Lamp & Equipment  
Co.  
Safety Clothing Co., The  
Safety First Supply Co.  
Strauss Company, The
- Heat Cramp Preventives**  
Fairway Laboratories, Inc.
- Helmets, Safety**  
American Optical Company  
Bushing-Koehler Mfg. Co.,  
Inc.  
Bullard Company, E. D.  
Chicago Eye Shield Co.  
Davis Emergency Equipment  
Co., Inc.  
Industrial Products Co.  
Mine Safety Appliances Co.  
Pangborn Corporation  
Portable Lamp & Equipment  
Co.  
Pulmosan Safety Equipment  
Corp.  
Safety Clothing Co., The  
Safety Equipment Service  
Co., The  
Safety First Supply Co.  
Standard Safety Equipment Co.  
Wheeler Mfg. Co., E. H.  
Wilson Products, Inc.

## There is Proper Equip- ment for Every Hazard

A large company was having trouble with men get-  
ting sick from naphtha fumes while cleaning out  
tanks. It was discovered they were using the wrong  
type of protective equipment. When this condition  
was corrected the men showed no ill effects from the  
cleaning operation and were able to do this job in  
half the time usually taken.

Manufacturers of respiratory equipment have com-  
petent men to consult with you on the type of device  
best suited to protect against specific hazards.



- Industrial Gloves Corp.**  
Industrial Products Co.  
Mine Safety Appliances Co.  
Pangborn Corporation  
Pulmosan Safety Equipment  
Corp.  
Safety Clothing Co., The  
Safety Equipment Service  
Co., The  
Safety First Supply Co.  
Sullivan & Co., W. H.  
Standard Safety Equipment Co.  
Wheeler Mfg. Co., E. H.

- Goggles**  
American Optical Company  
Bullard Company, E. D.  
Chicago Eye Shield Co.  
Cover, H. S.  
Davis Emergency Equipment  
Co., Inc.  
Industrial Products Co.  
Mine Safety Appliances Co.  
Portable Lamp & Equipment  
Co.  
Pulmosan Safety Equipment  
Corp.  
Safety Clothing Co., The  
Safety Equipment Service  
Co., The  
Safety First Supply Co.  
Standard Safety Equipment Co.  
Wilson Products, Inc.

- Guards, Flywheel**  
Harrison & King Perforat-  
ing Co.  
Industrial Products Co.  
Safety Clothing Co., The  
Safety Equipment Service  
Co., The  
Sury Mfg. Co., The
- Guards, Foot and Toe**  
Bullard Company, E. D.  
Davis Safety Appliance Co.  
Industrial Products Co.  
Mine Safety Appliances Co.  
Portable Lamp & Equipment  
Co.  
Safety Clothing Co., The  
Safety Equipment Service  
Co., The  
Safety First Supply Co.  
Standard Safety Equipment Co.  
Strauss Company, The
- Guards, Gear**  
Sury Mfg. Co., The
- Guards, Grinding Wheel**  
Sury Mfg. Co., The
- Guards, Jointer**  
Industrial Products Co.  
Safety Equipment Service  
Co., The  
Standard Safety Equipment Co.  
Sury Mfg. Co., The

- Harrison & King Perforat-  
ing Co.  
Industrial Products Co.  
Safety Clothing Co., The  
Safety Equipment Service  
Co., The  
Sury Mfg. Co., The
- Guards, Saw**  
Bullard Company, E. D.  
Industrial Products Co.  
Safety Equipment Service  
Co., The  
Standard Safety Equipment Co.  
Sury Mfg. Co., The
- Guards, Shopper**  
Industrial Products Co.  
Standard Safety Equipment Co.  
Sury Mfg. Co., The
- Guards, Treadle**  
Sury Mfg. Co., The
- H**
- Hand Cream**  
Bullard Company, E. D.  
Davis Emergency Equipment  
Co., Inc.  
Industrial Products Co.  
Mine Safety Appliances Co.  
Safety Clothing Co.
- Hats, Safety**  
Bullard Company, E. D.  
Industrial Products Co.

- Hoists, Electric**
- Hooks, Safety Belt**  
Bullard Company, E. D.  
Davis Emergency Equipment  
Co., Inc.  
Industrial Products Co.  
Mine Safety Appliances Co.  
Portable Lamp & Equipment  
Co.  
Safety Equipment Service  
Co., The  
Strauss Company, The
- Hooks, Safety, Hoisting**  
Industrial Products Co.
- Hospital Equipment**  
Bullard Company, E. D.  
Burroughs-Wellcome Co.,  
(U.S.A.) Inc.  
Davis Emergency Equipment  
Co., Inc.  
Industrial Products Co.  
Mine Safety Appliances Co.  
Safety Equipment Service  
Co., The  
Safety First Supply Co.
- I**
- Inclinators, Carboy**  
Bullard Company, E. D.  
Inclinator Company  
Industrial Products Co.  
Safety Clothing Co.  
Safety Equipment Service  
Co., The
- Indicators, Flammable  
Vapor**  
Bullard Company, E. D.  
Davis Emergency Equipment  
Co., Inc.  
Mine Safety Appliances Co.
- Inhalators**  
Bushing-Koehler Mfg. Co.,  
Inc.  
Bullard Company, E. D.  
Davis Emergency Equipment  
Co., Inc.  
Mine Safety Appliances Co.
- Insurance**  
Metropolitan Life Insurance  
Co.
- Interlock Systems**  
Cotton Switch & Supply Co.
- J**
- L**
- Ladder Shoes or Feet**  
American Abrasive Metals Co.  
American Mason Safety Treat-  
Co.  
Bullard Company, E. D.  
Davis Emergency Equipment  
Co., Inc.  
Dayton Safety Ladder Co.  
Industrial Products Co.  
Mine Safety Appliances Co.  
Patent Sealing Co., The  
Safety Clothing Co., The  
Safety First Supply Co.  
Sury Mfg. Co., The
- Ladders, Safety**  
Bullard Company, E. D.

# THE BUYERS' SERVICE

See Advertisers' Index, Page 75—When writing, please mention National Safety News

**Hayton Safety Ladder Co.**  
Mine Safety Appliances Co.  
Patent Scaffolding Co., The  
Safety First Supply Co.

## Lamps, Safety

Benjamin Electric Mfg. Co.  
Bullard Company, E. D.  
Davis Emergency Equipment Co., Inc.  
Mine Safety Appliances Co.  
Portable Lamp & Equipment Co.

## Lanterns, Carbide

Bullard Company, E. D.

## Lanterns, Electric

Bullard Company, E. D.  
Industrial Products Co.  
Jutric Mfg. Co.  
Mine Safety Appliances Co.  
Portable Lamp & Equipment Co.

## Leathers, Hand

Bullard Company, E. D.  
Industrial Gloves Corp.  
Industrial Products Co.  
Pulmonan Safety Equipment Corp.  
Safety Clothing Co., The  
Safety Equipment Service Co., The  
Safety First Supply Co.  
Standard Safety Equipment Co.  
Strauss Company, The

## Leggings

Bullard Company, E. D.  
Davis Emergency Equipment Co., Inc.  
Industrial Gloves Corp.  
Industrial Products Co.  
Mine Safety Appliances Co.  
Pulmonan Safety Equipment Corp.  
Safety Clothing Co., The  
Safety Equipment Service Co., The  
Safety First Supply Co.  
Standard Safety Equipment Co.  
Strauss Company, The

## Lighting Equipment, Industrial

Benjamin Electric Mfg. Co.  
Westinghouse Electric & Mfg. Co.

## Lockers and Hangers for Clothing

Industrial Products Co.

## Locks, Lamp

Industrial Products Co.  
Mine Safety Appliances Co.  
Safety Equipment Service Co., The

## Locks, Locker and Padlock, Keyless

Dudley Lock Corp.

## Lubrication

Pvroll Company

## M

## Machines, Floor Cleaning, Electric

## Markers, Traffic

Safety Equipment Service Co., The

## Masks

American Optical Company  
Bishinger-Koehler Mfg. Co., Inc.  
Bullard Company, E. D.  
Chicago Eye Shield Co.  
Davis Emergency Equipment Co., Inc.  
Industrial Products Co.  
Mine Safety Appliances Co.  
Pangborn Corp.  
Pulmonan Safety Equipment Corp.  
Safety Clothing Co., The  
Safety Equipment Service Co., The  
Safety First Supply Co.  
Standard Safety Equipment Co.  
Wilson Products, Inc.

## Mats, Standing, Safety

Bullard Company, E. D.  
Ruzbaum Co.  
Davis Emergency Equipment Co., Inc.  
Industrial Products Co.  
Safety First Supply Co.

## Mattress, Fireproof

Sleepsafe Industries, Inc.

## Metal, Expanded

Surdy Mfg. Co., The

## Metal, Perforated

Harrington & King Perforating Co.

Safety Equipment Service Co., The  
Safety First Supply Co.

## Poster Service

Billett Service Co.  
National Safety Council, Inc.  
Bullard Company, E. D.  
Chicago Eye Shield Co.  
Davis Emergency Equipment Co., Inc.  
Industrial Products Co.  
Mine Safety Appliances Co.

## Protectors, Arm

Bullard Company, E. D.  
Davis Emergency Equipment Co., Inc.

Safety First Supply Co.  
Sallisbury & Co., W. H.  
Standard Safety Equipment Co.

## Publications, Safety

National Safety Council, Inc.  
Safety Magazine Publishing Corp.

## Pullers, Fuse

Bullard Company, E. D.  
Industrial Products Co.  
Mine Safety Appliances Co.  
Safety Equipment Service Co., The  
Trico Fuse Mfg. Co.

Bullard Company, E. D.  
Davis Emergency Equipment Co., Inc.  
Mine Safety Appliances Co.

## Rope, Wire

Macwhyle Company

## S

## Scaffolding, Safety

Patent Scaffolding Co., The

## Screw Drivers, Non-skid

Surdy Mfg. Co., The

## Shades, Eye, Non-breakable

Bullard Company, E. D.  
Chicago Eye Shield Co.  
Davis Emergency Equipment Co., Inc.  
Industrial Products Co.  
Mine Safety Appliances Co.  
Safety Clothing Co.  
Safety Equipment Service Co., The

## Shades, Window, Industrial

## Shoes, Safety, Factory and Foundry

Brown Shoe Company  
Bullard Company, E. D.  
Industrial Products Co.  
International Shoe Co.  
Lehigh Safety Shoe Co.  
Mine Safety Appliances Co.  
Portable Lamp & Equipment Co.  
Safety Equipment Service Co., The  
Safety First Shoe Co.  
Safety First Supply Co.

## Shoes, Wooden Sole

Industrial Products Co.  
Safety Clothing Co., The

## Signs, Accident Prevention

Bullard Company, E. D.  
Industrial Products Co.  
Mine Safety Appliances Co.  
Portable Lamp & Equipment Co.  
Safety Clothing Co., The  
Safety Equipment Service Co., The  
Safety First Supply Co.  
Standard Safety Equipment Co.  
Stonehouse Signs, Inc.

## Sirens and Signals

Bullard Company, E. D.  
Industrial Products Co.

## Slings, Safety, Wire Rope

Macwhyle Company

## Soap

Proctor & Gamble Co.

## Soles, Shoe, Non-slip

Luna Cord Sole & Heel Co.

## Sterilizing Equipment

## Straps, Safety

Buhrke Company, R. H.  
Bullard Company, E. D.  
Davis Emergency Equipment Co., Inc.  
Industrial Products Co.  
Klein & Sons, Mathias  
Portable Lamp & Equipment Co.

## Stretcher Units

## Surveys, Eye Sight Systems, Dust Control

Draco Corporation  
Pangborn Corporation  
Surdy Mfg. Co., The

## T

## Tents, Pneumonia

Bishinger-Koehler Mfg. Co., Inc.  
Mine Safety Appliances Co.

## Testers, Fuse

## Tools, Linemen

Bullard Company, E. D.  
Davis Emergency Equipment Co., Inc.  
Industrial Products Co.  
Klein & Sons, Mathias

## Safety Belts Prevent Many Serious Injuries

A workman washing skylights was equipped with a safety belt similar to those worn by professional window washers. While the job was in progress he slipped from a cross member, fell and hung in mid-air 45 feet over a number of flasks of molten metal. His belt saved his life.

A miner was sent to lower a hung-up chute. During the job an accident occurred and had it not been for his safety belt he would have fallen to the level 30 feet below, and possibly an additional 100 feet through an open chute.



Industrial Products Co.

## Movers, Railway Car

Bullard Company, E. D.  
Industrial Products Co.  
Safety Equipment Service Co., The  
Standard Safety Equipment Co.

## O

## Oxygen Breathing Apparatus

Bishinger-Koehler Mfg. Co., Inc.  
Davis Emergency Equipment Co., Inc.  
Mine Safety Appliances Co.

## P

## Pack, Miners'

Lehigh Safety Shoe Co.  
Portable Lamp & Equipment Co.

## Pads, Knee

Bullard Company, E. D.  
Industrial Products Co.  
Industrial Gloves Corp.  
Industrial Products Co.  
Mine Safety Appliances Co.  
Portable Lamp & Equipment Co.

Industrial Gloves Corp.  
Industrial Products Co.  
Mine Safety Appliances Co.  
Pulmonan Safety Equipment Corp.

Safety Clothing Co., The  
Safety Equipment Service Co., The  
Safety First Supply Co.  
Standard Safety Equipment Co.  
Strauss Company, The

## Protectors, Finger

Bauer & Black  
Industrial Gloves Corp.  
Safety Clothing Co., The  
Safety Equipment Service Co., The

## Protectors for Linemen

Bullard Company, E. D.  
Davis Emergency Equipment Co., Inc.  
Industrial Gloves Corp.  
Industrial Products Co.  
Mine Safety Appliances Co.  
Pulmonan Safety Equipment Corp.  
Safety Equipment Service Co., The

## Pumps, Oxygen

Bishinger-Koehler Mfg. Co., Inc.  
Mine Safety Appliances Co.

## R

## Respirators

American Optical Company  
Bishinger-Koehler Mfg. Co., Inc.  
Bullard Company, E. D.  
Chicago Eye Shield Co.  
Cover, H. B.  
Davis Emergency Equipment Co., Inc.  
Industrial Products Co.  
Mine Safety Appliances Co.  
Pangborn Corp.  
Portable Lamp & Equipment Co.  
Pulmonan Safety Equipment Corp.  
Safety Clothing Co., The  
Safety Equipment Service Co., The  
Safety First Supply Co.  
Standard Safety Equipment Co.  
Wilson Products, Inc.

## Reanimation Equipment

Bishinger-Koehler Mfg. Co., Inc.

NATIONAL SAFETY NEWS

# THE BUYERS' SERVICE

See Advertisers' Index, Page 75—When writing, please mention National Safety News

Tools, Marking or Stamping	Treads, Safety	V	W	Wrenches, Hopper Car
Mathews & Co., Jas H.	American Abrasive Metals Co. American Mason Safety Tread Co. Carnegie-Illinois Steel Corp. Illinois Steel Company Industrial Products Co. Inland Steel Co. Surtz Mfg. Co., The	Valves, Oxygen Bishinger-Koehler Mfg. Co., Inc. Mine Safety Appliances Co.	Washers, Safety for Grinding Wheels Industrial Products Co. Standard Safety Equipment Co.	Industrial Products Co. Safety Equipment Service Co., The Safety First Supply Co. Trumbull Mfg. Co., The
Tools, Non-sparking Ampeco Metal, Inc. Bullard Company, E. D. Davis Emergency Equipment Co., Inc. Pulmonan Safety Equipment Corp.	Trestles, Safety, Extension Industrial Products Co. Patent Scaffolding Co., The Safety First Supply Co.	Vending Machines, Sanitary West Disinfecting Co.	Washroom Equipment, Industrial Bradley Washfountain Co. West Disinfecting Co.	Wrenches, Non-Sparking Williams & Co., J. H.
Torches, Blow Klein & Sons, Mathias	Trophies Mathews & Co., Jas H.	Ventilating Equipment Dracco Corporation Pangborn Corporation Propellair, Inc.	Welding Equipment	Wrenches, Pipe Williams & Co., J. H.

The following companies are those whose names appear under the various headings contained in this Buyers' Service

Aubott Laboratories	North Chicago, Ill.	Harker Mfg. Co.	Dayton, O.	Portable Lamp & Equipment Co.	Pittsburgh, Pa.
American Abrasive Metals Co.	Irrington, N. J.	Harrington & King Perforating Co.	Chicago, Ill.	Procter & Gamble Co.	Cincinnati, Ohio
American Mason Safety Tread Co.	Lowell, Mass.	Hynson, Westcott & Dunning, Inc.	Baltimore, Md.	Protocostal Co.	Springfield, Ohio
American Optical Co.	Southbridge, Mass.	Illinois Steel Co.	Chicago, Ill.	Pulmonan Safety Equipment Corp.	Brooklyn, N. Y.
Ampeco Metal Inc.	Milwaukee, Wis.	Inclinator Company	Minneapolis, Minn.	Pyrene Mfg. Co.	Newark, N. J.
Bauer & Black	Chicago, Ill.	Industrial Gloves Corp.	Danville, Ill.	Pyroll Co.	La Crosse, Wis.
Benjamin Electric & Mfg. Co.	Des Plaines, Ill.	Industrial Products Co.	Philadelphia, Pa.	Safeguard Electric Co.	New York, N. Y.
Bernhard, Robert A.	Rochester, N. Y.	Inland Steel Co.	Chicago, Ill.	Safety Clothing Co., The	Cleveland, Ohio
Bishinger-Koehler Mfg. Co.	Pittsburgh, Pa.	International Shoe Co.	St. Louis, Mo.	Safety Equipment Service Co., The	Cleveland, Ohio
Bradley Washfountain Co.	Milwaukee, Wis.	Invincible Vacuum Cleaner Mfg. Co.	Dover, Ohio	Safety First Shoes Co.	Holliston, Mass.
Brewer Electric Mfg. Co.	Chicago, Ill.	Johnson & Johnson	New Brunswick, N. J.	Safety First Supply Co.	Pittsburgh, Pa.
Brown Shoe Company	St. Louis, Mo.	Junkin Safety Appliance Co.	Louisville, Ky.	Safety Magazines Publishing Corp.	New York, N. Y.
Bullock Co., H. H.	Chicago, Ill.	Justice Mfg. Co.	Chicago, Ill.	Sallisbury & Co., Inc., W. H.	Chicago, Ill.
Bullard Co., E. D.	San Francisco, Calif.	Ridd & Co., Inc., Walter	New York, N. Y.	Sanitary Institute of America	Chicago, Ill.
Burrage-Wellcome & Co. (U.S.A.) Inc.	New York, N. Y.	Riehn & Sons, Mathias	Chicago, Ill.	Sleepsafe Industries, Inc.	New York, N. Y.
Burvaugh Company, The	Akron, Ohio	Lehigh Safety Shoe Co.	Allentown, Pa.	Spencer Turbine Co., The	Hartford, Conn.
Carnegie-Illinois Steel Corp.	Pittsburgh, Pa.	Libbey-Owens-Ford Glass Co.	Toledo, Ohio	Standard Safety Equipment Co.	Chicago, Ill.
Chicago Eye Shield Co.	Chicago, Ill.	Lima Cord Sole & Heel Co., The	Lima, Ohio	Stonelouse Signs, Inc.	Denver, Colo.
Citise Service	New York, N. Y.	Macwhites Co.	Kenosha, Wis.	Strauss Co., Inc.	Pittsburgh, Pa.
Clements Mfg. Co.	Chicago, Ill.	Mathews & Co., Jas. H.	Pittsburgh, Pa.	Surtz Mfg. Co., The	Chicago, Ill.
Clipper Belt Lacer Co.	Grand Rapids, Mich.	McKay Co.	Pittsburgh, Pa.	Trico Fuse Mfg. Co.	Milwaukee, Wis.
Cover, H. E.	South Bend, Ind.	Merkel & Co., Inc.	New York, N. Y.	Trumbull Mfg. Co., The	Warren, Ohio
Davis Emergency Equipment Co., Inc.	New York, N. Y.	Metropolitan Life Insurance Co.	New York, N. Y.	Union Switch & Signal Co.	Swissvale, Pa.
Dayton Safety Ladder Co., The	Cincinnati, Ohio	Mine Safety Appliances Co.	Pittsburgh, Pa.	West Disinfecting Co.	Long Island, N. Y.
Dracco Corp.	Cleveland, Ohio	National Safety Council, Inc.	Chicago, Ill.	Westinghouse Electric & Mfg. Co.	East Pittsburgh, Pa.
Hudley Lock Corp.	Chicago, Ill.	Never Slip Safety Clamp Co.	New York, N. Y.	Williams & Co., J. H.	Buffalo, N. Y.
Ellenod Safety Appliance Co.	Ellwood City, Pa.	Pangborn Corp.	Hagerstown, Md.	Wilson Products, Inc.	Reading, Pa.
Elliott Service Co.	New York, N. Y.	Patent Scaffolding Co., The	Chicago, Ill.		
Fairway Laboratories, Inc.	Belleville, Ill.	Pittsburgh Plate Glass Co.	Pittsburgh, Pa.		
General Abrasive Co.	Niagara Falls, N. Y.				

## INDUSTRIAL SAFETY MARKET

As a service to our readers, we endeavor to maintain a complete list of the source of supply of all types of safety and allied equipment.

If you do not find what you want in the advertising pages, send in the coupon below, and we will have forwarded to you without charge, or obligation, detailed information and catalogs on material to meet your requirements.

National Safety News  
20 North Wacker Drive, Chicago

Please have forwarded to me from various manufacturers, without charge, prices, catalogs, etc., on the following material:  
Specifications: (Be specific as to size, capacity, quantity, etc., when prices are wanted.)

.....  
.....  
.....

Company .....

Address .....

Your Name .....

# THE SAFETY LIBRARY

By MARY M. WELLS  LIBRARIAN, N. S. C.

## BOOKS AND PAMPHLETS

### Accidents and Diseases

"Discussion of Industrial Accidents and Diseases at the 1934 Convention of the International Association of Industrial Accident Boards and Commissions." Published by U. S. Department of Labor, Division of Labor Standards, Bulletin No. 2. For sale by the Superintendent of Documents, Washington, D. C. Price 20c. (282 Page Pamphlet).

### Commercial Vehicles

"Commercial Vehicle Accident Rates for Year Ending June 30, 1935 and Comparisons With Earlier Periods." Published by National Safety Council, Inc., 20 N. Wacker Drive, Chicago, 1935. Price 20c. (16 Page Pamphlet)

This pamphlet gives the accident rates for the commercial vehicles of members of the National Safety Council or affiliated community safety councils.

### Paper Industry

"Paper Manufacture." Published by Retail Credit Co., Atlanta, Ga., 1935. (12 Page Pamphlet). (Industry Report)

A description of paper factory processes and potential health hazards.

### Silicosis

"Review of the Pneumonokonioses (Silicosis) Literature and Laws of 1934," by Davis, G. G. and others. Published by the Chicago Medical Press, 302 S. Canal St., Chicago, 1935. Price \$7.50. (490 Page Book).

In this book (Book II) the articles, papers, comments and discussions appearing in the United States and foreign countries in 1934, upon the subject of the dangers of dust and dust diseases are offered by the editors in abstract form. It includes a digest of statutes, and of legal cases pertaining to occupational disease laws in the United States, supplementary to and bringing up to date the first volume by the editors: "Bibliography and Laws, 1933."

### Spray Painting

"Regulations of the National Board of Fire Underwriters for Paint Spraying and Spray Booths as Recommended by the National Fire Protection Association. Effective September 30, 1935."

Published by National Board of Fire Underwriters, 85 John St., New York City. Free. (13 Page Pamphlet).

These regulations cover standard safeguards for average conditions, and special safeguards for large scale operations.

## PERIODICALS

### Commercial Vehicles

"Selecting and Training Fleet Drivers," by Rose, D. C. (Armored Service Corporation). In *Fleet Owner*, October, 1935, p. 24-25-73.

Selecting drivers for armored cars is quite different from selecting drivers for trucks in ordinary service. Mr. Rose says that in the former service one cannot afford to make mistakes in judging either character or driving ability.

### Hydrogen Fluoride

"The Effects of the Inhalation of Hydrogen Fluoride," by Machle, W. and others. Part II: Response Following Exposure to Law Concentration; III:

Fluorine Storage Following Exposure to Sublethal Concentrations. In *Journal of Industrial Hygiene*, September, 1935, p. 223-240. (Part I was published in March, 1934, issue).

Results prove that hydrogen fluoride is a harmful agent not only as a pulmonary irritant but also as a volatile poison.

### Traffic

"Accidents Can Be Reduced," by Green, P. L. The Institute of Traffic Engineers asked "How?" and ten recognized experts answered. In *American City*, October, 1935, p. 71-77.

While there was complete unanimity of opinion upon only one factor, yet the replies received grouped themselves readily in such broad headings as Enforcement, Engineering, Education, Accident Records, Uniform Ordinances, etc. with emphasis upon the various aspects of enforcement, engineering and education.

## Asked and Answered

### CLAY DUST

QUESTION: In the article "No Half Way Measures in Dust Control," which appeared in the September NATIONAL SAFETY NEWS, there appeared the statement that clay dust is inert, but that here have been claims for disability from workers exposed to it.

In our mills fine, dry clay is used in the manufacture of paper. The method of handling the clay from the freight cars to the bins and from the bins to the mixing tanks varies in the different mills. It ranges from pneumatic conveyors and bucket conveyors to shovels and wheelbarrows. Regardless of the methods used the men work in very dusty conditions. It has been the rule for men to wear respirators when doing this work, although on hot summer days they object to them.

We are interested in determining whether breathing the clay dust over a period of time is injurious and whether we should establish an iron clad rule that the workmen must wear respirators.

Free silica is not present in clay although it does contain silica oxide. The chemical formula for clay is  $Al_2O_3(2) SiO_2(2) H_2O$ .

ANSWER: I have again read very carefully the article by Arthur S. Johnson on "No Half Way Measures in Dust Control." He says, "The result of work by some investigators which has been published recently indicates clay, talc, emery and carborundum dusts to be inert. In some animal experimentation these dusts did not produce fibrosis. Contrarily, there have been claims for disability from workers who alleged that the exposure to these dusts caused their ailments. Experts state that these dusts generally do not produce disabling lung pathology, yet we are faced with the facts of claims prosecuted successfully."

I am enclosing for your review a copy of our Health Practices Pamphlet No. 4, "Dust." On page 2 under the paragraph captioned "Classifications of Dusts," Item II, "Non-poisonous," you will find orthosilicates clay.

Whether dusts are necessarily harmful or not, it is desirable to eliminate them. The inhalation of non-poisonous dust is frequently irritating to the respiratory tract and extremely annoying, necessarily impairing general efficiency.

I have checked the works of such industrial health authorities as Drs. Kober, Hayhurst and Hamilton, and fail to find any comment on the hazards of clay dust. They do, of course, advise the elimination of all dusts insofar as is practicable and possible.

Your practice of having men exposed to these dusts wear respirators is, in our opinion, a desirable one.

NATIONAL SAFETY NEWS

# PULMOSAN

*Headquarters for all types of*

# RESPIRATORS

## M-15 DUST RESPIRATOR

*Featuring new filter pouch that requires no changing—and gives much easier breathing.*

The M-15 Dust Respirator gives highly efficient protection against Type "A" dusts, which are quartz, asbestos, iron ores, cement, limestone, gypsum, coal, coke, charcoal, wood, cellulose, flour and aluminum.

Has all-aluminum body, patented rubber face cushion, all-rubber headbands, flutter exhaust valve and many valuable features. Light weight, comfortable, easy breathing. Reasonably priced. Order an M-15 for trial. Full details on request.

APPROVED  
BY THE  
U. S. BUREAU  
OF MINES

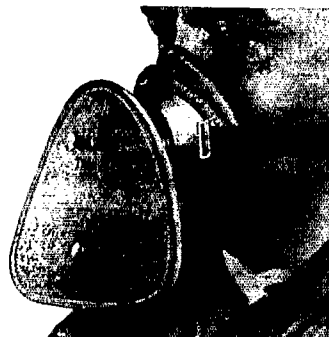

### "M" Series DUST RESPIRATORS

Made in five models. Each gives excellent protection against fine dusts. Have many features found in M-15 model, but use felt filter discs. Light weight, comfortable, easy breathing. A favorite model in many plants. Write for further information.



### For PAINT SPRAY FUMES—GASES and SMOKE

An extensive line of specially designed respirators to meet every breathing hazard. Chemical Cartridge, Paper Cartridge, Sponge Type, Canister and Airline models. With goggles attached, if desired. No. R-150 Chem. Cartridge type shown, for paint spray, organic and acid fumes.

### "CONGRESS ECHOES"

*It was great to renew old acquaintanceship with so many friends at Louisville. We want to thank all for their interest and patronage at our booth.*

Bill & Fred Wahlert.

● Write for your copy!

### NEW PULMOSAN CATALOG

A catalog—reference book—and text book, rolled into one. Use your firm letterhead.

### EVERYTHING for Industrial Safety

If it's for Safety, Pulmosan has it! In addition to more than 30 types of respirators, the line includes Helmets, Hoods, Masks, Goggles, Safety Clothing, Fire-fighting Equipment, Machine Guards, Ladders, Ladder Shoes, etc. Full details on all items is contained in our big, new catalog. Write for it!

## PULMOSAN SAFETY EQUIPMENT CORP.

Member: Industrial Safety Equip. Ass'n.  
176 Johnson St., Brooklyn, N. Y.

Michigan Distr.: THE BOYER-CAMPBELL CO., Detroit  
Lake Superior Dist. Distr.: W. P. & R. S. MARS, Duluth, Minn.

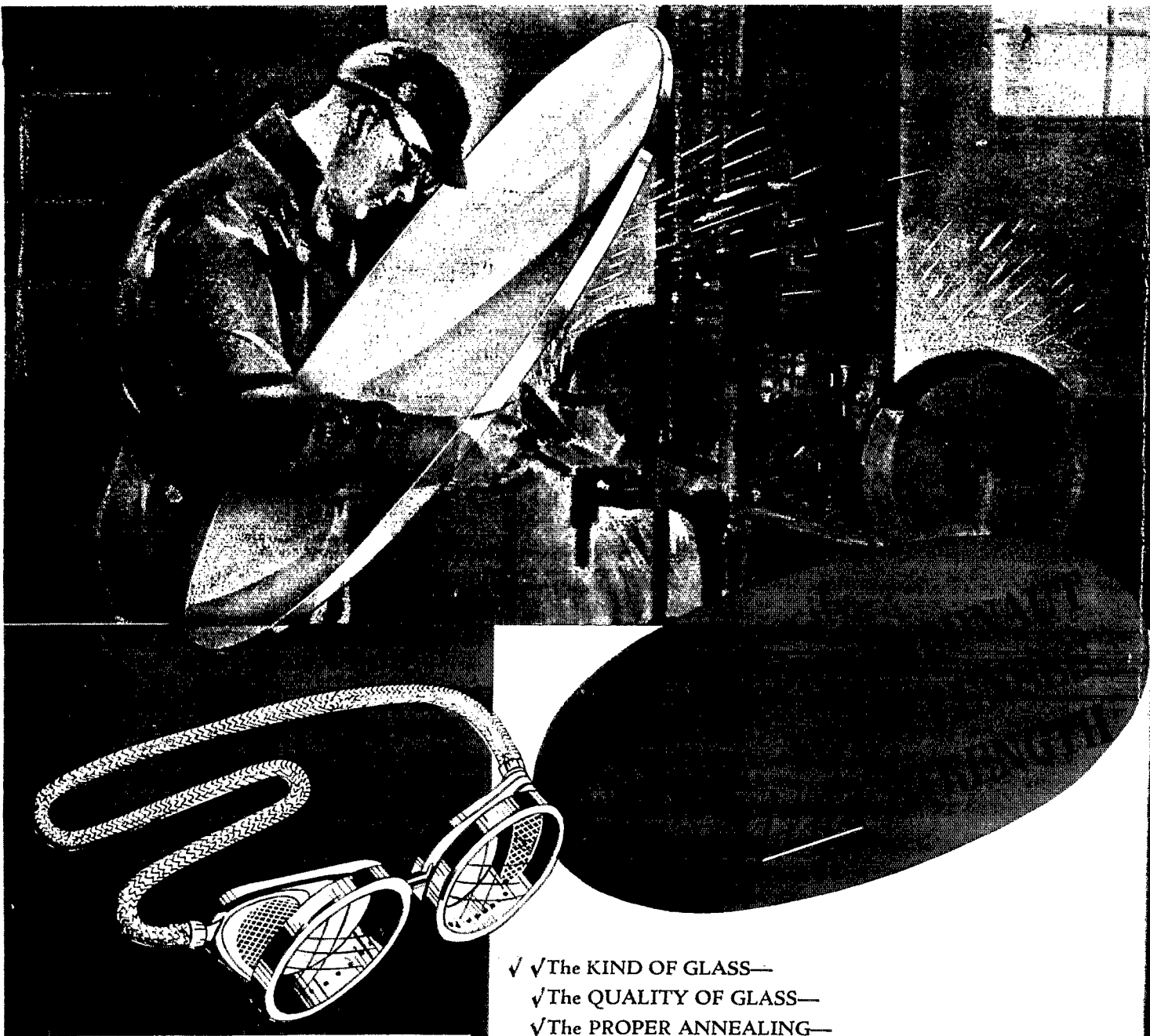

## NEW GENERAL Catalog No. 10

NOW AVAILABLE

This catalog not only illustrates our full line of Goggles, Spectacles, Gloves, Sleevelets, Aprons, Leggings, Helmets, suits and many other items of safety equipment, but is a book of valuable information on Accident Prevention Equipment that is highly desired by both Safety Engineer and Buyer of Safety Equipment.

SEND FOR YOUR COPY NOW!

**SAFETY**  
PREVENTION  
EQUIPMENT  
**SERVICE**

✓ ✓ The KIND OF GLASS—

✓ The QUALITY OF GLASS—

✓ The PROPER ANNEALING—

are all important factors in the production of lenses for industrial Goggles, but in the making of a Safety lens, the

✓ ✓ CURVED FORM

is of vast importance because it adds a vital factor of safety aside from the physical property of the glass. Super-Drednaut Curved or Toric form lenses not only resist breakage to a greater degree than flat lenses, but the curve prevents the broken glass from being driven into the eye, should the lens be broken under a most severe blow.

Only Curved lenses CAN provide this ADDED factor of Safety.

Super-Drednaut Curved Lenses provide the added protection to which your workmen are entitled—and, they cost Goggle purchasers but a few cents more than ordinary lens.

Send for a pair of Super-Drednaut Goggles today—they are the LAST WORD in Goggle construction.