

Message

From: SAE International [Editors@sae.org]
Sent: 8/6/2018 1:30:00 PM
To: Wehrum, Bill [/o=ExchangeLabs/ou=Exchange Administrative Group (FYDIBOHF23SPDLT)/cn=Recipients/cn=33d96ae800cf43a3911d94a7130b6c41-Wehrum, Wil]
Subject: SAE Vehicle Engineering Technology eNewsletter August 2018

 [VIEW ONLINE](#)

[SUBSCRIBE](#)



[FORWARD TO A FRIEND](#)

Panasonic

View, Bookmark and Share Datasheets



[DOWNLOAD NOW](#)



VEHICLE ENGINEERING
TECHNOLOGY ENEWSLETTER

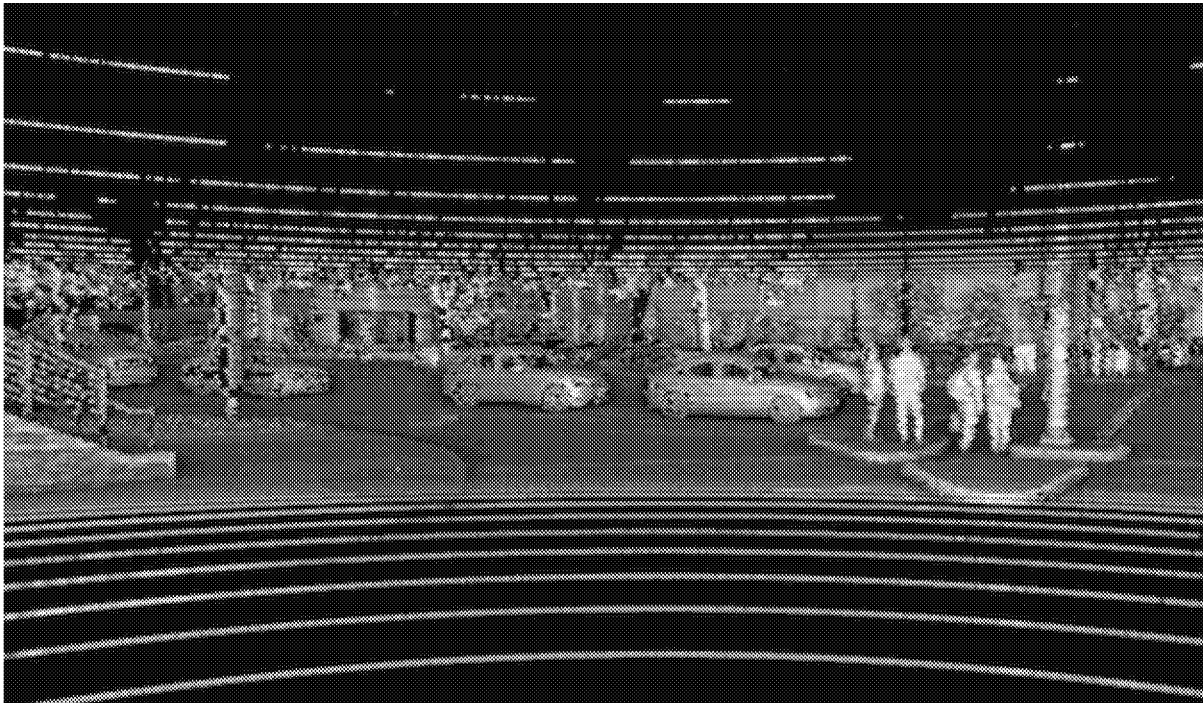

LiDAR: New "eyes" for vehicle autonomy

Steadily evolving lidar sensor technology will offer significant leaps forward in autonomous capability—once cost is reduced.

[Read More >](#)

Sponsored Content

WaveFarer for Auto Radar Simulation

This short video introduces WaveFarer, a targeted software solution that simulates raw radar returns for drive test scenarios.

WaveFarer enables Tier 1 suppliers to virtually test and refine results earlier in the design process, improving installed sensor performance.

[Learn More >](#)



Toyota launches second-gen fuel-cell Class 8

With a longer-range and more-refined fuel cell-powered heavy-duty truck, Toyota aims to eventually eliminate emissions from trucks serving increasingly congested California ports.

[Read More »](#)



Sponsored Content

Robust Laser, Optical, and Magnetic Encoders

Renishaw provides high quality optical, magnetic and laser encoders that provide higher accuracy, easier installation, and superior reliability. Discover our range of encoder systems and learn how they can fit into your application needs.

[Learn More »](#)

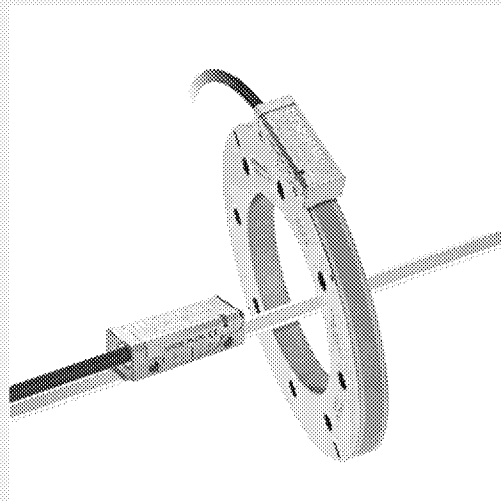

GE Aviation, Teradata partner on data analytics, edge connectivity for airlines

GE Aviation and Teradata are expanding their partnership to provide airlines with a framework that combines Teradata's high-performance cloud analytics with GE Aviation's edge-connectivity services.

[Read More »](#)



Sponsored Content

Fast, Sensitive, Reliable Leak Detection

The Pfeiffer Vacuum ASM 340 performs helium or hydrogen leak detection in vacuum and sniffer modes. It detects leaks to 5×10^{-12} mbar l/s in vacuum mode and 5×10^{-9} mbar l/s in sniffing mode. This durable, high performance leak detector offers I/O interface, SD memory card and wireless remote operation up to 100 meters.

[Learn More »](#)



E-Axles speed electrification

The e-axle business is booming, proving a practical 'bridge' between today's legacy auto architectures and the fully-electrified future.

[Read More »](#)

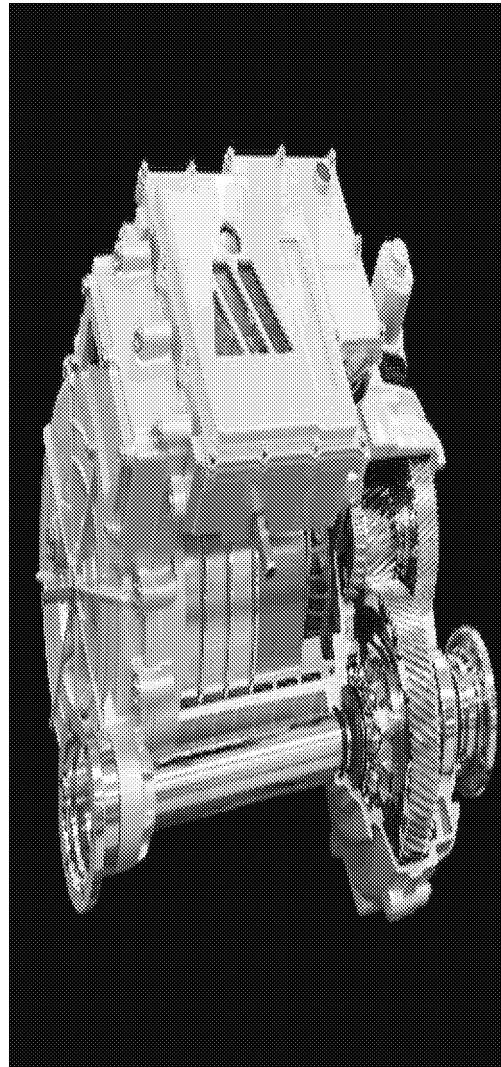

Sponsored Content

KATO LockOne – Superior Locking for Unified & Metric Sizes

KATO LockOne® is a lightweight, FOD Free, positive locking device designed to prevent a standard nut from loosening free under vibration. LockOne is reusable, does not degrade and can be easily substituted into existing designs. KATO's LockOne is fast, easy to install, and tested in accordance with NAS3350. Save time and money with LockOne Today!

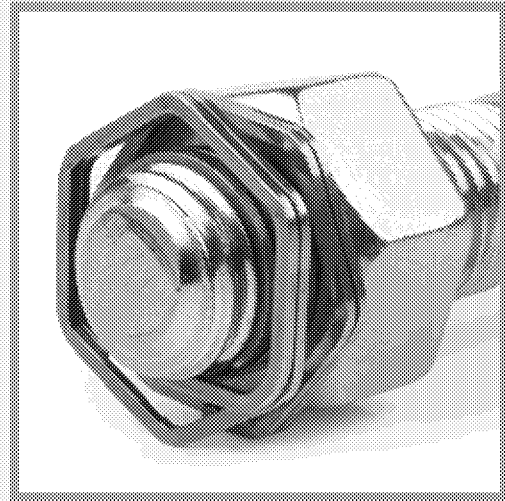

[Learn More »](#)

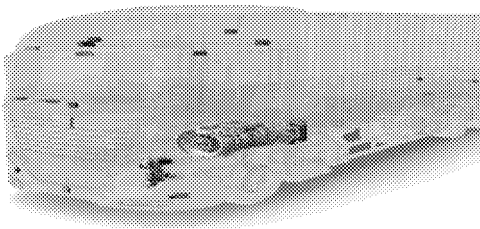

ADAS features expand role, V2V looms

Truck owners and commercial-vehicle suppliers are ramping up their safety efforts, making more advanced driver-assistance systems (ADAS) standard while looking at the potential benefits of vehicle-to-vehicle (V2V) communications.

[Read More »](#)



NASA partners with ONERA on low-boom supersonic flight

The research hinges on developing an accurate method of determining where the sound waves of sonic booms will impact the ground as supersonic aircraft fly overhead.

[Read More »](#)

WEBCAST ALERT

WEBCAST ALERT



Streamlining Vehicle Development with Wheel Force Transducers

Wednesday, August 29, 2018

The newest generation of wheel force transducers has made it possible to obtain high-quality data in an efficient manner. In this webinar engineers from MTS will discuss an overview of the SWIFT Evo design, the importance of certain design specifications, and an outline of the RLDA data captured during testing and how to use it.

[Register Now »](#)

Smart Cities and the V2X Factor

Thursday, August 16, 2018

This 60-minute technical webinar from the editors of SAE International examines the latest in vehicle-to-infrastructure (V2I) and vehicle to everything (V2X) communication. Topics include safety/mobility applications, data collection, security and vehicle and infrastructure interoperability.

[Register Now »](#)

SPONSORED LINKS

PENDANT ARMOR® – Stay Protected. Stay Productive

Pendant Armor® is the first shock absorbing, chemical resistant bumper designed to protect teach pendants from drops, spills, and extreme conditions.

[View Specs & Get A Quote »](#)

Koolmat Hi-Tech Heat Insulation

Koolmat, a silicone/fiberglass, thin, 1200°F composite. Abrasion, mildew resistant, won't crack, peel, dry out, curl or shrink in years. No air or liquid will pass through it.

[Learn More »](#)

SAE International • 400 Commonwealth Drive • Warrendale, PA 15096-0001 USA

Using the SAE INTERNATIONAL's email products, you agree that inquiry information may be sent to

only those companies you visit or request more information on. SAE believes you will benefit from this information. If you would like to stop receiving this product, [click here](#) to maintain your preferences.

For details on our commitment to your privacy, [click here](#).

For customer service, email us at eresponse@techbriefs.com or customerservice@techbriefs.com.

Copyright © 2018 SAE International. All rights reserved.